



DL47B3A

2.5 Gbps 1550 nm Direct Modulation DFB Laser Module

Features

- High-performance MQW DFB Laser
- Built-in TEC, Thermistor and Monitor PD
- 25Ω Input Impedance Matching
- Built-in Optical Isolator
- Hermetically Sealed 14-pin Butterfly Package
- High Output Power of 2 mW and 10 mW
- Long-term Wavelength Stability and High Reliability
- Wide operating case temperature range of -20 °C to 75 °C
- ITU Wavelengths Available from 1528.77 nm to 1610.06 nm
- Meet Telcordia Technologies GR-468-CORE requirements



Applications

SONET/SDH and Metro DWDM systems compatible up to OC-48/STM-16 for extended reach (100 km) and very long reach (170 km) applications.

Product Code

Product Code	Optical Output Power	Dispersion Performance
DL47B3A-B	2 mW	1800 ps/nm (100 km)
DL47B3A-D	2 mW	3000 ps/nm (170 km)
DL47B3C-B	10 mW	1800 ps/nm (100 km)

Description

The DL47B3 direct modulation distributed feedback (DFB) laser modules are designed to be used in various OC-48/STM-16 systems applications. The high performance multiple quantum well (MQW) laser is packaged in a hermetically sealed butterfly package with a thermoelectric cooler (TEC), a thermistor and a monitor photodiode. Selected wavelengths specified to the ITU-T channel are available.

Pin Information

DL47B3A			
Pin	Definition	Pin	Definition
1	Thermistor	8	Case Ground
2	Thermistor	9	Case Ground
3	Laser Cathode (-)	10	NC ⁽¹⁾
4	Monitor PD Anode (-)	11	Laser Anode (+)
5	Monitor PD Cathode (+)	12	RF Input Cathode (-)
6	TEC (+)	13	Laser Anode (+)
7	TEC (-)	14	NC ⁽¹⁾

⁽¹⁾ Not Connected

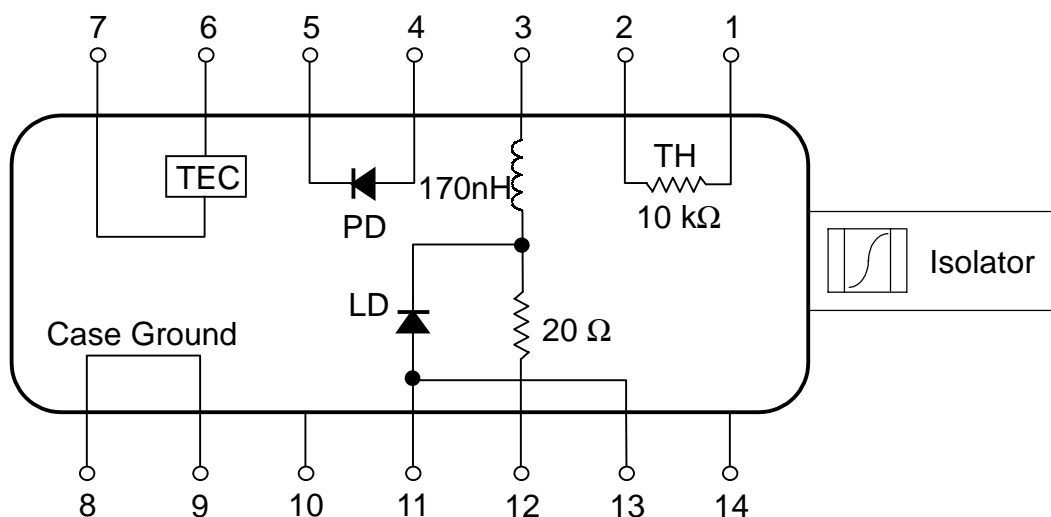

Module Performance Characteristics

DL47B3A-B/D (2mW) condition : $T_{op}=25^{\circ}\text{C}$, BOL, unless otherwise specified

Parameter	Symbol	Test Conditions	Min	Typ	Max	Unit
Electrical characteristics						
Threshold current	I_{TH}	CW		11	25	mA
Operating current	I_{OP}	CW, $P_F=2\text{ mW}$		31	65	mA
Operating voltage	V_{OP}	CW, $P_F=2\text{ mW}$		1.05	1.8	V
Input impedance	R_s			25		Ω
Monitor dark current	I_D	$V_{RPD}=5\text{ V}$			100	nA
Monitor reverse bias voltage	V_{BM}		3	5	10	V
Monitor current	I_M	CW, $P_F=2\text{ mW}$, $V_{BMPD}=5\text{ V}$	0.1	0.5	1	mA
TEC current	I_C	$T_L=25^{\circ}\text{C}$, $T_C=75^{\circ}\text{C}$		700	1000	mA
TEC voltage	V_C	$T_L=25^{\circ}\text{C}$, $T_C=75^{\circ}\text{C}$		1.7	2.5	V
TEC capacity	ΔT	$T_C=75^{\circ}\text{C}$	50			$^{\circ}\text{C}$
TEC resistance	R_C	$T_L=25^{\circ}\text{C}$, $T_C=75^{\circ}\text{C}$			3.5	Ω
Cooler power	P_C	$T_L=25^{\circ}\text{C}$, $T_C=75^{\circ}\text{C}$		1.0	2.5	W
Thermistor resistance	R_{TR}	$T_L=25^{\circ}\text{C}$	9.5	10	10.5	k Ω
Thermistor β constant	β	$T_L=25^{\circ}\text{C}$ to 85°C	3917	3969	3981	K
Optical characteristics						
Slope efficiency	η	CW, $P_F=2\text{ mW}$	0.06	0.1		mW/mA
Optical output power	P_F	CW	2			mW
Threshold power	P_{TH}	$I_F=I_{TH}$, CW			100	μW
Spectral width						
Full width at -3 dB	$\Delta\lambda$	(1)		0.11	0.2	nm
Full width at -20 dB				0.30	0.5	nm
Side mode suppression ratio	SMSR	(1)	30	37		dB
Relative intensity noise	RIN	CW, $P_F=2\text{ mW}$ 0.5~3 GHz			-145	dB/Hz
Peak wavelength	λ_c		1528		1610	nm
Wavelength stability with case temperature	$\Delta\lambda_c/\Delta T_C$	$T_C=-20\sim 75^{\circ}\text{C}$	-1		+1	pm/ $^{\circ}\text{C}$
Wavelength tuning coefficient	$\Delta\lambda_c/\Delta T_{LD}$	CW		0.09		nm/ $^{\circ}\text{C}$

Laser operating temperature	T_L		20		35	°C
Tracking error	TR	(2)			+10	%
Rise time (10%-90%)	T_R	(1)			150	psec
Fall time (10%-90%)	T_F	(1)			150	psec
Cutoff frequency	F_C	$P_F=2$ mW	3.5			GHz
RF return loss	S_{11}	f=50 MHz~5 GHz	3			dB
Optical isolation	I_{SO}	$T_C=-20$ to 75 °C	25			dB
Dispersion performance						
Dispersion penalty	DP	(1), D=1800 ps/nm, 3000 ps/nm			2	dB

(1) 2.5 Gbps NRZ, 2²³-1 PRBS, $P_{AVE} = 1$ mW, ER = 10dB, BER=10⁻¹⁰

(2) ACC, $[P_F(25^\circ\text{C})-P_F(75^\circ\text{C})]/P_F(25^\circ\text{C})$

DL47B3C-B (10mW) Condition : $T_{op}=25^\circ\text{C}$, BOL, unless otherwise specified

Parameter	Symbol	Test Conditions	Min	Typ	Max	Unit
Electrical characteristics						
Threshold current	I_{TH}	CW		11	25	mA
Operating current	I_{OP}	CW, $P_F=10$ mW		70	90	mA
Operating voltage	V_{OP}	CW, $P_F=10$ mW		1.05	1.8	V
Input impedance	R_S			25		Ω
Monitor dark current	I_D	$V_{RPD}=5$ V			100	nA
Monitor reverse bias voltage	V_{BM}		3	5	10	V
Monitor current	I_M	CW, $P_F=10$ mW, $V_{BMPD}=5$ V	0.1	0.5	1	mA
TEC current	I_C	$T_L=25^\circ\text{C}$, $T_C=75^\circ\text{C}$		700	1000	mA
TEC voltage	V_C	$T_L=25^\circ\text{C}$, $T_C=75^\circ\text{C}$		1.7	2.5	V
TEC capacity	ΔT	$T_C=75^\circ\text{C}$	50			°C
TEC resistance	R_C	$T_L=25^\circ\text{C}$, $T_C=75^\circ\text{C}$			3.5	Ω
Cooler power	P_C	$T_L=25^\circ\text{C}$, $T_C=75^\circ\text{C}$		1.0	2.5	W
Thermistor resistance	R_{TR}	$T_L=25^\circ\text{C}$	9.5	10	10.5	k Ω
Thermistor β constant	β	$T_L=25^\circ\text{C}$ to 85 °C	3917	3969	3981	K
Optical characteristics						

Slope efficiency	η	CW, $P_F=10$ mW	0.13	0.17		mW/m A
Optical output power	P_F	CW	10			mW
Threshold power	P_{TH}	$I_F=I_{TH}$, CW			150	μ W
Spectral width						
Full width at -3 dB	$\Delta\lambda$	(1)		0.11	0.2	nm
Full width at -20 dB				0.30	0.5	nm
Side mode suppression ratio	SMSR	(1)	30	37		dB
Relative intensity noise	RIN	CW, $P_F=10$ mW, 0.5~3 GHz			-145	dB/Hz
Peak wavelength	λ_c	(1)	1528		1610	nm
Wavelength stability with case temperature	$\Delta\lambda_c/\Delta T_c$	$T_c=-20\sim 75$ °C	-1		+1	pm/°C
Wavelength tuning coefficient	$\Delta\lambda_c/\Delta T_{LD}$	CW		0.09		nm/°C
Laser operating temperature	T_L		20		35	°C
Tracking error	TR	(2)			+10	%
Rise time (10%-90%)	T_R	(1)			150	psec
Fall time (10%-90%)	T_F	(1)			150	psec
Cutoff frequency	F_C	$P_F=10$ mW	3.5			GHz
RF return loss	S_{11}	f=50 MHz~5 GHz	3			dB
Optical isolation	I_{SO}	$T_c=-20$ to 75 °C	25			dB
Dispersion performance						
Dispersion penalty	DP	(1), D=1800 ps/nm			2	dB

(1) 2.5 Gbps NRZ, $2^{23}-1$ PRBS, $P_{AVE} = 5$ mW, ER = 10dB, BER= 10^{-10}

(2) ACC, $[P_F(25^\circ\text{C})-P_F(75^\circ\text{C})]/P_F(25^\circ\text{C})$

Absolute Maximum Ratings

These are absolute maximum ratings only. Higher stress than these ratings may adversely affect device reliability or cause permanent damage to the device.

Parameter	Symbol	Min	Max	Unit
Optical output power (CW) DL47B3A DL47B3C	P_F		5 15	mW
Laser forward current (DC)	I_F		150	mA
Laser reverse voltage	V_R		2	V
Photodiode reverse voltage	V_{RMPD}		10	V
Photodiode forward current	I_{FMPD}		2	mA
Lead solder temperature	T_{SOLD}		260	°C
Lead solder time	t_{SOLD}		10	sec
Storage temperature	T_{STG}	-40	85	°C
Operating case temperature	T_C	-20	75	°C

Outline Diagram

Dimensions are in millimeters (inches).

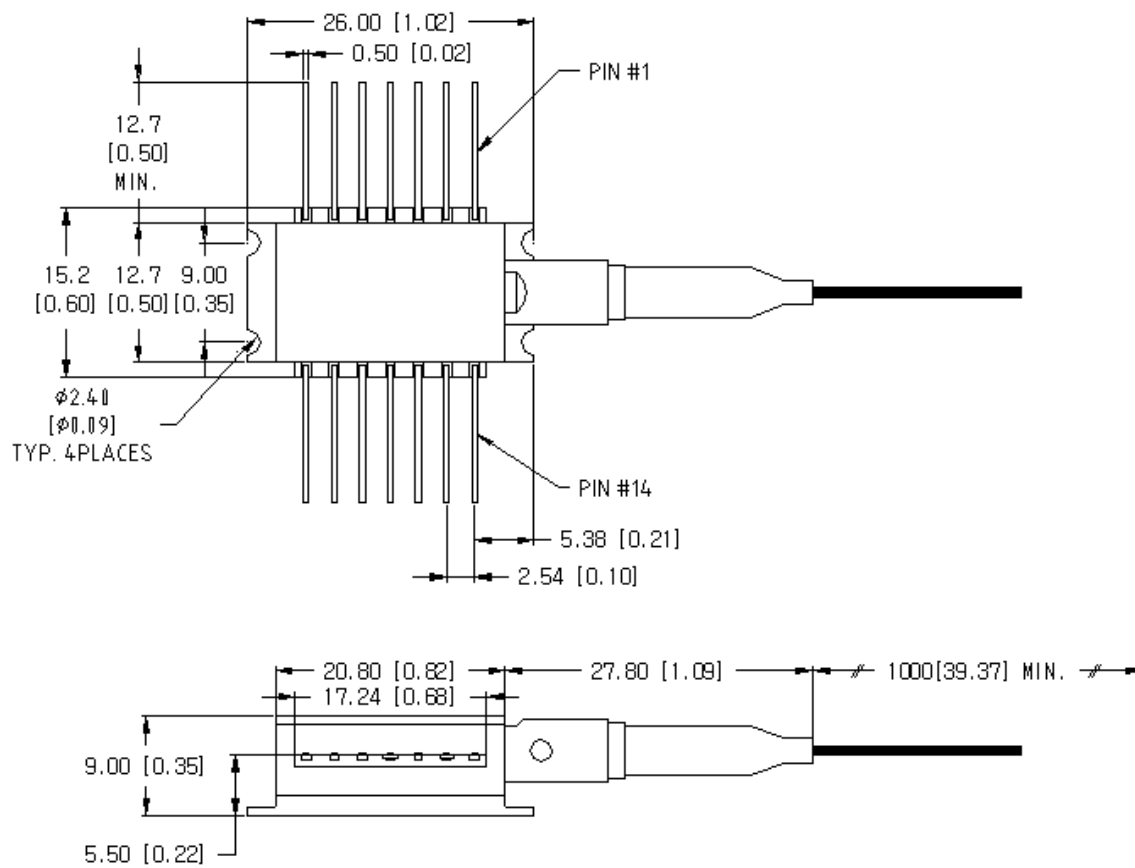

Characteristics Performance

1. Small Signal Modulation Response

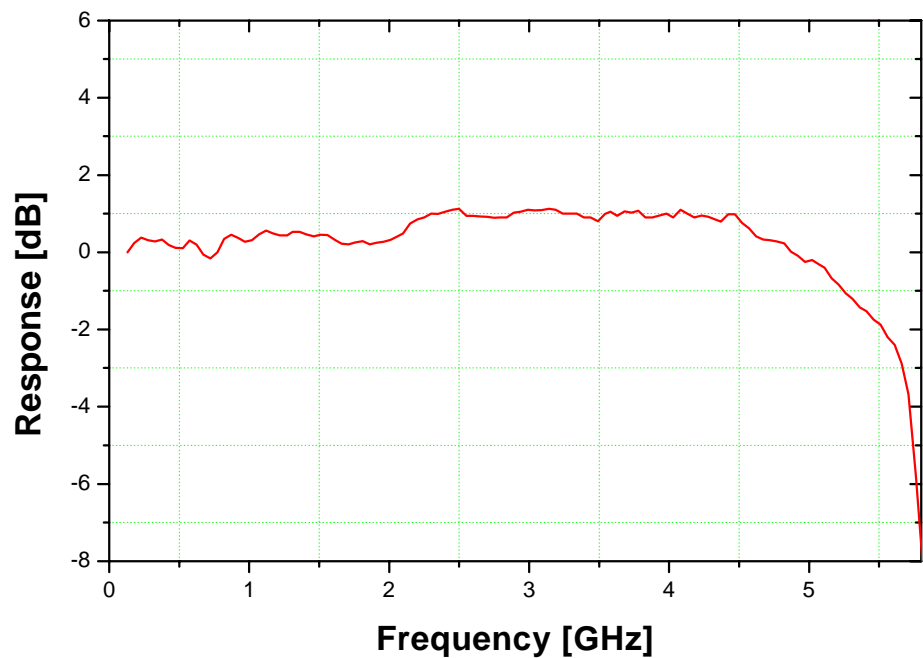

2. Spectrum

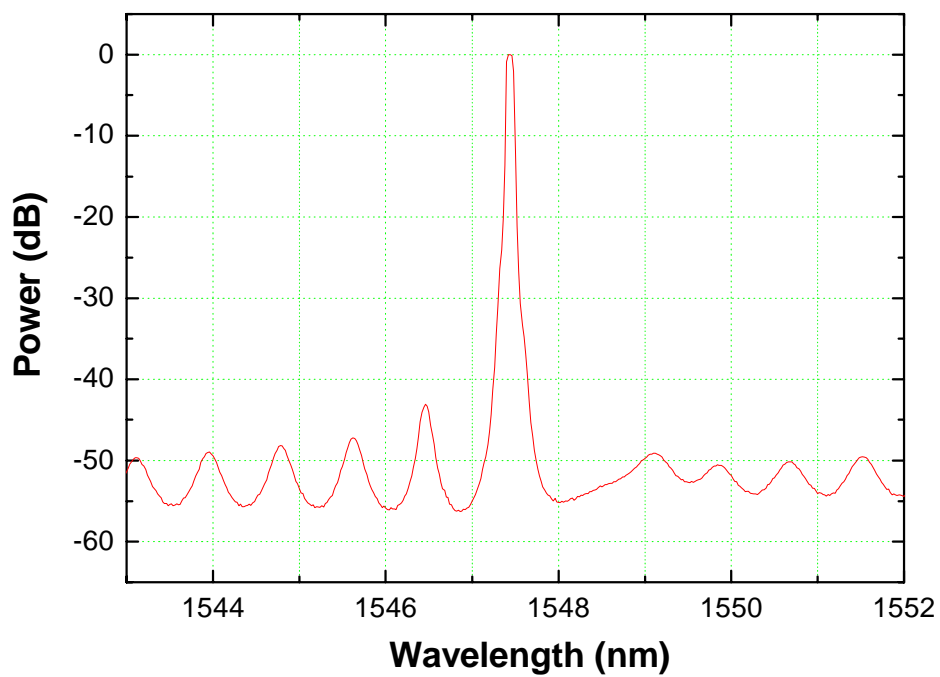

3. Back-to-back and 100 km Transmitted Eye Diagram at 2.5Gbps

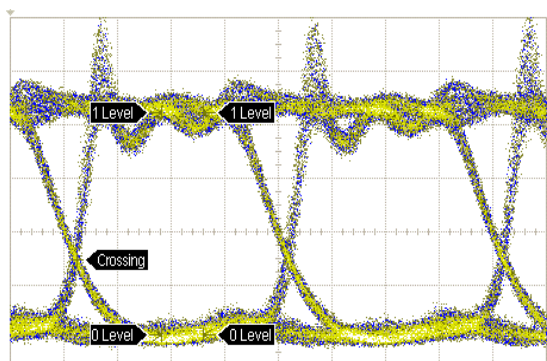

Back to Back

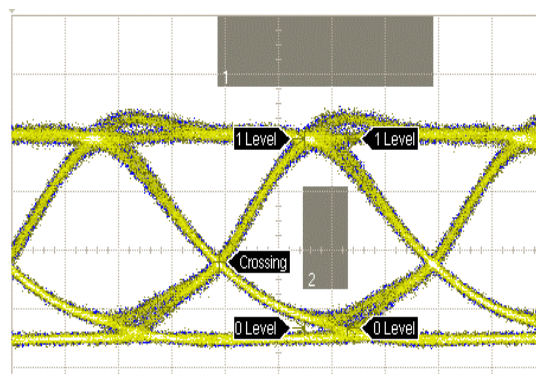

After 100km Transmission

4. BER vs. Optical Power

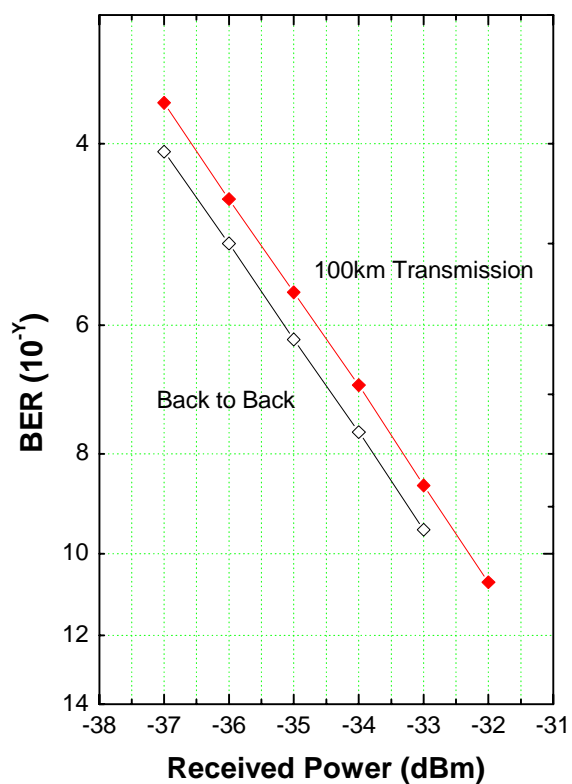

DL47B3A-B (100km)

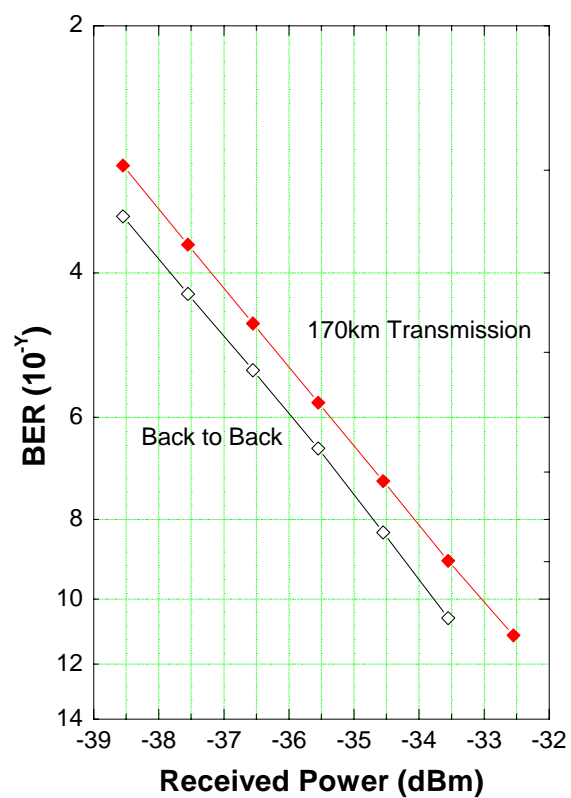

DL47B3A-D (170km)

Ordering Information

Laser Selection Code :

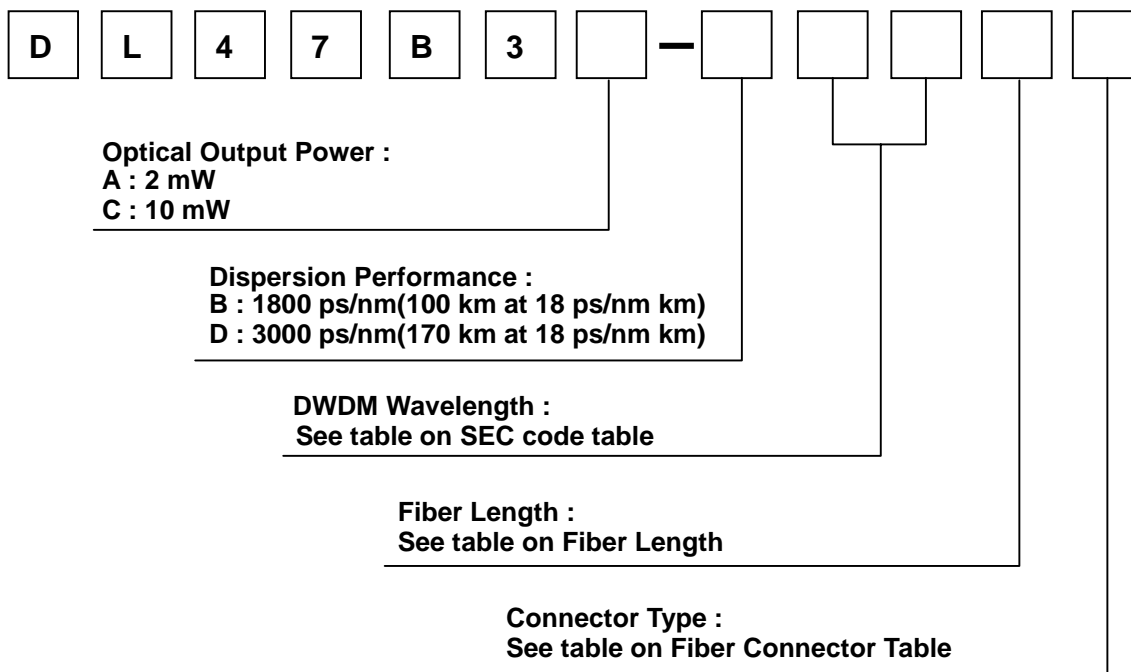

Fiber Length

Code	Fiber Length
A	0.5 m
B	1.0 m
C	1.5 m
D	2.0 m
E	2.5 m

Fiber Connector Type

Code	Connector Type
1	FC/PC
2	FC/APC
3	ST/PC
4	SC/PC
5	Biconic
6	No connector

SEC code for DWDM Wavelength

Center Wavelength(nm)	DWDM Wavelength Code	ITU Frequency(THz)	Wavelength Tolerance
1528.77	61	196.1	±0.4nm
1529.55	60	196.0	±0.4nm
1530.33	59	195.9	±0.4nm
1531.12	58	195.8	±0.4nm
1531.90	57	195.7	±0.4nm
1532.68	56	195.6	±0.4nm
1533.47	55	195.5	±0.4nm
1534.25	54	195.4	±0.4nm
1535.04	53	195.3	±0.4nm
1535.82	52	195.2	±0.4nm
1536.61	51	195.1	±0.4nm
1537.40	50	195.0	±0.4nm
1538.19	49	194.9	±0.4nm
1538.98	48	194.8	±0.4nm
1539.77	47	194.7	±0.4nm
1540.56	46	194.6	±0.4nm
1541.35	45	194.5	±0.4nm
1542.14	44	194.4	±0.4nm
1542.94	43	194.3	±0.4nm
1543.73	42	194.2	±0.4nm
1544.53	41	194.1	±0.4nm
1545.32	40	194.0	±0.4nm
1546.12	39	193.9	±0.4nm
1546.92	38	193.8	±0.4nm
1547.72	37	193.7	±0.4nm
1548.51	36	193.6	±0.4nm
1549.32	35	193.5	±0.4nm
1550.12	34	193.4	±0.4nm
1550.92	33	193.3	±0.4nm
1551.72	32	193.2	±0.4nm
1552.52	31	193.1	±0.4nm
1553.33	30	193.0	±0.4nm
1554.13	29	192.9	±0.4nm
1554.94	28	192.8	±0.4nm
1555.75	27	192.7	±0.4nm
1556.55	26	192.6	±0.4nm
1557.36	25	192.5	±0.4nm
1558.17	24	192.4	±0.4nm
1558.98	23	192.3	±0.4nm
1559.79	22	192.2	±0.4nm
1560.61	21	192.1	±0.4nm
1561.42	20	192.0	±0.4nm
1562.23	19	191.9	±0.4nm
1563.05	18	191.8	±0.4nm
1563.86	17	191.7	±0.4nm
1564.68	16	191.6	±0.4nm
1565.50	15	191.5	±0.4nm
1566.31	14	191.4	±0.4nm
1567.13	13	191.3	±0.4nm
1567.95	12	191.2	±0.4nm
1568.77	11	191.1	±0.4nm
1569.59	10	191.0	±0.4nm
1570.42	09	190.9	±0.4nm
1571.24	08	190.8	±0.4nm
1572.06	07	190.7	±0.4nm
1572.89	06	190.6	±0.4nm
1573.71	05	190.5	±0.4nm

1574.54	04	190.4	±0.4nm
1575.37	03	190.3	±0.4nm
1576.20	02	190.2	±0.4nm
1577.02	01	190.1	±0.4nm
1577.85	00	190.0	±0.4nm
1578.69	99	189.9	±0.4nm
1579.52	98	189.8	±0.4nm
1580.35	97	189.7	±0.4nm
1581.18	96	189.6	±0.4nm
1582.02	95	189.5	±0.4nm
1582.85	94	189.4	±0.4nm
1583.69	93	189.3	±0.4nm
1584.53	92	189.2	±0.4nm
1585.36	91	189.1	±0.4nm
1586.20	90	189.0	±0.4nm
1587.04	89	188.9	±0.4nm
1587.88	88	188.8	±0.4nm
1588.72	87	188.7	±0.4nm
1589.57	86	188.6	±0.4nm
1590.41	85	188.5	±0.4nm
1591.25	84	188.4	±0.4nm
1592.10	83	188.3	±0.4nm
1592.95	82	188.2	±0.4nm
1593.79	81	188.1	±0.4nm
1594.64	80	188.0	±0.4nm
1595.45	79	187.9	±0.4nm
1596.34	78	187.8	±0.4nm
1597.19	77	187.7	±0.4nm
1598.04	76	187.6	±0.4nm
1598.89	75	187.5	±0.4nm
1599.75	74	187.4	±0.4nm
1600.60	73	187.3	±0.4nm
1601.45	72	187.2	±0.4nm
1602.31	71	187.1	±0.4nm
1603.17	70	187.0	±0.4nm
1604.33	69	186.9	±0.4nm
1604.88	68	186.8	±0.4nm
1605.74	67	186.7	±0.4nm
1606.60	66	186.6	±0.4nm
1607.47	65	186.5	±0.4nm
1608.33	64	186.4	±0.4nm
1609.19	63	186.3	±0.4nm
1610.06	62	186.2	±0.4nm

Handling Precaution

Power Sequence

Following the turn-on sequence is required to avoid possible damage to the laser module from power supply switching transients.

1. All ground connections
2. Most negative supply
3. Most positive supply
4. All remaining connections

Reverse the order for the proper turn-off sequence

Electrostatic Discharge

Caution: The device is susceptible to damage as a result of electrostatic discharge

Widely accepted human-body model (resistance=1.5K Ω , Capacitance=100pF) for susceptibility testing and protection-design is employed as a circuit parameter.

Parameter	Value	Unit
Human-body model	>400	V

Laser Safety Information

Class IIIb Laser Product

This product complies with 21 CFR 1040.10. and 1040.11.

8.3/125 μm single-mode fiber pigtail and connector

Wavelength=1550 nm

Maximum power = 40 mW

Label is not affixed to the module because of size constraints but is contained in the shipping carton.

Product is not shipped with power supply

Caution: Use of controls, adjustments, and procedures other than those specified herein may result in hazardous laser radiation exposure

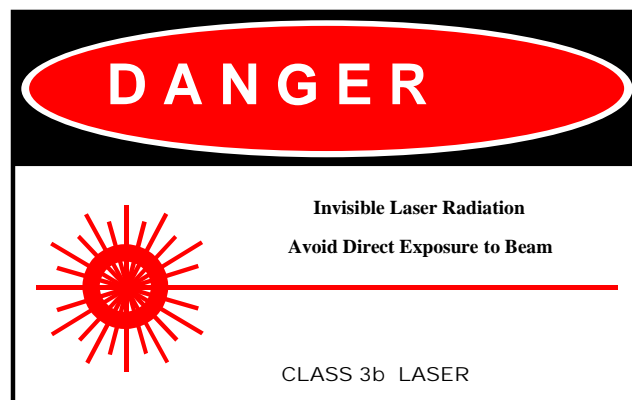

Samsung's DFB Laser is a Class 3b laser and should be treated as a potential eye hazard.

Contact us

Samsung Optoelectronics Division
416 Maetan-3Dong, Paldal-Gu
Suwon, Kyungki - Do
Korea 442-742

Phone: (82) 31-200-8703

Fax: (82) 31-200-8811

E-mail:

optoamer@samsungelectronics.com

optoeuaf@samsungelectronics.com

optoasia@samsungelectronics.com

URL: www.samsungfiberoptics.com

Samsung Electronics Company Limited reserves the right to change products and specifications without notice. Copyright 2001 © Samsung Electronics Co, Ltd. All rights Reserved.