

RS6513

PWM Control 2A Step-Down Converter

RS6513 provides low-ripple power, high efficiency, and excellent transient characteristics. The PWM control circuit is able to vary the duty ratio linearly from 0 up to 100%. This converter also contains an error amplifier circuit as well as a soft-start circuit that prevents overshoot at startup. An enable function, an over current protect function and a short circuit protect function are built inside, and when OCP or SCP happens, the operation frequency will be reduced from 350KHz to 30KHz. Also, an internal compensation block is built in to minimum external component count.

With the addition of an internal P-channel Power MOS, a coil, capacitors, and a diode connected externally, these ICs can function as step-down switching regulators. They serve as ideal power supply units for portable devices when coupled with the SOP-8L mini-package, providing such outstanding features as low current consumption. Since this converter can accommodate an input voltage up to 18V, it is also suitable for the operation via an AC adapter.

Features

- Input voltage: 3.6V to 18V.
- Output voltage: 0.8V to V_{CC} .
- Duty ratio: 0% to 100% PWM control
- Oscillation frequency: 350KHz typ.
- Soft-start, Current limit, Enable function
- Thermal Shutdown function
- Built-in internal SW P-channel MOS
- SOP-8L Pb-Free Package.

Applications

- PC Motherboard
- LCD Monitor
- Graphic Card
- DVD-Video Player
- Telecom Equipment
- ADSL Modem
- Printer and other Peripheral Equipment
- Microprocessor core supply
- Networking power supply

Pin Configurations

<p>(TOP VIEW)</p> <p>FB 8 Vss EN 2 7 Vss OCSET 3 6 Output Vcc 4 5 Output</p>	Pin 1: Feedback pin.	Pin 5: Switch Pin. Connect external inductor/diode here. Minimize trace area at this pin to reduce EMI
	Pin 2: Power-off pin H: Normal operation (Step-down operation) L: Step-down operation stopped (All circuits deactivated)	Pin 6: Switch Pin. Connect external inductor/diode here. Minimize trace area at this pin to reduce EMI
	Pin 3: Add an external resistor to set max output current	Pin 7: GND Pin
	Pin 4: IC power supply pin	Pin 8: GND Pin

Block Diagram

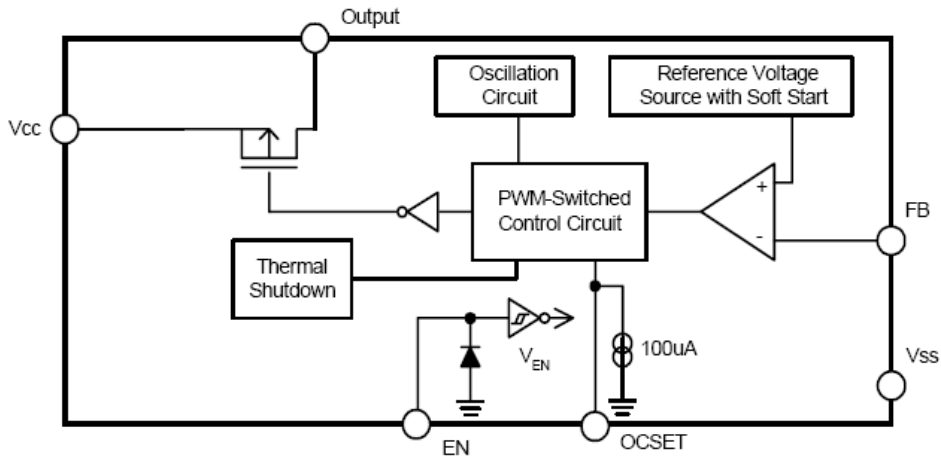

Absolute Maximum Ratings

Symbol	Parameter	Range	Units
V_{CC}	V_{CC} Pin Voltage	$V_{SS}-0.3$ to $V_{SS}+22$	V
V_{FB}	Feedback Pin Voltage	$V_{SS}-0.3$ to V_{CC}	V
V_{EN}	EN Pin Voltage	$V_{SS}-0.3$ to $V_{IN}+0.3$	V
V_{OUTPUT}	Switch Pin Voltage	$V_{SS}-0.3$ to $V_{IN}+0.3$	V
P_D	Power Dissipation	Internally limited	mW
T_{OPR}	Operating Temperature Range	-20 to +125	°C
T_{STG}	Storage Temperature Range	-40 to +150	°C

Electrical Characteristics ($V_{IN} = 12V$, $T_a=25^\circ C$, unless otherwise specified)

Symbol	Parameter	Conditions	Min.	Typ.	Max.	Unit
V_{IN}	Input Voltage	-	3.6	-	18	V
V_{FB}	Feedback Voltage	$I_{OUT}=0.1A$	0.782	0.8	0.818	V
I_{FB}	Feedback Bias Current	$I_{OUT}=0.1A$	-	0.1	0.5	uA
I_{SW}	Switch Current	-	2.5	-	-	A
I_{SSS}	Current Consumption During Power Off	$V_{EN}=0V$	-	10	-	uA
$\Delta V_{OUT}/V_{OUT}$	Line Regulation	$V_{IN}=5V \sim 18V$	-	2	4	%
$\Delta V_{OUT}/V_{OUT}$	Load Regulation	$I_{OUT}=0.1$ to $2A$	-	0.2	0.5	%
F_{OSC}	Oscillation Frequency	Measure waveform at SW pin	300	350	400	KHz
F_{OSC1}	Frequency of Current Limit or Short Circuit Protect	Measure waveform at SW pin	10	-	-	KHz
V_{SH}	EN Pin Input Voltage	Evaluate oscillation at SW pin	2.0	-	-	V
V_{SL}		Evaluate oscillation stop at SW pin	-	-	0.8	
I_{SH}	EN Pin Input Leakage Current	-	-	20	-	uA
I_{SL}		-	-	-10	-	
I_{OCSET}	OCSET Pin Bias Current	-	75	90	105	uA
T_{SS}	Soft-Start Time	-	0.3	2	5	ms
$R_{DS(ON)}$	Internal MOSFET $R_{DS(ON)}$	$V_{IN}=5V, V_{FB}=0V$	-	110	150	mΩ
		$V_{IN}=12V, V_{FB}=0V$	-	70	100	
EFFI	Efficiency	$V_{IN}=12V, V_{OUT}=5V, I_{OUT}=2A$	-	92	-	%
θ_{JA}	Thermal Resistance Junction-to-Ambient	-	-	65	-	°C/W

Typical Application Circuit

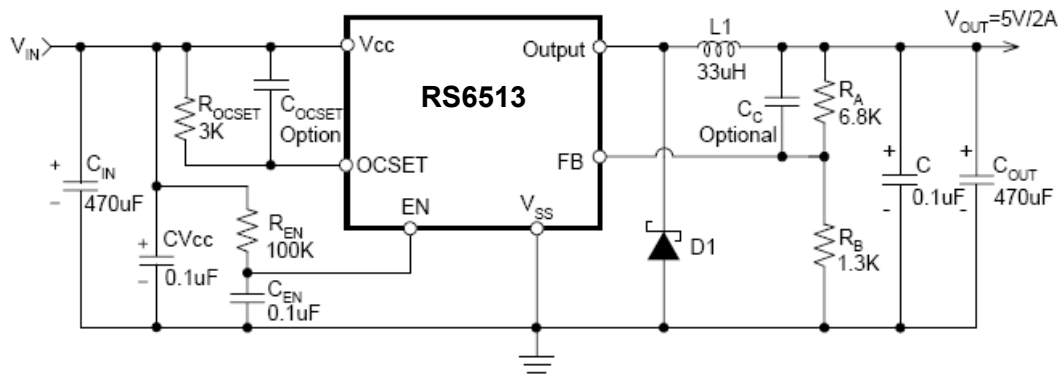

Note: $V_{OUT} = V_{FB} \times (1 + R_A/R_B)$
 $R_B = 0.7K \sim 5K \text{ ohm}$

$V_{IN} = 12V, I_{MAX} = 2A$			
V_{OUT}	2.5V	3.3V	5V
L1 Value	22uH	27uH	33uH

Typical Performance Characteristics

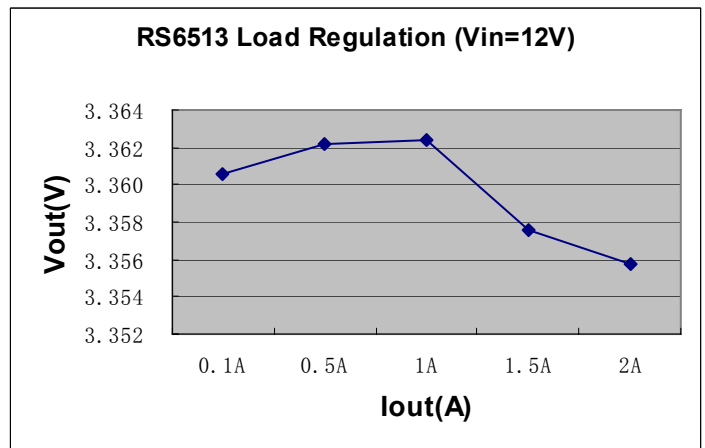
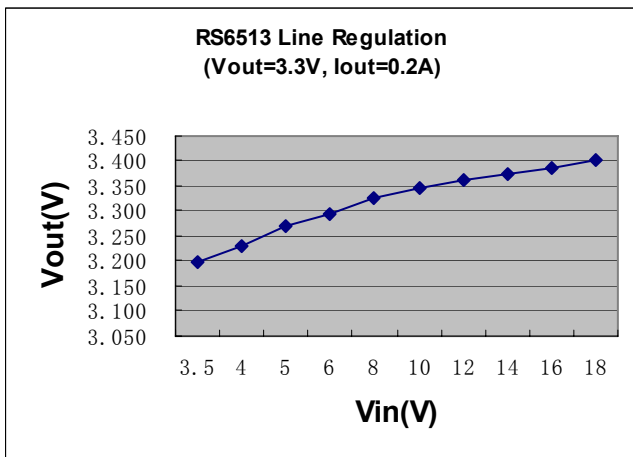

Function Description

PWM Control

The RS6513 consists of DC/DC converters that employ a pulse-width modulation (PWM) system. In converters of the RS6513, the pulse width varies in a range from 0 to 100%, according to the load current. The ripple voltage produced by the switching can easily be removed through a filter because the switching frequency remains constant. Therefore, these converters provide a low-ripple power over broad ranges of input voltage and load current.

Under Voltage Lockout

The under voltage lockout circuit of the RS6513 assures that the high-side MOSFET driver outputs remain in the off state whenever the supply voltage drops below 3.3V. Normal operation resumes once V_{CC} rises above 3.5V.

$R_{DS(ON)}$ Current Limiting

The current limit threshold is setting by the external resistor connecting from V_{CC} supply to OCSET. The internal 100uA sink current crossing the resistor sets the voltage at the pin of OCSET. When the PWM voltage is less than the voltage at OCSET, an over-current condition is triggered.

$$I_{LOAD} \times R_{DS(ON)} = I_{OCSET} \times R_{OCSET}$$

See above formula for setting the current limit value.

SOP-8L Dimension

Marking:

Pin 1 Index
Date Code
Control Code

Note: Green label is used for pb-free packing

Material:

- Lead solder plating: Sn60/Pb40 (Normal), Sn/3.0Ag/0.5Cu or Pure-Tin (Pb-free)
- Mold Compound: Epoxy resin family, flammability solid burning class: UL94V-0

DIM	Min.	Max.
A	4.85	5.10
B	3.85	3.95
C	5.80	6.20
D	1.22	1.32
E	0.37	0.47
F	3.74	3.88
G	1.45	1.65
H	4.80	5.10
I	0.05	0.20
J	0.30	0.70
K	0.19	0.25
L	0.37	0.52
M	0.23	0.28
N	0.08	0.13
O	0.00	0.15

*: Typical, Unit: mm

8-Lead SOP-8L Plastic
Surface Mounted Package
Package Code: S

Ordering Information

PART NUMBER	PIN-PACKAGE
RS6513S	SOP-8L

Soldering Methods for Orister's Products

1. Storage environment: Temperature=10°C~35°C Humidity=65%±15%
2. Reflow soldering of surface-mount devices

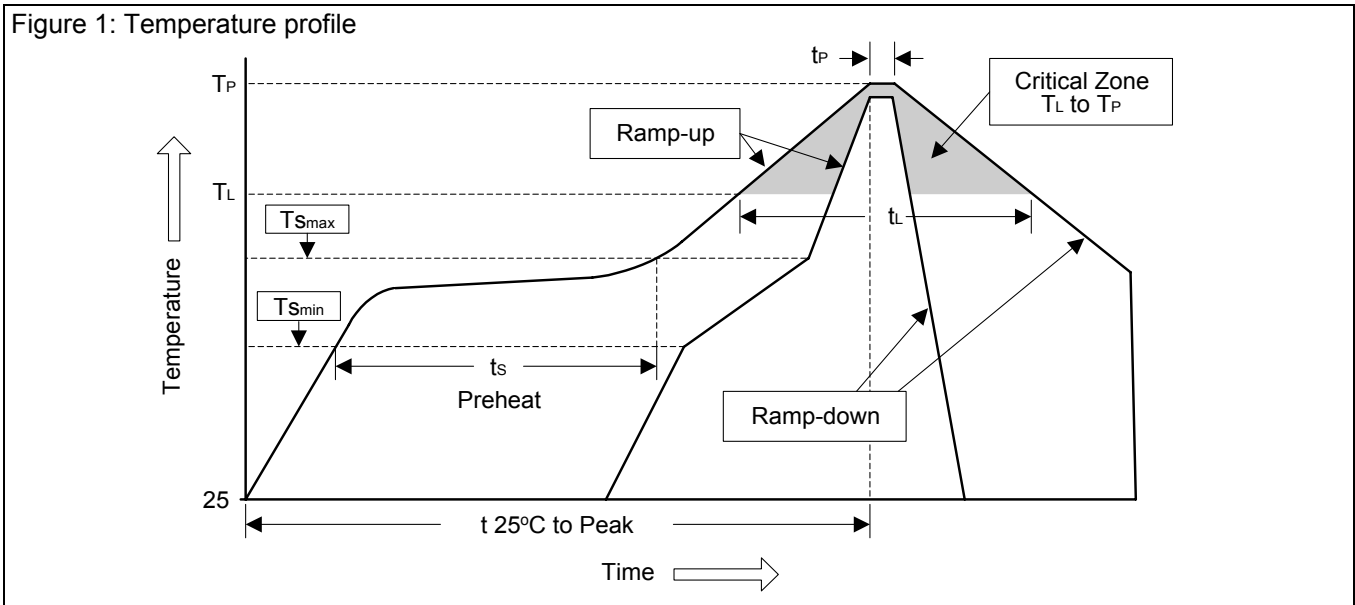

Profile Feature	Sn-Pb Eutectic Assembly	Pb-Free Assembly
Average ramp-up rate (T_L to T_P)	<3°C/sec	<3°C/sec
Preheat		
- Temperature Min (T_{Smin})	100°C	150°C
- Temperature Max (T_{Smax})	150°C	200°C
- Time (min to max) (t_s)	60~120 sec	60~180 sec
T_{Smax} to T_L		
- Ramp-up Rate	<3°C/sec	<3°C/sec
Time maintained above:		
- Temperature (T_L)	183°C	217°C
- Time (t_L)	60~150 sec	60~150 sec
Peak Temperature (T_P)	240°C +0/-5°C	260°C +0/-5°C
Time within 5°C of actual Peak Temperature (t_P)	10~30 sec	20~40 sec
Ramp-down Rate	<6°C/sec	<6°C/sec
Time 25°C to Peak Temperature	<6 minutes	<8 minutes

3. Flow (wave) soldering (solder dipping)

Products	Peak temperature	Dipping time
Pb devices.	245°C ±5°C	5sec ±1sec
Pb-Free devices.	260°C +0/-5°C	5sec ±1sec

Important Notice:

- All rights are reserved. Reproduction in whole or in part is prohibited without the prior written approval of Orister Corporation.
- Orister Corporation reserves the right to make changes to its products without notice.
- ***Orister Corporation products are not warranted to be suitable for use in Life-Support Applications, or systems.***
- Orister Corporation assumes no liability for any consequence of customer product design, infringement of patents, or application assistance.