

## FLOPPY DISK VFO

The Fujitsu MB4107A is a variable-frequency oscillator (VFO) IC for use in floppy-disk interfaces. It provides a complete data separation function, with a minimum of external parts and no adjustments, and can be used with a variety of disk controllers. It locks onto the read signal from the disk drive, which normally has jitter due to rotation speed variations and peak shifting, and produces a stable read signal for the controller. It also produces a window signal, which can be used to differentiate the clock and data pulses in the read signal.

The MB4107A includes functions for sync field detection, automatic loop filter gain switching, and address and index mark detection.

- The analog VFO (PLL) circuitry allows a wide read margin for the data separator.
- Can be connected to 8-inch, 5-inch and 3.5-inch floppy disk drives using the same external components.
- Handless, both double-density (MFM) and single-density (FM) disks.
- Can be used with various floppy disk controllers such as the MB8876A, MB8877A, FD1791, and  $\mu$ PD 765.
- The discrimination function for gap and sync fields prevents incorrect locking on the gap field.
- The quick sync function (high gain) in the sync field is automatically switched to the stable tracking function (low gain).
- Because the sync pattern detector (data: 00<sub>H</sub>, clock: FF<sub>H</sub>) and the IBM format mark detector control PLL gain, the index, ID, and data fields can be locked onto without special control signals.
- A master clock is generated for the floppy disk controller, to prevent spikes when switching between each kind of floppy disks.
- External circuitry requires very few components, and no adjustments.
- Internal clock: 7 resistors, 5 capacitor, 1 crystal or ceramic resonator
- External clock: 5 resistors, 3 capacitors

### ABSOLUTE MAXIMUM RATINGS ( $T_A = 25^\circ\text{C}$ )

| Item                | Symbol    | Condition                 | Rating      | Unit             |
|---------------------|-----------|---------------------------|-------------|------------------|
| Supply Voltage      | $V_{CC}$  |                           | 7           | V                |
| Logic Input Voltage | $V_{IN}$  |                           | 7           | V                |
| Power Dissipation   | $P_D$     | $T \leq 75^\circ\text{C}$ | 550         | mW               |
| Storage Temperature | $T_{STG}$ |                           | -55 to +125 | $^\circ\text{C}$ |

**NOTE:** Permanent device damage may occur if ABSOLUTE MAXIMUM RATINGS are exceeded. Functional operation should be restricted to the conditions as detailed in the operational sections of this data sheet. Exposure to absolute maximum rating conditions for extended periods may affect device reliability.

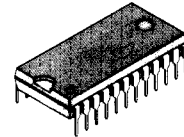

PLASTIC PACKAGE  
DIP-24P-M02

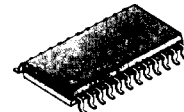

PLASTIC PACKAGE  
FPT-24P-M02

### PIN ASSIGNMENT

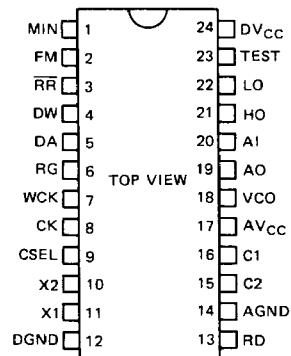

This device contains circuitry to protect the inputs against damage due to high static voltages or electric fields. However, it is advised that normal precautions be taken to avoid application of any voltage higher than maximum rated voltages to this high impedance circuit.



MB4107A

6

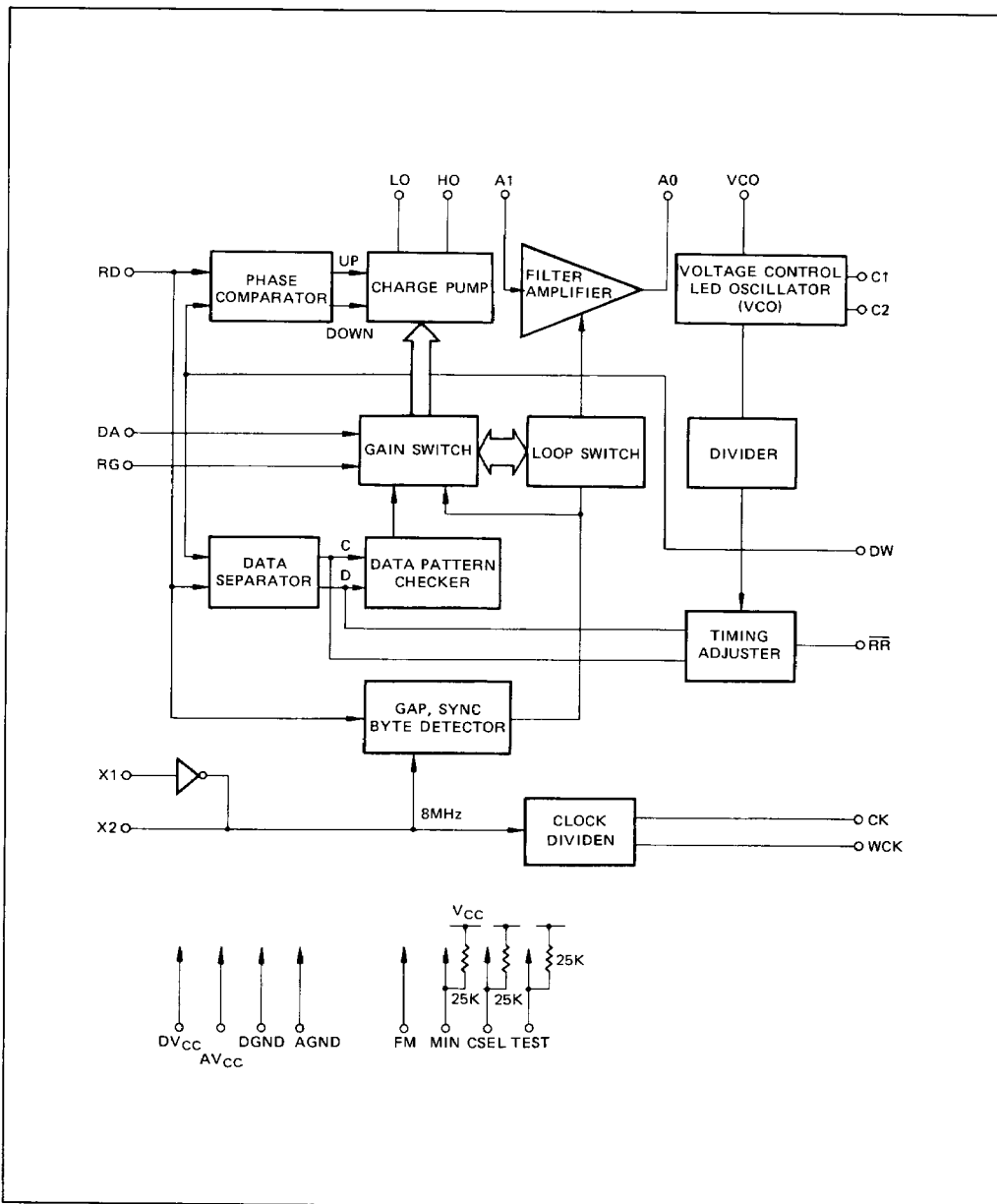

## PIN DESCRIPTION

| Pin No.  | Pin Name | Descriptions  |
|----------|----------|---|
| 1        | MIN      | Selects type of floppy disk as follows: <ul style="list-style-type: none"> <li>– 8-inch floppy disk (STD) Low</li> <li>– 5-inch, 3.5-inch floppy disk 2D, 2DD (MIN) High</li> <li>– 2HD, 2ED (3.5-inch 2MB) (STD) Low</li> </ul>  |
| 2        | FM       | Selects the disk density as follows: <ul style="list-style-type: none"> <li>– Single density (FM system) High</li> <li>– Double density (MFM system) Low</li> </ul>   |
| 3        | RR       | Read data signal for the FDC, including both clock and data pulses.   |
| 4        | DW       | Data window signal for separating the RR signal into data and clock pulses.   |
| 5        | DA       | Input for indicating a data field. When DA goes high, the PLL is kept as a low gain. Either RG or DA is used, but not both, and the unused pin is kept low.   |
| 6        | RG       | Read Gate (MB 8877A system) or VCO Sync ( $\mu$ PD765 system) input. When a high signal is applied to this pin, PLL is kept at a low gain.  |
| 7        | WCK      | The $\mu$ PD 765 system FDC write clock pulse is output from this pin as follow: <ul style="list-style-type: none"> <li>– STD 8-inch/MFM T = 1 <math>\mu</math>s</li> <li>– STD 8-inch/FM T = 2 <math>\mu</math>s</li> <li>– MIN 5-inch/MFM T = 2 <math>\mu</math>s</li> <li>– MIN 5-inch/FM T = 4 <math>\mu</math>s</li> </ul> |
| 8        | CK       | The FDC clock pulse is output from this pin as follows: <ul style="list-style-type: none"> <li>– MB 8877A system/STD 8-inch 2 MHz</li> <li>– MB 8877A system/MIN 5-inch 1 MHz</li> <li>– <math>\mu</math>PD 765 system/STD 8-inch 8 MHz</li> <li>– <math>\mu</math>PD 765 system/MIN 5-inch 4 MHz</li> </ul>                    |
| 9        | CSEL     | Selects the FDC type shown below (an internal pull-up resistor is provided): <ul style="list-style-type: none"> <li>– MB 8877A, FD 1791 system High</li> <li>– <math>\mu</math>PD 765 system Low</li> </ul>   |
| 10       | X2       | (1) Inverter output for the quartz oscillator<br>(2) This pin is open when a 8-MHz external clock is used.  |
| 11       | X1       | (1) Inverter input for the quartz oscillator<br>(2) Input pin when an 8-MHz external clock is used.   |
| 12       | DGND     | Ground for digital circuits   |
| 13       | RD       | Input for the source read data from the FDD   |
| 14       | AGND     | Ground for analog circuits such as VCO and filter amplifier   |
| 15<br>16 | C1<br>C2 | An external capacitor for setting VCO oscillating frequency is connected to these pins.   |



FUJITSU

MB4107A

### PIN DESCRIPTION (continued)

| Pin No. | Pin Name         | Descriptions  |
|---------|------------------|---|
| 17      | AV <sub>CC</sub> | Power supply for analog circuits such as the VCO and filter amplifier.  |
| 18      | VCO              | VCO control current input.  |
| 19      | AO               | Output pin for the low pass filter (LPF) amplifier in the VFO (PLL) circuit.  |
| 20      | AI               | Input pin for the LPF amplifier in the VFO (PLL) circuit  |
| 21      | HO               | Output pin to be externally connected to the LPF amplifier. This pin is selected at frequency lock after a sync field is detected. A high signal decreases the VCO frequency and a low signal increases it. (High gain) |
| 22      | LO               | Output pin to be externally connected to the LPF amplifier. This pin is selected after frequency lock, for phase synchronization. A high signal delays the VCO phase, and a low signal advances it. (Low gain)          |
| 23      | TEST             | Used for the LSI function test. It is normally open or pulled up.   |
| 24      | DV <sub>CC</sub> | Power supply pin for digital circuits.  |

6

### RECOMMENDED OPERATING CONDITIONS

| Item                        | Symbol          | Min  | Typ  | Max  | Unit |
|-----------------------------|-----------------|------|------|------|------|
| Supply voltage              | V <sub>CC</sub> | 4.75 | 5.00 | 5.25 | V    |
| Operating temperature range | T <sub>OP</sub> | -20  | 25   | 75   | °C   |

# ELECTRICAL CHARACTERISTICS

## 1 – DC CHARACTERISTICS

| Item                             | Symbol    | Condition   | Value |      |      | Unit          | Applicable pin                    | Note     |
|----------------------------------|-----------|---|-------|------|------|---------------|-----------------------------------|----------|
|                                  |           |   | Min   | Typ  | Max  |               |                                   |          |
| Supply current                   | $I_{CC}$  | $V_{CC} = 5.25 \text{ V}$                             | –     | 70   | 100  | mA            | $V_{CC}$                          | *4       |
| High level input voltage         | $V_{IH}$  | $V_{CC} = 4.75 \text{ to } 5.25 \text{ V}$            | 2.0   | –    | –    | V             | MIN, FM<br>DA, RG<br>CS, X1<br>RD | *3       |
| Low level input voltage          | $V_{IL}$  |   | –     | –    | 0.8  | V             |                                   | *3       |
| High level input current         | $I_{IH}$  | $V_{CC} = 5.25 \text{ V}, V_I = 2.7 \text{ V}$        | –     | –    | 20   | $\mu\text{A}$ | FM, DA<br>RG, X1<br>RD            | –        |
| Current at maximum input voltage | $I_I$     | $V_{CC} = 5.25 \text{ V}, V_I = 7.0 \text{ V}$        | –     | –    | 0.1  | mA            |                                   | –        |
| Low level input current          | $I_{IL}$  | $V_{CC} = 5.25 \text{ V}, V_I = 0.4 \text{ V}$        | –400  | –20  | –    | $\mu\text{A}$ |                                   | –        |
| Open-circuit input voltage       | $V_{IP}$  |   | 4.85  | 5.0  | –    | V             | MIN, CS                           | –        |
| Low level input current          | $I_{ILP}$ | $V_I = 0 \text{ V}$                                   | –1.1  | –0.6 | –    | mA            |                                   | –        |
| High level output voltage 1      | $V_{OH1}$ | $V_{CC} = 4.75 \text{ V}, I_{OH} = -1.2 \text{ mA}$   | 2.7   | 3.3  | –    | V             | RR, DW                            | *1<br>*3 |
| Low level output voltage 1       | $V_{OL1}$ | $V_{CC} = 4.75 \text{ V}$<br>$I_{OL} = 12 \text{ mA}$ | –     | 0.28 | 0.4  | V             |                                   | *2<br>*3 |
|                                  |           | $I_{OL} = 24 \text{ mA}$                              | –     | 0.35 | 0.5  | V             |                                   |          |
| Short-circuit output current 1   | $I_{OS1}$ | $V_{CC} = 5.25 \text{ V}$                             | –30   | –    | –160 | mA            | *1<br>*3                          |          |
| High level output voltage 2      | $V_{OH2}$ | $V_{CC} = 4.75 \text{ V}, I_{OH} = -0.4 \text{ mA}$   | 2.7   | 3.3  | –    | V             | WCK, CK                           | *1<br>*3 |
| Low level output voltage 2       | $V_{OL2}$ | $V_{CC} = 4.75 \text{ V}$<br>$I_{OL} = 4 \text{ mA}$  | –     | 0.28 | 0.4  | V             |                                   | *2<br>*3 |
|                                  |           | $I_{OL} = 8 \text{ mA}$                               | –     | 0.35 | 0.5  | V             |                                   |          |
| Short-circuit output current 2   | $I_{OS2}$ | $V_{CC} = 5.25 \text{ V}$                             | –20   | –    | –110 | mA            | *1<br>*3                          |          |
| High level output voltage 3      | $V_{OH3}$ | $V_{CC} = 4.75 \text{ V}, I_{OH} = -0.4 \text{ mA}$   | 2.7   | 3.3  | –    | V             | X2                                | *1<br>*3 |
| Low level output voltage 3       | $V_{OL3}$ | $V_{CC} = 4.75 \text{ V}, I_{OL} = 1 \text{ mA}$      | –     | 0.28 | 0.4  | V             |                                   | *2<br>*3 |
| High output voltage              | $V_{HH}$  | $I_{OH} = -1 \text{ mA}$                              | 3.3   | 3.7  | –    | V             | HO                                | *1       |
| Low output voltage               | $V_{LH}$  | $I_{OL} = 1 \text{ mA}$                               | –     | 2.0  | 2.4  | V             |                                   | *2       |
| High output voltage              | $V_{HL}$  | $I_{OH} = -0.2 \text{ mA}$                            | 3.8   | 4.2  | –    | V             | LO                                | *1       |
| Low output voltage               | $V_{LL}$  | $I_{OL} = 0.2 \text{ mA}$                             | –     | 1.5  | 1.9  | V             |                                   | *2       |
| VCO free run frequency           | $f_{FR}$  |   | 1.6   | 2.0  | 2.4  | MHz           |                                   | –        |

NOTE: \*1 The output stage is set high. \*2 The output stage is set low. \*3  $T_A = -20^\circ\text{C}$  to  $75^\circ\text{C}$

\*4  $V_{CC}$  is connected with A,  $V_{CC}$  & D,  $V_{CC}$ .

**2 – AC CHARACTERISTICS**

 (V<sub>CC</sub> = 5V, f<sub>X1</sub> = 8MHz)

| Item                              | Symbol           | Condition                     |                       | Value |      |     | Unit | Applicable Pin |     |
|-----------------------------------|------------------|-------------------------------|-----------------------|-------|------|-----|------|----------------|-----|
|                                   |                  |                               |                       | Min   | Typ  | Max |      |                |     |
| Rising Time                       | T <sub>r</sub>   | C <sub>L</sub> = 25pF         |                       |       | 3    |     | ns   | CK             |     |
| Falling Time                      | T <sub>f</sub>   |                               |                       |       | 2    |     |      |                |     |
| Frequency                         | f <sub>CK</sub>  | CSEL = "H"<br>MB8876A         | MIN = "L"             |       | 2    |     | MHz  |                |     |
|                                   |                  |                               | MIN = "H"             |       | 1    |     |      |                |     |
|                                   |                  | CSEL = "L"<br>μPD765          | MIN = "L"             |       | 8    |     |      |                |     |
|                                   |                  |                               | MIN = "H"             |       | 4    |     |      |                |     |
| Duty Ratio                        | DR <sub>CK</sub> | CSEL = "H"<br>CSEL = "L"      | C <sub>L</sub> = 25pF |       | 50   |     | %    |                |     |
|                                   |                  |                               |                       |       | 50   |     |      |                |     |
| Rising Time                       | T <sub>r</sub>   | C <sub>L</sub> = 25pF         |                       |       | 3    |     | ns   |                | WCK |
| Falling Time                      | T <sub>f</sub>   |                               |                       |       | 2    |     |      |                |     |
| Cycle Time                        | T <sub>CY</sub>  | MIN = "L"                     | MFM = "H"             |       | 1    |     | μs   |                |     |
|                                   |                  |                               | MFM = "L"             |       | 2    |     |      |                |     |
|                                   |                  | MIN = "H"                     | MFM = "H"             |       | 2    |     |      |                |     |
|                                   |                  |                               | MFM = "L"             |       | 4    |     |      |                |     |
| "H" Level Width                   | T <sub>WH</sub>  | MIN = "L"                     | MFM = "H"             |       | 125  |     | ns   |                |     |
|                                   |                  |                               | MFM = "L"             |       | 125  |     |      |                |     |
|                                   |                  | MIN = "H"                     | MFM = "H"             |       | 250  |     |      |                |     |
|                                   |                  |                               | MFM = "L"             |       | 250  |     |      |                |     |
| Rising Time                       | T <sub>r</sub>   | C <sub>L</sub> = 25pF         |                       |       | 3    |     | ns   |                |     |
| Falling Time                      | T <sub>f</sub>   |                               |                       |       | 2    |     |      |                |     |
| Window Width<br>("H" Level Width) | T <sub>w</sub>   | MIN = "L"                     | MFM = "H"             |       | 1    |     | μs   | DW             |     |
|                                   |                  |                               | MFM = "L"             |       | 2    |     |      |                |     |
|                                   |                  | MIN = "H"                     | MFM = "H"             |       | 2    |     |      |                |     |
|                                   |                  |                               | MFM = "L"             |       | 4    |     |      |                |     |
| Rising Time                       | T <sub>r</sub>   | C <sub>L</sub> = 25pF         |                       |       | 3    |     | ns   | RR             |     |
| Falling Time                      | T <sub>f</sub>   |                               |                       |       | 2    |     |      |                |     |
| "L" Level Width                   | T <sub>WL</sub>  | MIN = "L"                     | MFM = "H"             |       | 0.25 |     | μs   |                |     |
|                                   |                  |                               | MFM = "L"             |       | 0.5  |     |      |                |     |
|                                   |                  | MIN = "H"                     | MFM = "H"             |       | 0.5  |     |      |                |     |
|                                   |                  |                               | MFM = "L"             |       | 1    |     |      |                |     |
| Slip Off from DW Center           | T <sub>D</sub>   |                               |                       |       | 10   |     | ns   |                |     |
| "H" Level Width                   | T <sub>WH</sub>  |                               |                       | 50    |      |     | ns   |                | RD  |
| External Clock Duty Ratio         | D <sub>EXT</sub> | f <sub>X1</sub> = 8MHz/9.6MHz |                       | 40    | 50   | 60  | %    | X1             |     |

**STANDARD EXTERNAL CIRCUITS (MB4107A)**

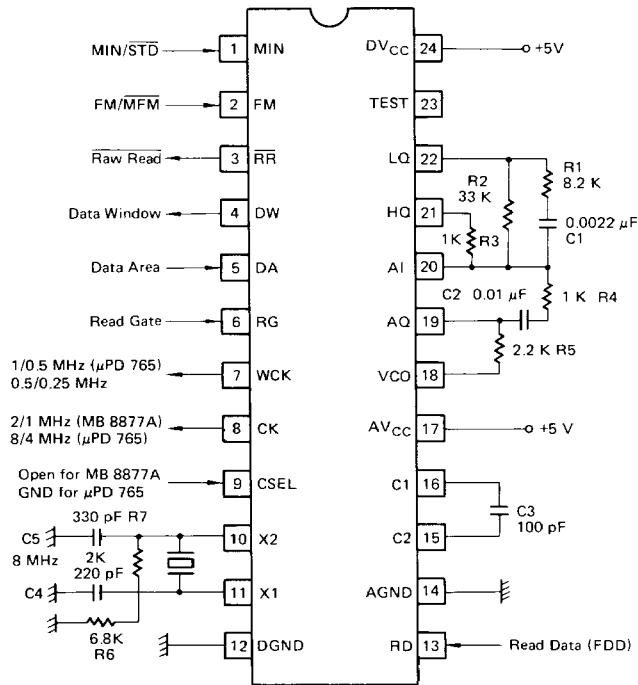

- NOTE: 1. C<sub>3</sub> (±5%), R<sub>5</sub> (±1%), otherwise C (±10%), R (±5%)  
 2. Since the 8-MHz internal and 8-MHz external clocks require precision of ±1%, a ceramic resonator can be used when WCK and CK do not require a high precision.

**TIMING CHARTS**

**I 8 INCH, MFM, HIGH GAIN (SYNC FIELD)**

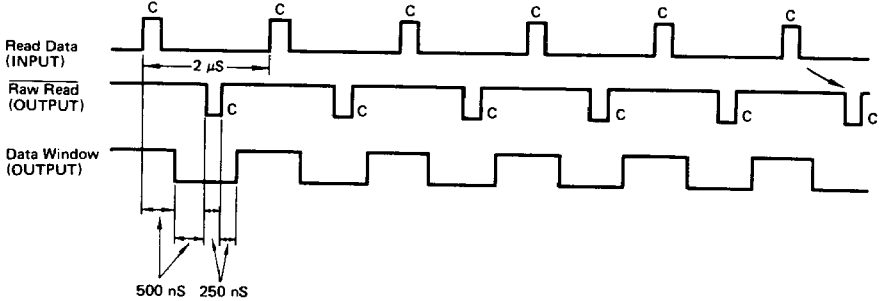

**II 8 INCH, MFM, LOW GAIN**

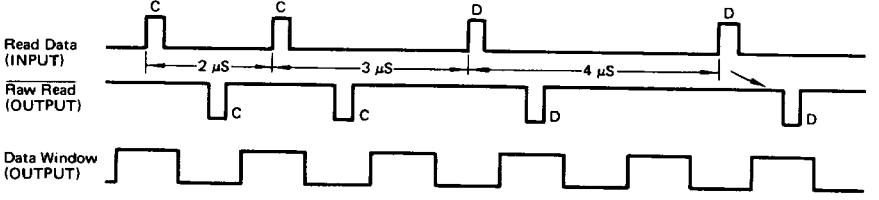

**III 8 INCH, FM, LOW GAIN.**

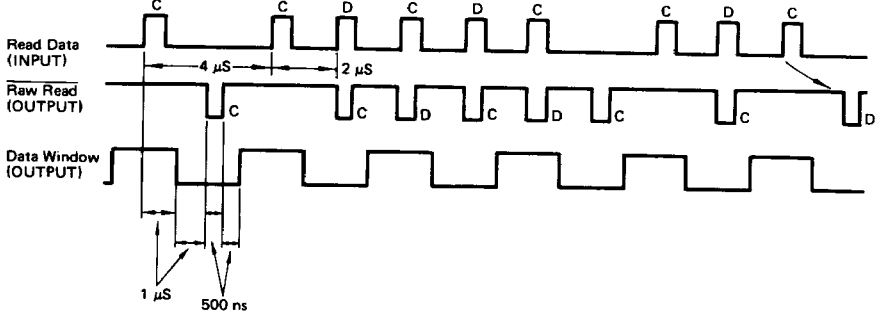

NOTES: 1. The above times are doubled for 5-inch floppy disks.  
 2. C = clock pulse, D = data pulse

**6**



## STANDARD CONNECTION

**1. MB8876/77A**  
**1-1) Read Gate**

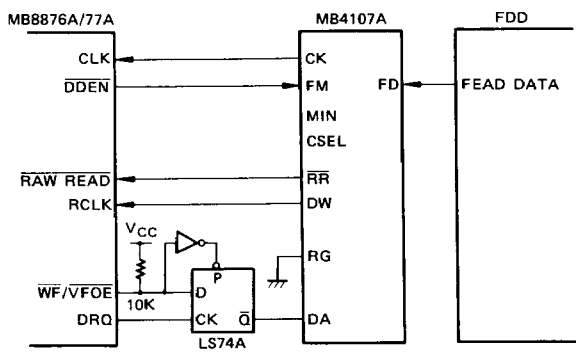
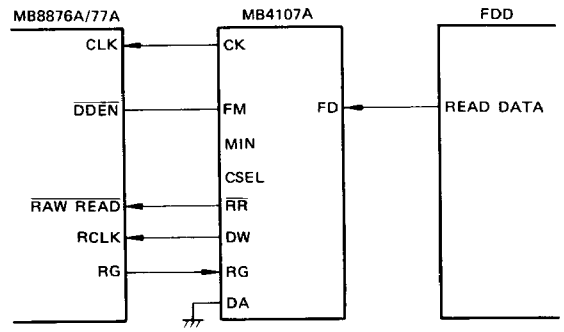

**1-2) Data Request**

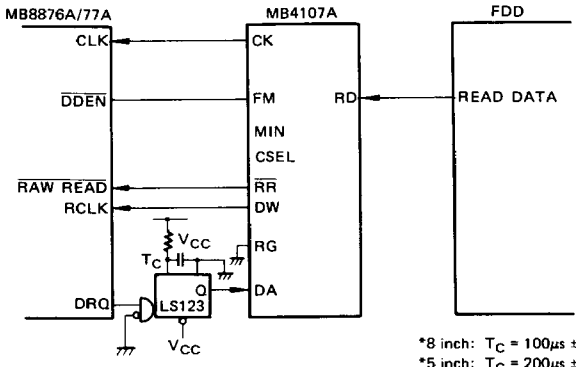

\*8 inch: T<sub>C</sub> = 100μs ± 20%  
 \*5 inch: T<sub>C</sub> = 200μs ± 20%

## STANDARD CONNECTIONS (continued)

### 2. $\mu$ PD765

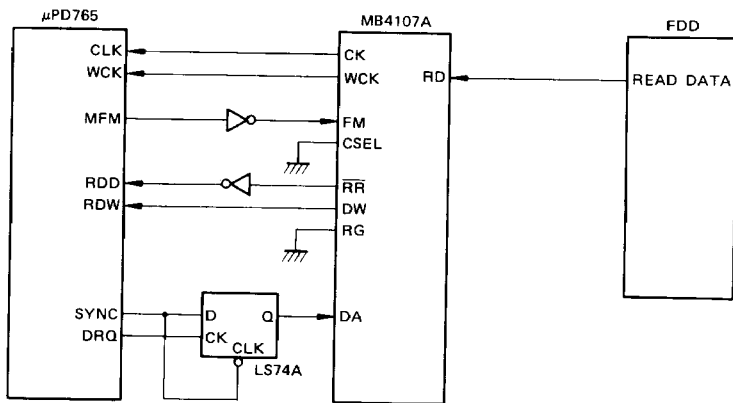
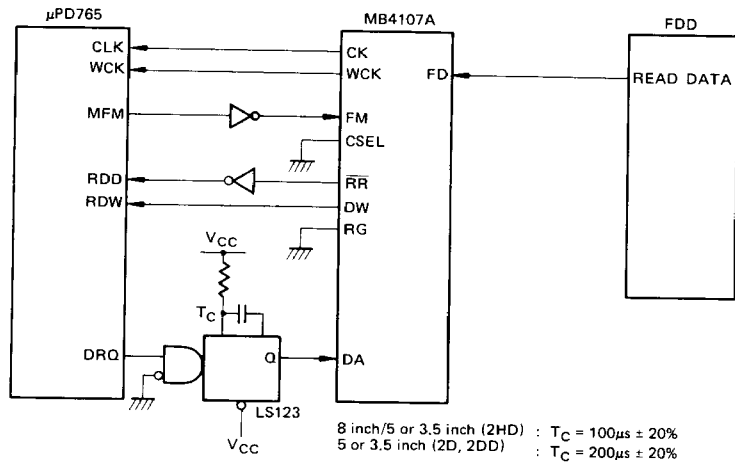

6

## CK, WCK TIMING (EXTERNAL CLOCK INPUT)

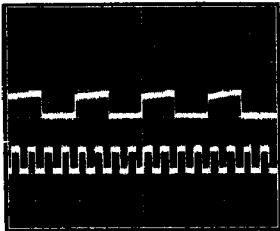
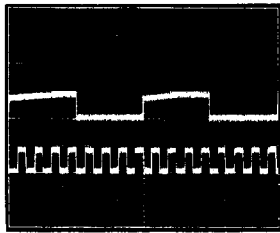
| Mode  | In/Output        | Timing  |
|---|------------------|---|
| CSEL = "H"<br>MB8876A<br>MB8877A<br><br>STD<br>MFM/FM | CK<br><br><br>X1 |  |
| CSEL = "H"<br>MB8876A<br>MB8877A<br><br>MIN<br>MFM/FM | CK<br><br><br>X1 |  |

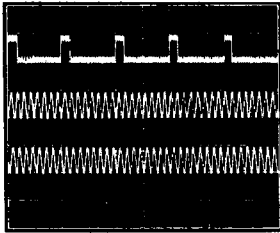
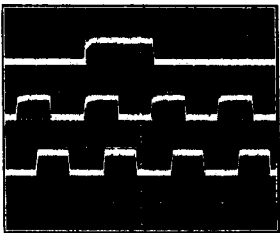
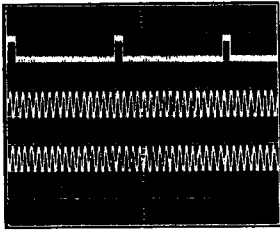
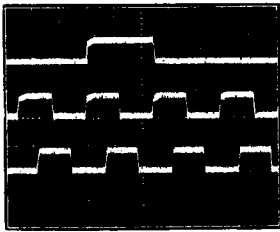
| Mode   | In/Output               | Timing  | Magnification  |
|--|-------------------------|---|--|
| CSEL = "L"<br>( $\mu$ PD765)<br><br>STD<br>MFM | WCK<br><br>CK<br><br>X1 |  |  |
| CSEL = "L"<br>( $\mu$ PD765)<br><br>STD<br>FM  | WCK<br><br>CK<br><br>X1 |  |  |

## CK, WCK TIMING (EXTERNAL CLOCK INPUT) (continued)

| Mode                         | In/Output | Timing | Magnification |
|------------------------------|-----------|--------|---------------|
| CSEL = "L"<br>( $\mu$ PD765) | WCK       |        |               |
| MIN                          | CK        |        |               |
| MFM                          | X1        |        |               |
| CSEL = "L"<br>( $\mu$ PD765) | WCK       |        |               |
| MIN                          | CK        |        |               |
| FM                           | X1        |        |               |

6

Delay of CW, WCK against input clock

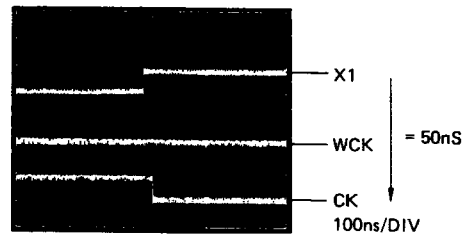
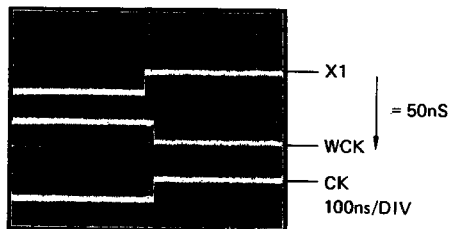
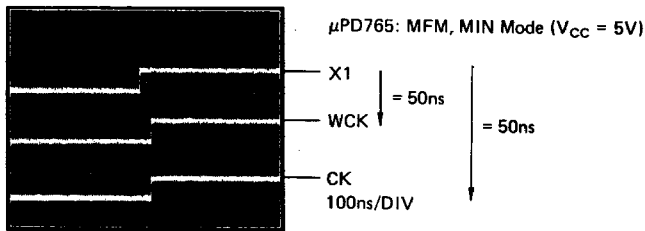

## TYPICAL PERFORMANCE CHARACTERISTICS

Fig. 1 –  $f_{V10}$  vs. VAD

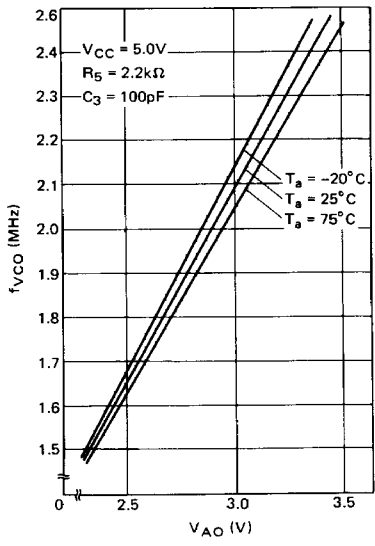

Fig. 2 – FREE RUN FREQUENCY vs.  $C_3$

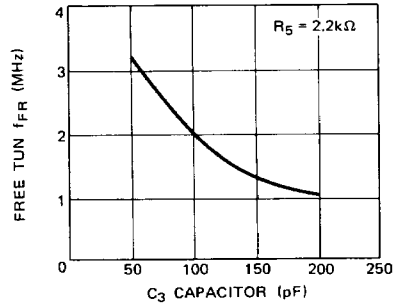

Fig. 3 – FREE RUN FREQUENCY vs.  $T_a$

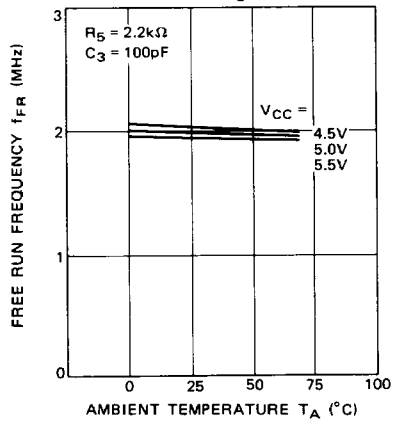
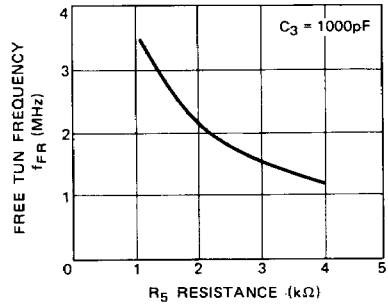

Fig. 4 – FREE RUN FREQUENCY vs.  $R_5$



## TYPICAL PERFORMANCE CHARACTERISTICS (continued)

Fig. 5 - TIME MARGIN vs.  $T_A$

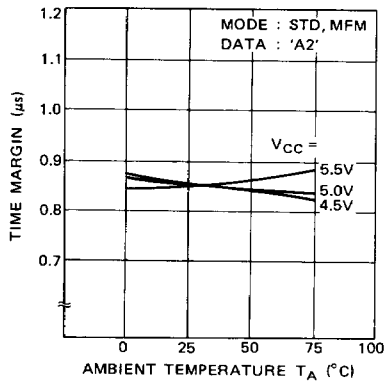

Fig. 6 - TIME MARGIN vs. FREE RUN FREQUENCY

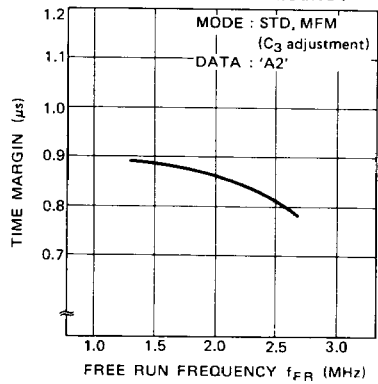
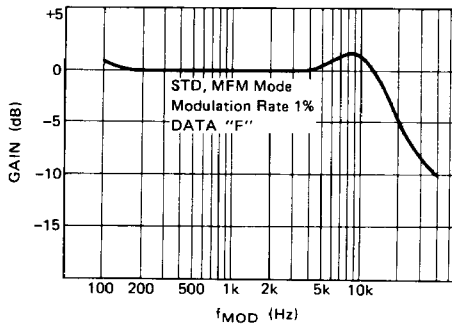
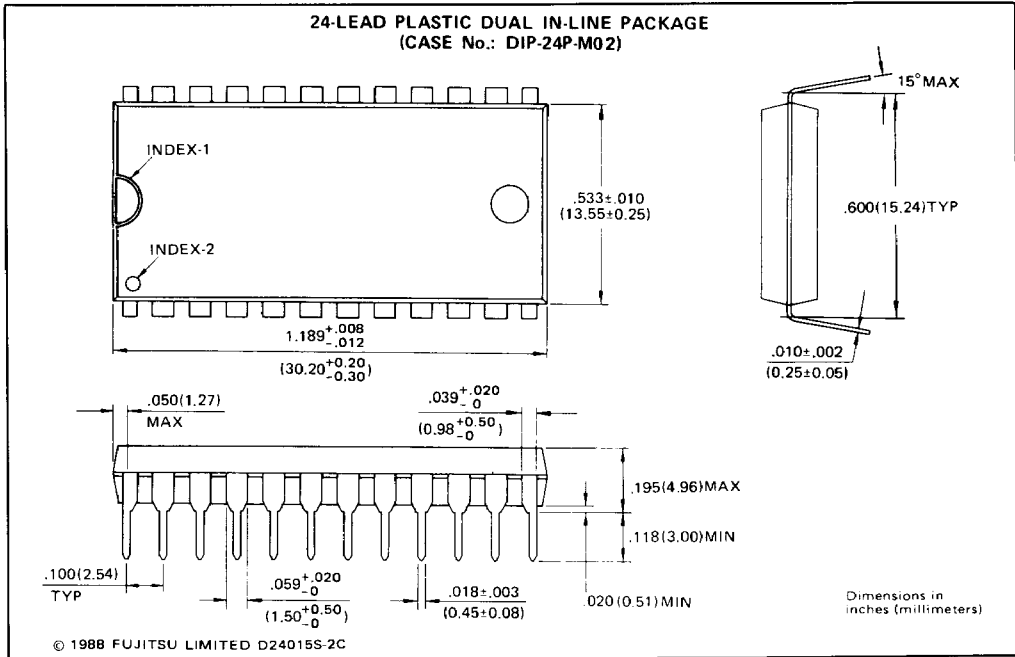

Fig. 7 - GAIN vs.  $f_{MOD}$



## PACKAGE DIMENSIONS





MB4107A

# PACKAGE DIMENSIONS (continued)

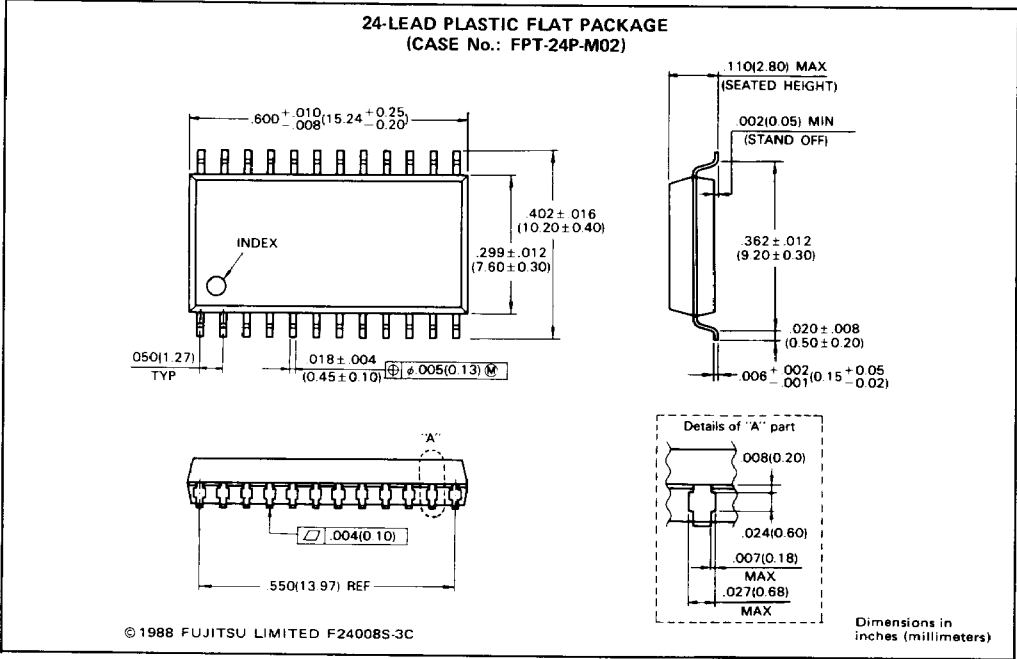

© 1988 FUJITSU LIMITED F24008S-3C

6