

Agilent VTO-3981-K, VTO-4301-K Voltage Controlled Oscillator

Data Sheet



Description

The VTO-3981-K and VTO-4301-K provide a fundamental, low jitter source as a key component for the data re-timing in the transmitter subsystem and clock and data recovery in the receiver of the 40 Gb fiber optic systems.

The oscillator uses an extremely high performance low noise Agilent Silicon Bipolar transistor in conjunction with a hyper-abrupt varactor diode to provide the tuning capability. The oscillator output is then coupled to an Agilent GaAs FET MMIC amplifier and MMIC multiplier chain to quadruple the frequency. Finally the output is filtered through a band pass filter prior to outputting the signal at 39.813 GHz or 43.018 GHz.

Functional Block Diagram

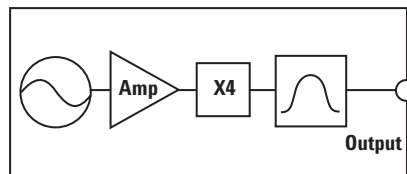

Features

- Operating frequency:
39.813 GHz or 43.018 GHz
- Output power (50Ω load):
3 dBm minimum
- Modulation sensitivity:
20 to 40 MHz/V
- Tuning voltage:
0 to 10 Volts
- Low jitter (Less than 50 femto seconds from 50 KHz to 80 MHz)
- Frequency drift over 0°C to +75°C:
80 MHz
- 1.181" x 0.95" x 0.4"
- 5 Volt bias optional

Applications

- Transmitter and receiver sub-systems for OC-768/STM-256 applications
- 40 GHz source

VTO-3981-K, VTO-4301-K Absolute Maximum Ratings^[1]

Parameter	Units	Ratings
Positive Supply Voltage	V	0 to +10
Negative Supply Voltage	V	0 to -6
Tuning Voltage	V	0 to +12
Operating Temperature	°C	0 to +85
Storage Temperature	°C	-40 to +130

Note:

1. Operation of this device in excess of any of these limits may cause permanent damage.



Agilent Technologies

VTO-3981-K, VTO-4301-K Summary Characterization, 0°C to 75°C

Parameter	Units	Min	Typ	Max
Frequency Range, f_0	GHz		39.813 or 43.018	
Vt @ 39.813 GHz	V	0		10
Power Output (50Ω Load)	dBm	3		7
Modulation Sensitivity	MHz/V	20		40
Modulation Sensitivity Variation	%	-20		20
Modulation Bandwidth	MHz	100		
Output Return Loss	dB	10	12	
Second Harmonic (Below Carrier)	dBc			-20
Third Harmonic (Below Carrier)	dBc			-20
Sub Harmonically Related Spurious	dBc			-30
Spurious Output (Below Carrier)	dBc			-65
Phase Noise @ 100 KHz from F_0 (Below Carrier)	dBc/Hz		-95	-90
Frequency Drift over Temperature	MHz			80
Pulling Figure (12 dB Return Loss)	MHz			2
Pushing Figure, $\pm 0.2V$ Supply	MHz			20
Tuning Port Input Capacitance	pF		12	
Positive Supply Voltage	V	7.8		8.2
Positive Supply Current	mA			150
Negative Supply Voltage	V	-4.8		-5.2
Negative Supply Current	mA			15

Typical Performance Curves @ +25°C

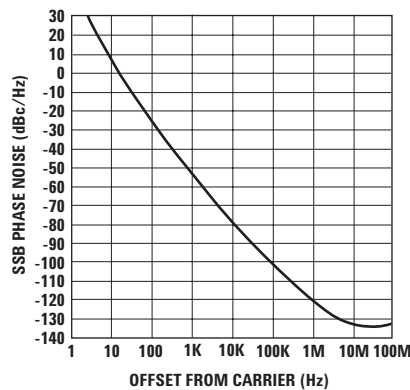

Figure 1. Typical Phase Noise Performance.

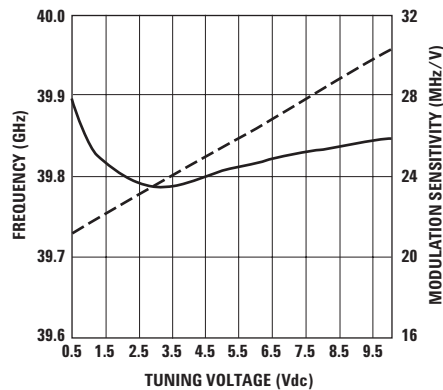

Figure 2. Frequency and Modulation Sensitivity vs. Tuning Voltage.

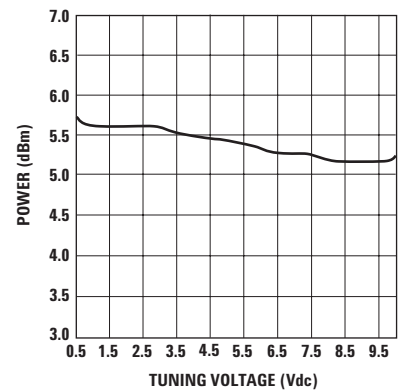

Figure 3. Power Output.

Ordering Information

Part Number

VTO-3981-K	SONET/SDH 39.813 GHz
VTO-4301-K	FEC 43.018 GHz

Package Drawing and Mechanical Dimensions (inches)

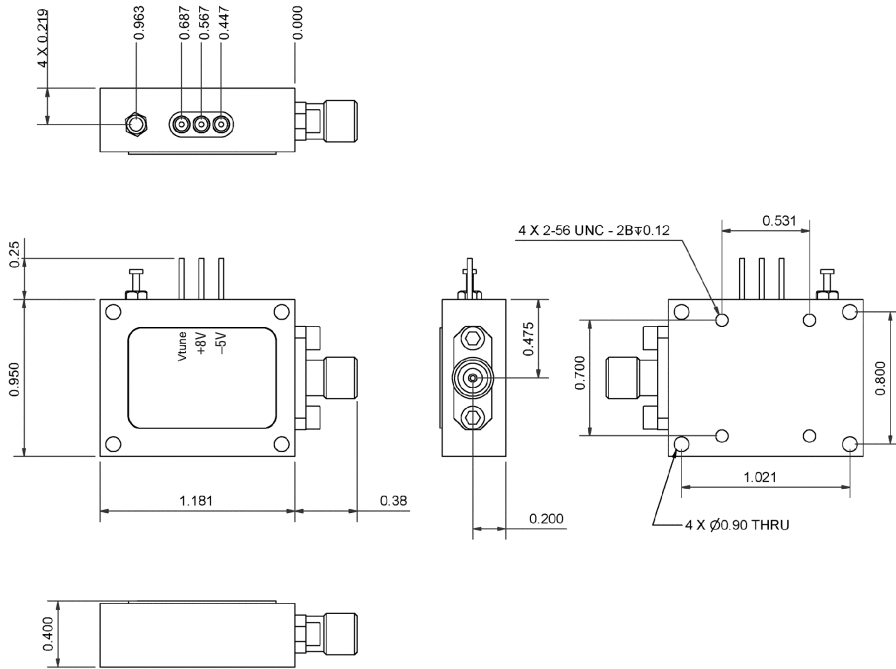

www.agilent.com/semiconductors

For product information and a complete list of distributors, please go to our web site.

For technical assistance call:

Americas/Canada: +1 (800) 235-0312 or
(408) 654-8675

Europe: +49 (0) 6441 92460

China: 10800 650 0017

Hong Kong: (+65) 6271 2451

India, Australia, New Zealand: (+65) 6271 2394

Japan: (+81 3) 3335-8152(Domestic/International), or
0120-61-1280(Domestic Only)

Korea: (+65) 6271 2194

Malaysia, Singapore: (+65) 6271 2054

Taiwan: (+65) 6271 2654

Data subject to change.

Copyright © 2002 Agilent Technologies, Inc.

July 23, 2002

5988-6977EN



Agilent Technologies