

- In accordance with IEC 60431
- Cores without center hole for transformer applications
- RM cores are supplied in sets

Magnetic characteristics (per set)

	with center hole	without center hole	
$\Sigma I/A$	0,67	0,59	mm ⁻¹
l_e	35,1	38	mm
A_e	52	64	mm ²
A_{min}	—	55	mm ²
V_e	1 840	2 430	mm ³

Approx. weight (per set)

m	10,7	12	g

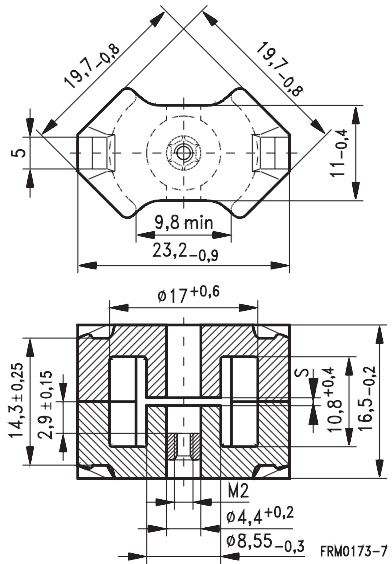
Gapped

Material	A_L value	s approx. mm	μ_e	Ordering code ¹⁾ -D with center hole -F with threaded sleeve -J without center hole
	nH			
N48	250 ± 3 %	0,23	133	B65811-+250-A48
	315 ± 3 %	0,17	168	B65811-+315-A48
	400 ± 3 %	0,14	213	B65811-+400-A48
	630 ± 5 %	0,10	336	B65811-+630-J48
N41	160 ± 3 %	0,49	76	B65811-J160-A41
	250 ± 5 %	0,24	117	B65811-J250-J41
	630 ± 5 %	0,11	298	B65811-J630-J41
	1600 ± 10 %	0,04	752	B65811-J1600-K41
N87	250 ± 3 %	0,30	118	B65811-J250-A87
	400 ± 3 %	0,18	189	B65811-J400-A87

1) Replace the + by the code letter "F" or "D" for the required version. Standard version is "D".

Ungapped

Material	A_L value nH	μ_e	A_{L1min} nH	P_V W/set	Ordering code -D with center hole -J w/o center hole
N26	2900 + 30/- 20 %	1550			B65811-D-R26
N30	5700 + 30/- 20 %	2680			B65811-J-R30
T38	12500 + 40/- 30 %	5870			B65811-J-Y38
N49	2200 + 30/- 20 %	1040	1270	< 0,37 (50 mT, 500 kHz, 100 °C)	B65811-J-R49
N87	3300 + 30/- 20 %	1560	1900	< 1,20 (200 mT, 100 kHz, 100 °C)	B65811-J-R87
N97 ¹⁾	3300 + 30/- 20 %	1560	1900	< 1,00 (200 mT, 100 kHz, 100 °C)	B65811-J-R97
N41	4100 + 30/- 20 %	1930	1900	< 0,36 (200 mT, 25 kHz, 100 °C)	B65811-J-R41

1) Preliminary data

Coil former, squared pins

Material: GFR thermosetting plastic (UL 94 V-0, insulation class to IEC 60085:
H \geq max. operating temperature 180 °C), color code black

Solderability: to IEC 60068-2-20, test Ta, method 1 (aging 3): 235 °C, 2 s

Resistance to soldering heat: to IEC 60068-2-20, test Tb, method 1B: 350 °C, 3,5 s

Winding: see "Processing Notes", page 153

For matching clamp and insulating washers see page 230

Sections	A_N mm ²	l_N mm	A_R value $\mu\Omega$	Pins	Ordering code
1	30	42	47	5 8 8 12	B65812-N1005-D1 B65812-N1008-D1 B65812-W1008-D1 B65812-N1012-D1
2	28,4	42	50	5 8	B65812-N1005-D2 B65812-N1008-D2

12 pins

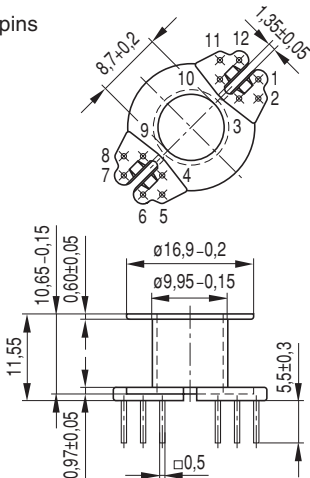

Version	Pins omitted
5 pins	3, 4, 6, 7, 9, 10, 12
8 pins	3, 4, 9, 10

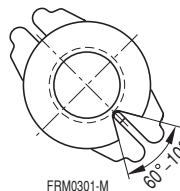
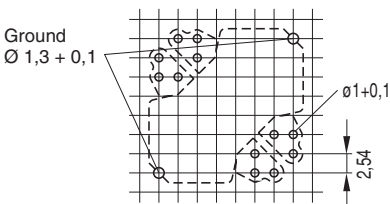

Coil former, pins squared in the start-of-winding area

Material: GFR thermosetting plastic (UL 94 V-0, insulation class to IEC 60085:

H $\hat{=}$ max. operating temperature 180 °C), color code blue

Solderability: to IEC 60068-2-20, test Ta, method 1 (aging 3): 235 °C, 2 s

Resistance to soldering heat: to IEC 60068-2-20, test Tb, method 1B: 350 °C, 3,5 s

Winding: see "Processing Notes", page 153

For matching clamp and insulating washers see page 230

Sections	A_N mm ²	l_N mm	A_R value $\mu\Omega$	Pins	Ordering code
1	30	42	47	5	B65812-K1005-D1
				8	B65812-K1008-D1
				12	B65812-K1012-D1
2	28,4	42	50	5	B65812-K1005-D2
				12	B65812-K1012-D2

5 and 8 pins*)

12 pins

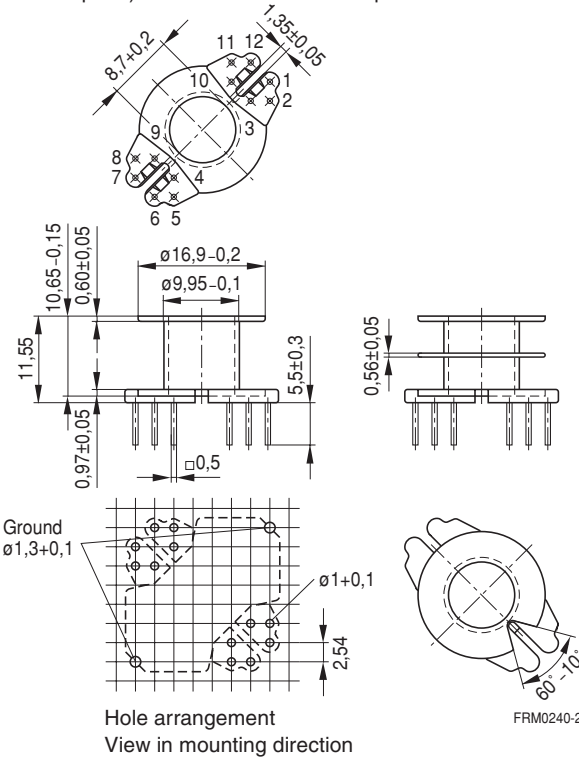

*) Pins 6, 7 and 12 are omitted in the 5-pin version

Coil former for SMPS transformers with line isolation

The creepage distances and clearances are designed such that the coil former is suitable for use in SMPS transformers with line isolation.

- Closed center flange with external wire guide
- Pins squared in the start-of-winding area
- Optimized for use with automatic winding machines

Material: GFR thermosetting plastic (UL 94 V-0, insulation class to IEC 60085:
F \triangleq max. operating temperature 155 °C), color code green

Solderability: to IEC 60068-2-20, test Ta, method 1 (aging 3): 235 °C, 2 s

Resistance to soldering heat: to IEC 60068-2-20, test Tb, method 1B: 350 °C, 3,5 s

Winding: see "Processing Notes", page 153

Sections	A_N mm ²	l_N mm	A_R value $\mu\Omega$	Pins	Ordering code
2	28,4	42	50	8	B65812-X1108-D2

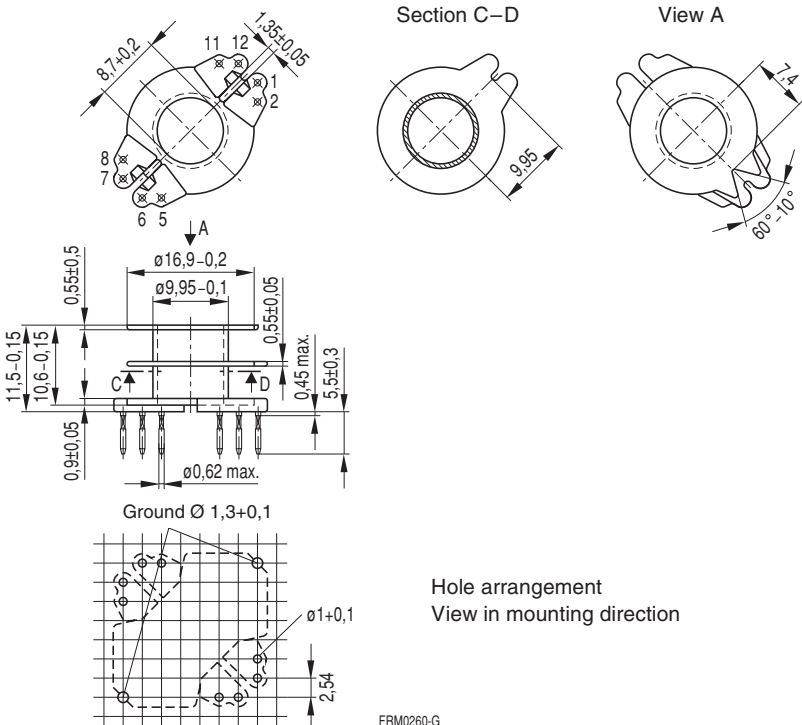

FRM0260-G

Coil former for power applications

Optimized for automatic winding

Material: GFR polyterephthalate (UL 94 V-0, insulation class to IEC 60085:

 $F \triangleq$ max. operating temperature 155 °C), color code black

Solderability: to IEC 60068-2-20, test Ta, method 1 (aging 3): 235 °C, 2 s

Resistance to soldering heat: to IEC 60068-2-20, test Tb, method 1B: 350 °C, 3,5 s

Winding: see "Processing Notes", page 153

For matching clamp and insulating washer 1 see page 230

Sections	A_N mm ²	l_N mm	A_R value $\mu\Omega$	Pins	Ordering code
1	30	42	47	12	B65812-C1512-T1

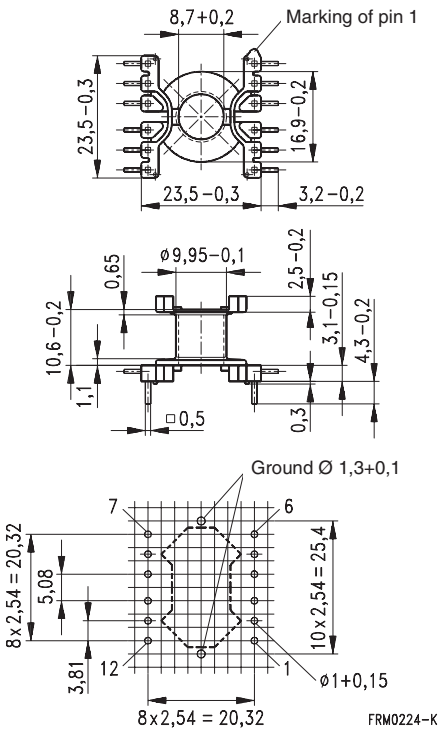

Hole arrangement
View in mounting direction
(Note half pitch!)

Clamp

- With ground terminal, made of stainless spring steel (tinned), 0,4 mm thick
- Solderability to IEC 60068-2-20, test Ta, method 1 (aging 3): 235 °C, 2 s
- Also available as strip clamp on reels

Insulating washer 1 between core and coil former

- For tolerance compensation and for insulation
- Made of polycarbonate (UL 94 V-0, insulation class to IEC 60085: E \geq 120 °C), 0,08 mm thick

Insulating washer 2 for double-clad PCBs

- Made of polycarbonate (UL 94 V-0, insulation class to IEC 60085: E \geq 120 °C), 0,3 mm thick

	Ordering code
Clamp (ordering code per piece, 2 are required)	B65812-A2203
Insulating washer 1 (reel packing, PU = 1 reel)	B65812-A5000
Insulating washer 2 (bulk)	B65812-C2005

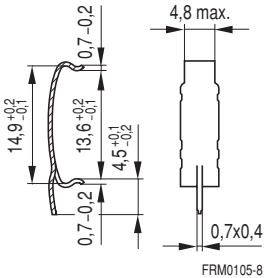
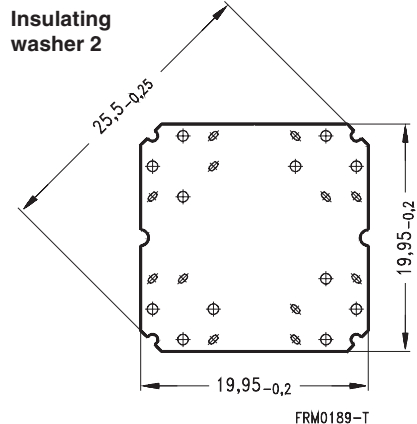
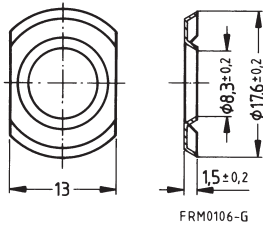
Clamp

Insulating washer 1

RM 8	B63399
Accessories	B65812

Adjusting screw

- Tube core with thread and core brake made of GFR polyterephthalate
- Plastic **adjusting screwdriver** (not shown)
- Plastic **handle** for adjusting screwdriver (not shown)

Core RM 8		Adjusting screw			Min. adjusting range %	Ordering code
Material	A _L value nH	Tube core Ø × length mm	Material	Color code		
N 48	250	4,18 × 5,0	Si 1	white	12	B65812-B3001-X101
	315	3,85 × 5,0	N 22	gray	13	B65812-B3003-X22
	400	4,18 × 4,0	N 22	brown	17	B65812-B3002-X22
	630	4,18 × 5,0	N 22	black	9	B65812-B3001-X22
Adjusting screwdriver						B63399-B1
Handle						B63399-B5

Adjusting screw

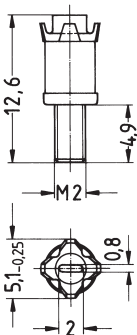

FRM0108-X

Herausgegeben von EPCOS AG

Marketing Kommunikation, Postfach 80 17 09, 81617 München, DEUTSCHLAND

© EPCOS AG 2000. Alle Rechte vorbehalten. Vervielfältigung, Veröffentlichung, Verbreitung und Verwertung dieser Broschüre und ihres Inhalts ohne ausdrückliche Genehmigung der EPCOS AG nicht gestattet.

Mit den Angaben in dieser Broschüre werden die Bauelemente spezifiziert, keine Eigenschaften zugesichert. Bestellungen unterliegen den vom ZVEI empfohlenen Allgemeinen Lieferbedingungen für Erzeugnisse und Leistungen der Elektroindustrie, soweit nichts anderes vereinbart wird.

Diese Broschüre ersetzt die vorige Ausgabe.

Fragen über Technik, Preise und Liefermöglichkeiten richten Sie bitte an den Ihnen nächstgelegenen Vertrieb der EPCOS AG oder an unsere Vertriebsgesellschaften im Ausland.

Bauelemente können aufgrund technischer Erfordernisse Gefahrstoffe enthalten. Auskünfte darüber bitten wir unter Angabe des betreffenden Typs ebenfalls über die zuständige Vertriebsgesellschaft einzuholen.

Published by EPCOS AG

Marketing Communications, P.O. Box 80 17 09, 81617 Munich, GERMANY

© EPCOS AG 2000. All Rights Reserved. Reproduction, publication and dissemination of this brochure and the information contained therein without EPCOS' prior express consent is prohibited.

The information contained in this brochure describes the type of component and shall not be considered as guaranteed characteristics. Purchase orders are subject to the General Conditions for the Supply of Products and Services of the Electrical and Electronics Industry recommended by the ZVEI (German Electrical and Electronic Manufacturers' Association), unless otherwise agreed.

This brochure replaces the previous edition.

For questions on technology, prices and delivery please contact the Sales Offices of EPCOS AG or the international Representatives.

Due to technical requirements components may contain dangerous substances. For information on the type in question please also contact one of our Sales Offices.