

# TA8251AH

## MAX POWER 30W BTL×4CH AUDIO POWER IC

The TA8251AH is 4ch BTL audio power amplifier for consumer application.

It is designed low distortion ratio for 4ch BTL audio power amplifier, built-in Stand-by Function, Muting Function and Junction Temperature Detection Circuit. Additionally, the AUX. amplifier is built-in, it can make the beep signal etc. output to 2 channels (OUT1 and 4). It contains various kind of protectors for car audio.

### FEATURES

- High power
  - :  $P_{OUT} (MAX) = 30W$  (Typ.)  
( $V_{CC} = 13.7V$ ,  $f = 1kHz$ ,  $R_L = 4\Omega$ )
  - :  $P_{OUT} (1) = 21W$  (Typ.)  
( $V_{CC} = 14.4V$ ,  $f = 1kHz$ ,  $THD = 10\%$ ,  $R_L = 4\Omega$ )
  - :  $P_{OUT} (2) = 18W$  (Typ.)  
( $V_{CC} = 13.2V$ ,  $f = 1kHz$ ,  $THD = 10\%$ ,  $R_L = 4\Omega$ )
- Low distortion ratio
  - :  $THD = 0.02\%$  (Typ.)  
( $V_{CC} = 13.2V$ ,  $f = 1kHz$ ,  $P_{OUT} = 3W$ ,  $R_L = 4\Omega$ )
- Low noise
  - :  $V_{NO} = 0.10mV_{rms}$  (Typ.)  
( $V_{CC} = 13.2V$ ,  $R_g = 0\Omega$ ,  $G_V = 34dB$ ,  $BW = 20\sim 20kHz$ )
- Built-in stand-by switch function (Pin②)
- Built-in muting function (Pin①, ⑤)
- Built-in AUX. amplifier from single input to 2 channels output (Pin⑩)
- Built-in junction temperature detection circuit (Pin⑭)
  - : Pin⑭ DC voltage rises at about  $+10mV/^\circ C$  in proportion to junction temperature.
- Built-in various protection circuit
  - : Thermal shut down, over voltage, out to GND, out to  $V_{CC}$ , out to out short
- Operating supply voltage
  - :  $V_{CC} (opr) = 9\sim 18V$

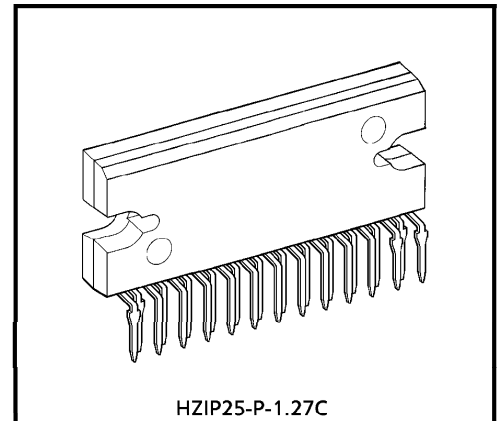

Weight : 9.8g (Typ.)

BLOCK DIAGRAM

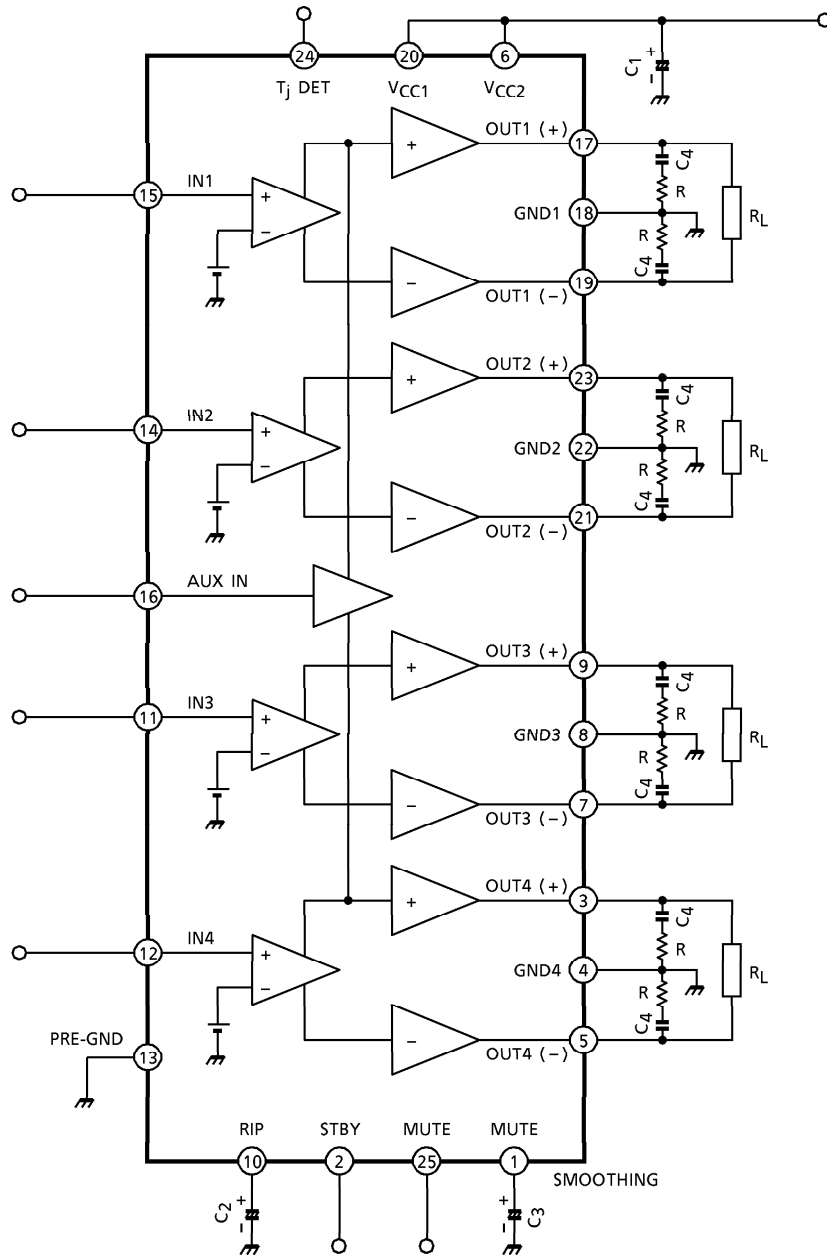

**CAUTION AND APPLICATION METHOD**

(Description is made only on the single channel.)

**1. Voltage gain adjustment**

This IC has no NF (negative feedback) terminals. Therefore, the voltage gain can't be adjusted, but it makes the device a space and total costs saver.

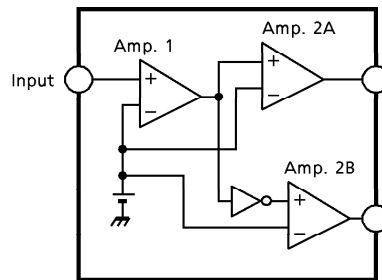

(Fig.1) Block diagram

The voltage gain of Amp. 1 :  $G_{V1} = 0\text{dB}$

The voltage gain of Amp. 2A, B :  $G_{V2} = 28\text{dB}$

The voltage gain of BLT Connection :  $G_V(\text{BTL}) = 6\text{dB}$

Therefore, the total voltage gain is decided by expression below.

$$G_V = G_{V1} + G_{V2} + G_V(\text{BTL}) = 0 + 28 + 6 = 34\text{dB}$$

**2. Stand-by SW function**

By means of controlling pin② (Stand-by terminal) to High and Low, the power supply can be set to ON and OFF. The threshold voltage of pin② is set at about 3V (Typ.), and the Power Supply current is about  $100\mu\text{A}$  (Typ.) at the stand-by state.

Control Voltage of pin② :  $V(\text{SB})$

STAND-BY	POWER	$V(\text{SB})$ (V)
ON	OFF	0~2
OFF	ON	3~ $V_{CC}$

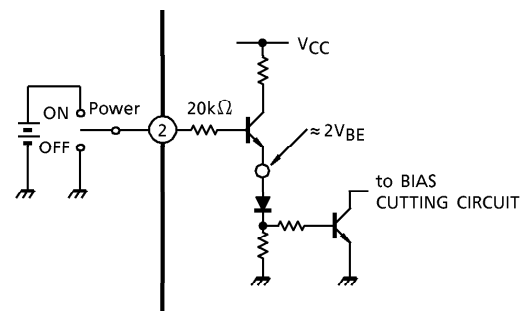

(Fig.2) With pin② set to High, Power is turned ON

**Adjustage of Stand-by SW**

- (1) Since  $V_{CC}$  can directly be controlled to ON or OFF by the microcomputer, the switching relay can be omitted.
- (2) Since the control current is microscopic, the switching relay of small current capacity is satisfactory for switching

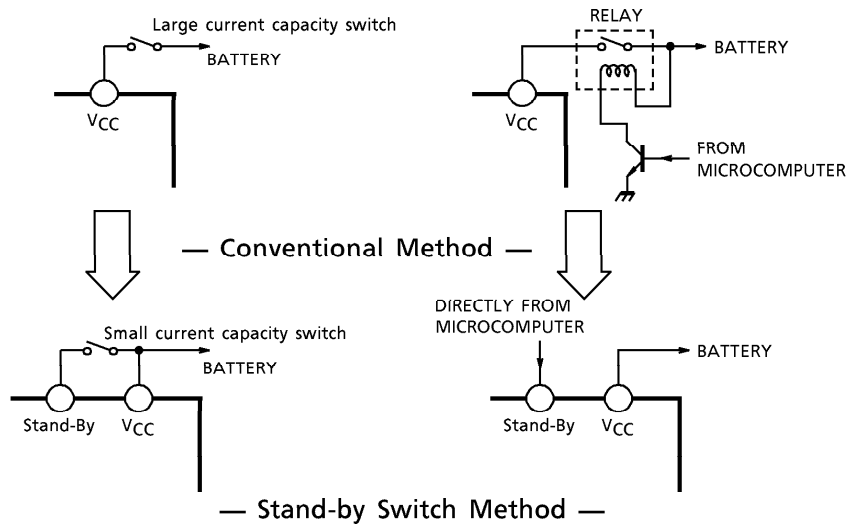

3. Preventive measure against oscillation

For preventing the oscillation, it is advisable to use C<sub>4</sub>, the condenser of polyester film having small characteristic fluctuation of the temperature and the frequency.

The resistance R to be series applied to C<sub>4</sub> is effective for phase correction of high frequency, and improves the oscillation allowance.

- (1) Capacity value and the kind of condenser
- (2) Layout of printed board

4. Junction temperature detecting pin<sup>④</sup>

Using temperature characteristic of a band gap circuit and in proportion to junction temperature, pin<sup>④</sup> DC voltage : V<sub>2</sub> rises at about +10mV/°C temperature characteristic. So, the relation between V<sub>2</sub> at T<sub>j</sub>=25°C and V<sub>2x</sub> at T<sub>j</sub>=x°C is decided by the following expression :

$$T (x^{\circ}\text{C}) = \frac{V_{2x} - V_2 (25^{\circ}\text{C})}{10\text{mV}/^{\circ}\text{C}} + 25 (^{\circ}\text{C})$$

In deciding a heat sink size, a junction temperature can be easily made clear by measuring voltage at this pin while a backside temperature of IC was so far measured using a thermocouple type thermometer.

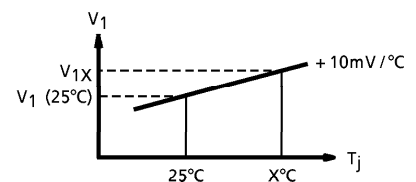

(Fig.3)

5. Muting function : pin①, pin②⑤

By means of controlling pin②⑤ (Mute control terminal) less than about 1.5V, it can make the IC muting condition as below. However, pin②⑤ must not be connected to a certain voltage, for example,  $V_{CC}$ ,  $V_{DD}$ ,  $V_{ref}$ ,...etc. In other words, pin②⑤ is inhibited to be pulled up, for instance fig.5 application.

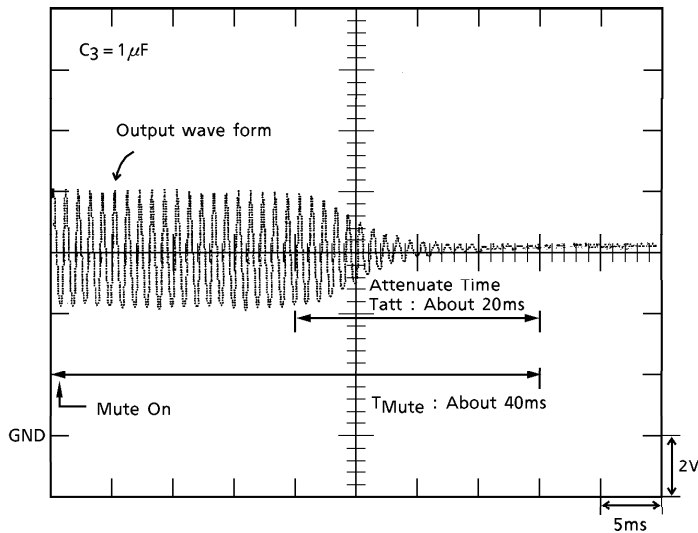

(Fig.4) Output wave form at Muting Condition

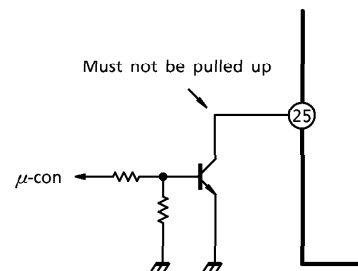

(Fig.5) Mute control

The attenuation by the muting function is 70dB (Typ.). This muting is very smooth attenuating by the time constant of pin① : smoothing.

Therefore, this function is suitable to the audio muting. The time for attenuation : Tatt is adjustable by changing the capacitance of C3. But the Tatt may influence the popping noise level. So, please decide the time of Tatt by testing on the units.

6. AUX. amplifier : pin⑩

The pin⑩ is for input terminal of AUX. amplifier.  
The total gain is 0dB by using of AUX. amplifier.

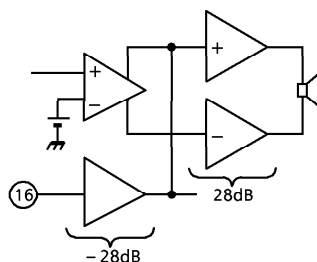

(Fig.6) AUX. amplifier

Therefore, the  $\mu$ -Con can directly drive the AUX. amplifier.

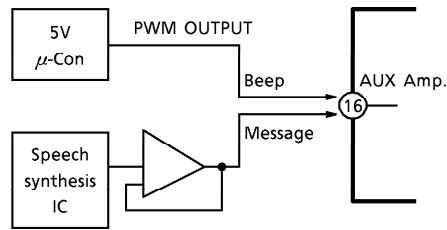

(Fig.7) The application of AUX. amplifier

The amplified signal from pin⑯ is out to the OUT1 and 4.

7. Cross talk

The cross talk characteristics of the IC is not good between OUT1 and 2, OUT3 and 4. So we recommend to use by below method.

OUT1, 2	L-ch (or R-ch)
OUT3, 4	R-ch (or L-ch)

And, please refer to below table in case of applying the AUX. IN because it is out to OUT 1 and 4.

ex)

OUT1	Front	L-ch (or R-ch)	AUX. OUT
OUT2	Rear		—
OUT3	Rear	R-ch (or L-ch)	—
OUT4	Front		AUX. OUT

## MAXIMUM RATING (Ta = 25°C)

CHARACTERISTIC	SYMBOL	RATING	UNIT
Peak Supply Voltage (0.2s)	V <sub>CC</sub> (surge)	50	V
DC Supply Voltage	V <sub>CC</sub> (DC)	25	V
Operating Supply Voltage	V <sub>CC</sub> (opr)	18	V
Output Current (peak)	I <sub>o</sub> (peak)	9	A
Power Dissipation	P <sub>D</sub> (*)	83	W
Operating Temperature	T <sub>opr</sub>	-40~85	°C
Storage Temperature	T <sub>stg</sub>	-55~150	°C

(\*) Package thermal resistance  $\theta_{j-T} = 1.5^{\circ}\text{C}/\text{W}$  (Typ.)  
(Ta = 25°C, with infinite heat sink)

ELECTRICAL CHARACTERISTICS (Unless otherwise specified V<sub>CC</sub> = 13.2V, f = 1kHz, R<sub>L</sub> = 4Ω, Ta = 25°C)

CHARACTERISTIC	SYMBOL	TEST CIR-CUIT	TEST CONDITION	MIN.	TYP.	MAX.	UNIT
Quiescent Current	I <sub>CCQ</sub>	—	V <sub>IN</sub> = 0	—	200	400	mA
Output Power	P <sub>OUT</sub> (MAX)	—	V <sub>CC</sub> = 13.7V, MAX power	—	30	—	W
	P <sub>OUT</sub> (1)	—	V <sub>CC</sub> = 14.4V, THD = 10%	—	21	—	
	P <sub>OUT</sub> (2)	—	THD = 10%	16	18	—	
Total Harmonic Distortion	THD	—	P <sub>OUT</sub> = 3W	—	0.02	0.2	%
Voltage Gain	G <sub>V</sub>	—	V <sub>OUT</sub> = 0.775V <sub>rms</sub> (0dBm)	32	34	36	dB
Voltage Gain Ratio	ΔG <sub>V</sub>	—	V <sub>OUT</sub> = 0.775V <sub>rms</sub> (0dBm)	-1.0	0	1.0	dB
Output Noise Voltage	V <sub>NO</sub> (1)	—	R <sub>g</sub> = 0Ω, DIN45405	—	0.12	—	mV <sub>rms</sub>
	V <sub>NO</sub> (2)	—	R <sub>g</sub> = 0Ω, BW = 20Hz~20kHz	—	0.10	0.35	mV <sub>rms</sub>
Ripple Rejection Ratio	R.R.	—	f <sub>rip</sub> = 100Hz, R <sub>g</sub> = 620Ω V <sub>rip</sub> = 0.775V <sub>rms</sub> (0dBm)	40	55	—	dB
Cross Talk	C.T.	—	R <sub>g</sub> = 620Ω, V <sub>OUT</sub> = 0.775V <sub>rms</sub> (0dBm)	—	75	—	dB
Output Offset Voltage	V <sub>OFFSET</sub>	—	—	-300	0	+300	mV
Input Resistance	R <sub>IN</sub>	—	—	—	30	—	kΩ
Stand-by Current	I <sub>SB</sub>	—	Stand-by condition	—	100	150	μA
Stand-by Control Voltage	V <sub>SB</sub> H	—	Power : on	3.0	—	V <sub>CC</sub>	V
	V <sub>SB</sub> L	—	Power : off	0	—	1.5	
Mute Control Voltage (*)	V <sub>M</sub> H	—	Mute : off	OPEN			V
	V <sub>M</sub> L	—	Mute : on	0	—	1.5	
Mute Attenuation	ATT M	—	Mute : on	—	70	—	dB

(\*) Muting function must be controlled by open and Low Logic.  
This means that the mute control terminal : pin⑤ must not be pulled up.

TEST CIRCUIT  
( $G_V = 34\text{dB}$ )

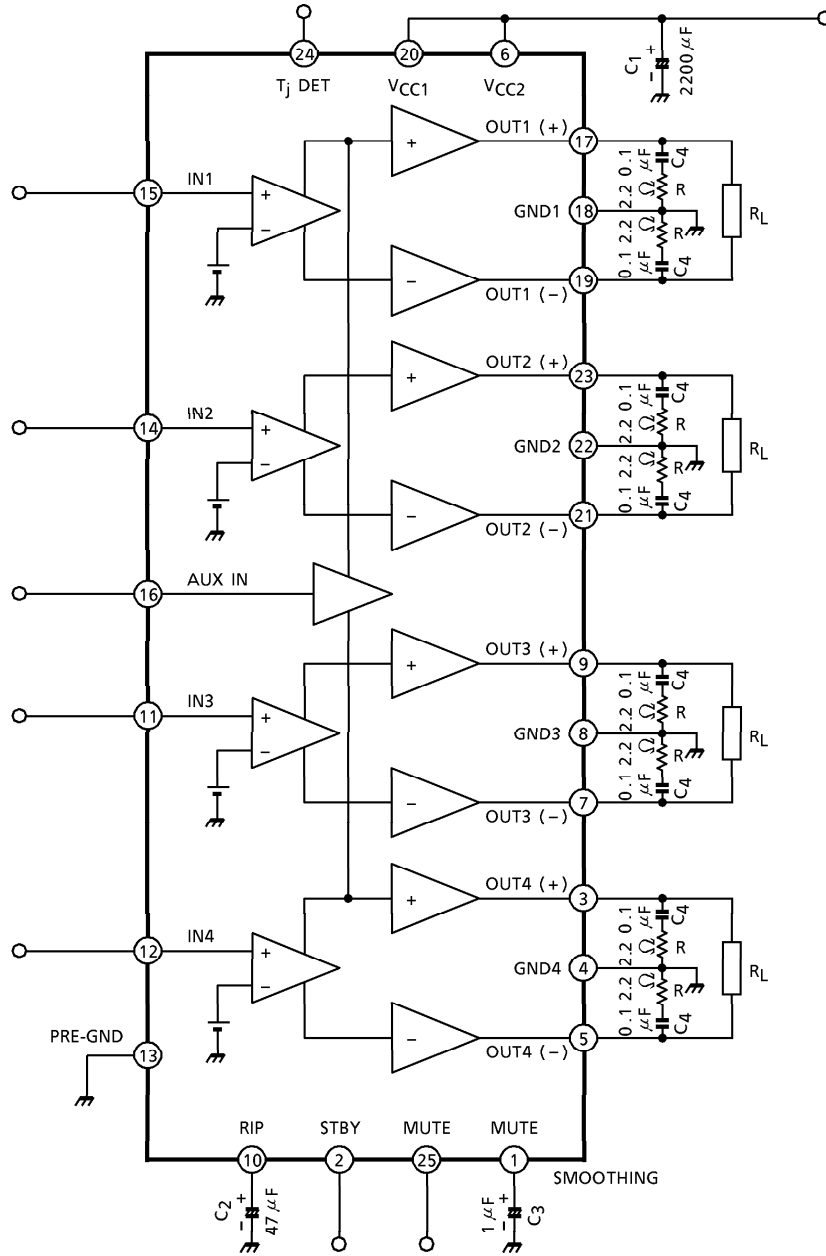



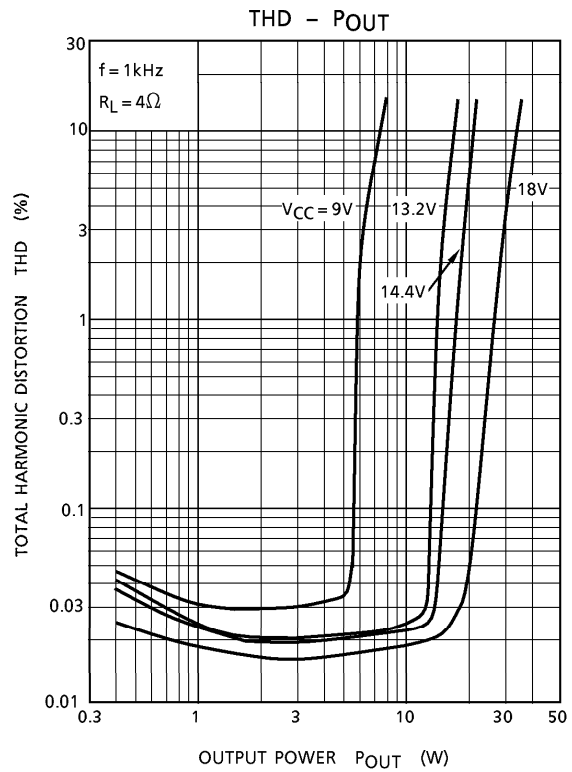
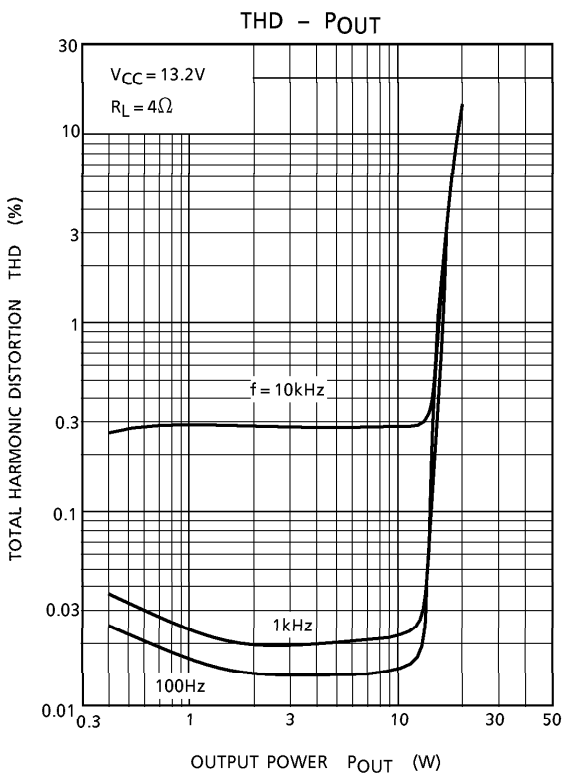
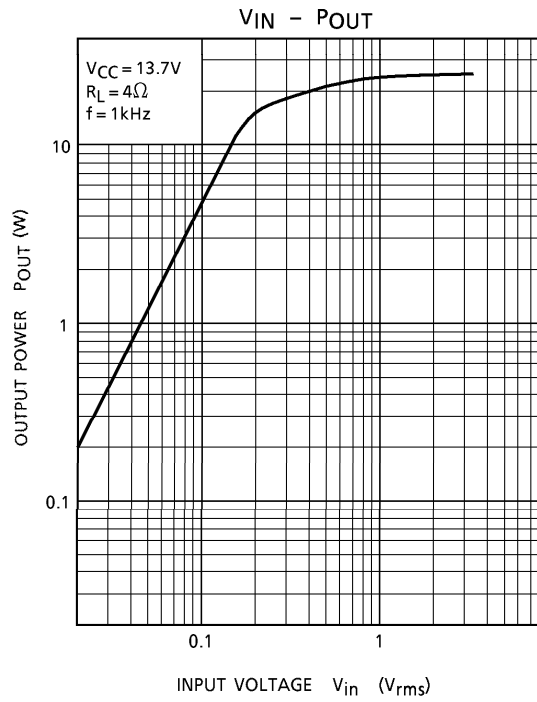
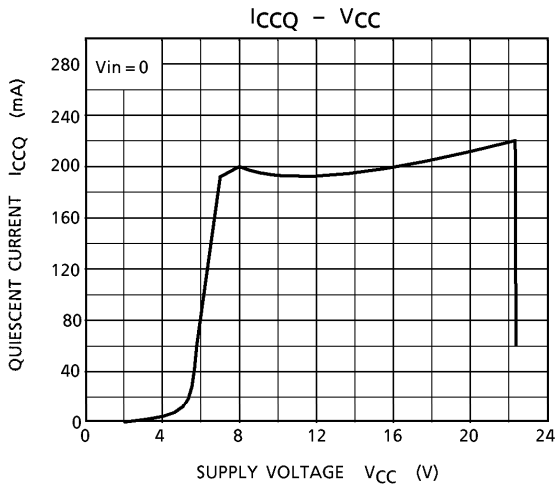

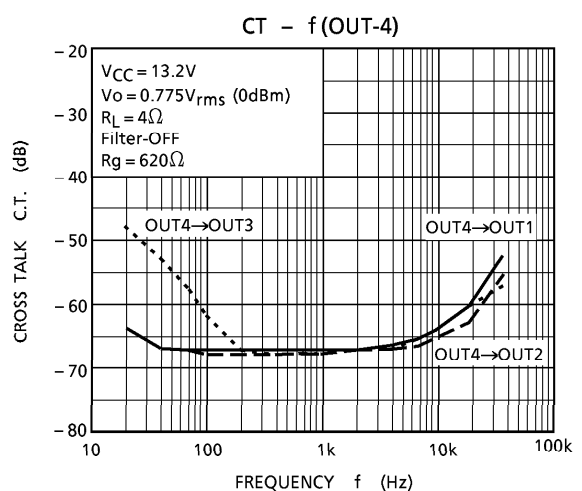
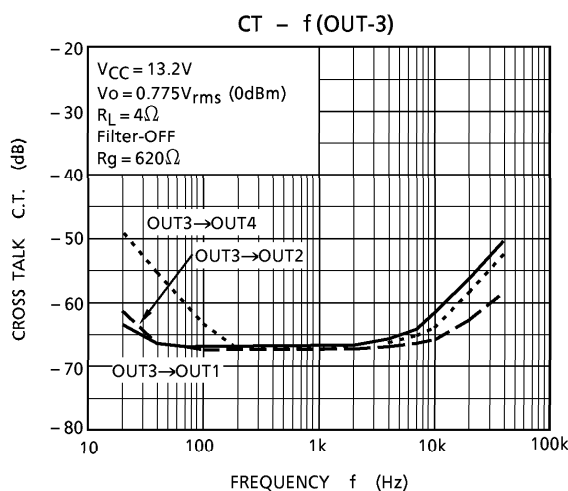
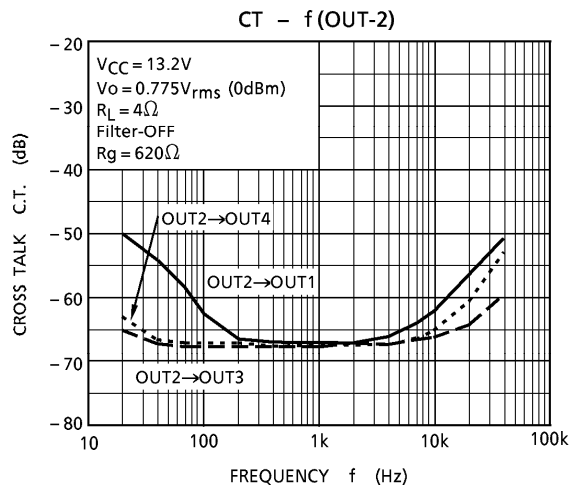
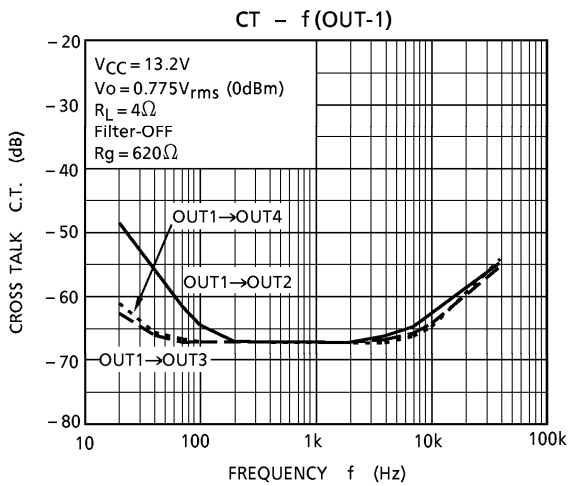
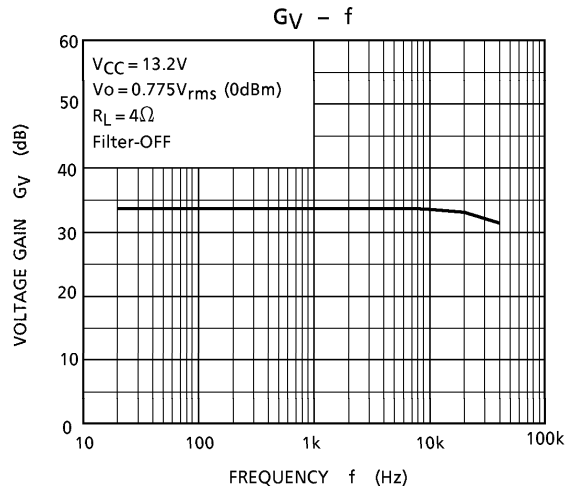
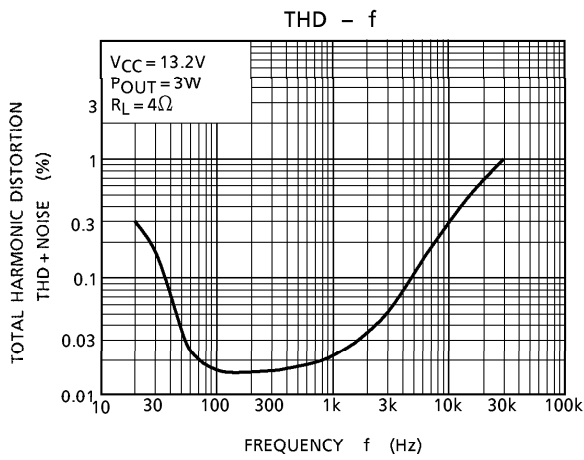

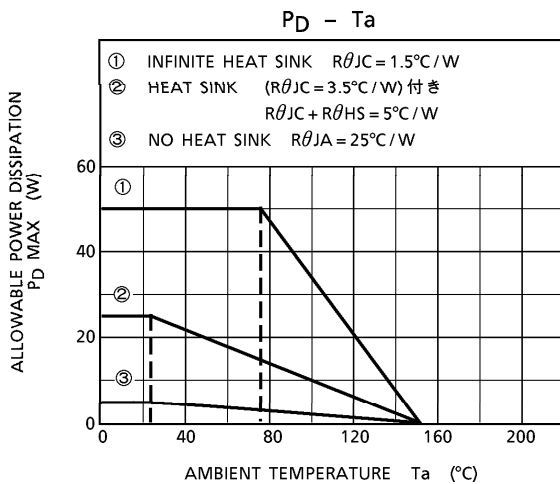
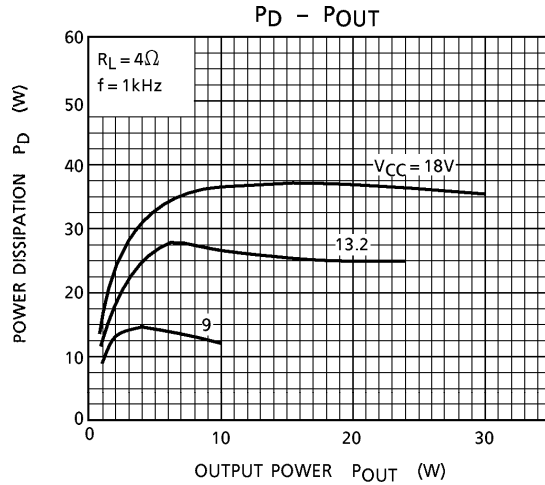
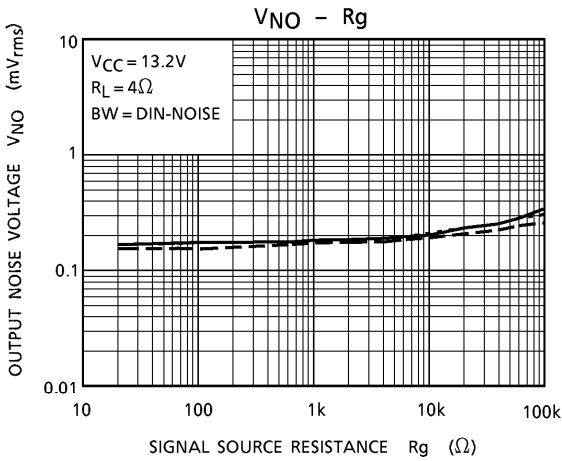
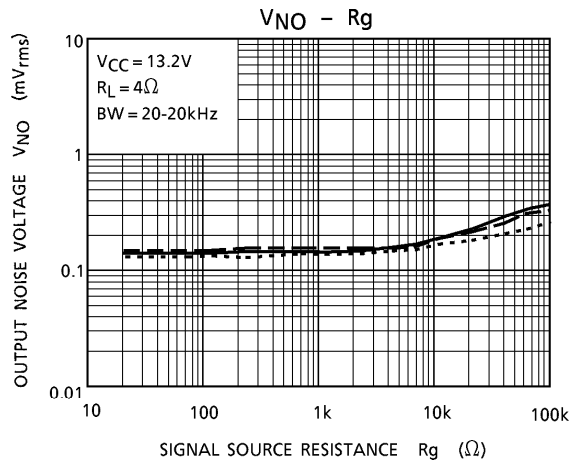
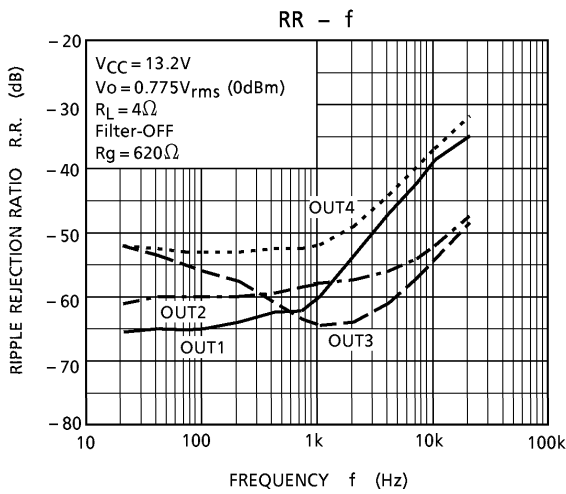

**PACKAGE DIMENSIONS**  
HZIP25-P-1.27C

Unit : mm

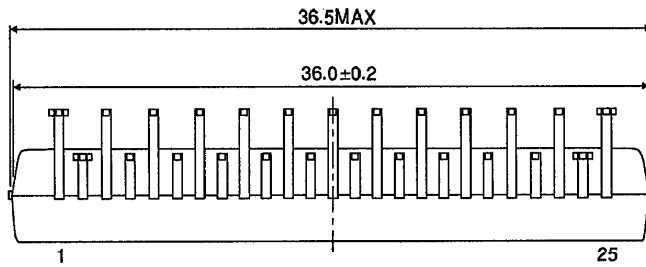
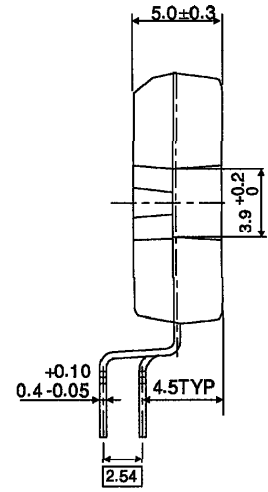
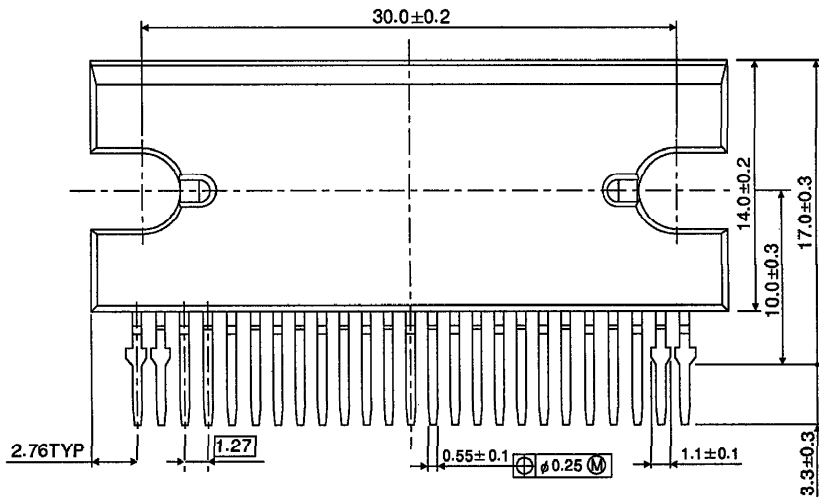

Weight : 9.8g (Typ.)

**RESTRICTIONS ON PRODUCT USE**

000707EBA

- TOSHIBA is continually working to improve the quality and reliability of its products. Nevertheless, semiconductor devices in general can malfunction or fail due to their inherent electrical sensitivity and vulnerability to physical stress. It is the responsibility of the buyer, when utilizing TOSHIBA products, to comply with the standards of safety in making a safe design for the entire system, and to avoid situations in which a malfunction or failure of such TOSHIBA products could cause loss of human life, bodily injury or damage to property. In developing your designs, please ensure that TOSHIBA products are used within specified operating ranges as set forth in the most recent TOSHIBA products specifications. Also, please keep in mind the precautions and conditions set forth in the "Handling Guide for Semiconductor Devices," or "TOSHIBA Semiconductor Reliability Handbook" etc..
- The TOSHIBA products listed in this document are intended for usage in general electronics applications (computer, personal equipment, office equipment, measuring equipment, industrial robotics, domestic appliances, etc.). These TOSHIBA products are neither intended nor warranted for usage in equipment that requires extraordinarily high quality and/or reliability or a malfunction or failure of which may cause loss of human life or bodily injury ("Unintended Usage"). Unintended Usage include atomic energy control instruments, airplane or spaceship instruments, transportation instruments, traffic signal instruments, combustion control instruments, medical instruments, all types of safety devices, etc.. Unintended Usage of TOSHIBA products listed in this document shall be made at the customer's own risk.
- The products described in this document are subject to the foreign exchange and foreign trade laws.
- The information contained herein is presented only as a guide for the applications of our products. No responsibility is assumed by TOSHIBA CORPORATION for any infringements of intellectual property or other rights of the third parties which may result from its use. No license is granted by implication or otherwise under any intellectual property or other rights of TOSHIBA CORPORATION or others.
- The information contained herein is subject to change without notice.