

0.6mm Pitch Board-to-Fine-Coaxial Cable Connectors

DF21 Series

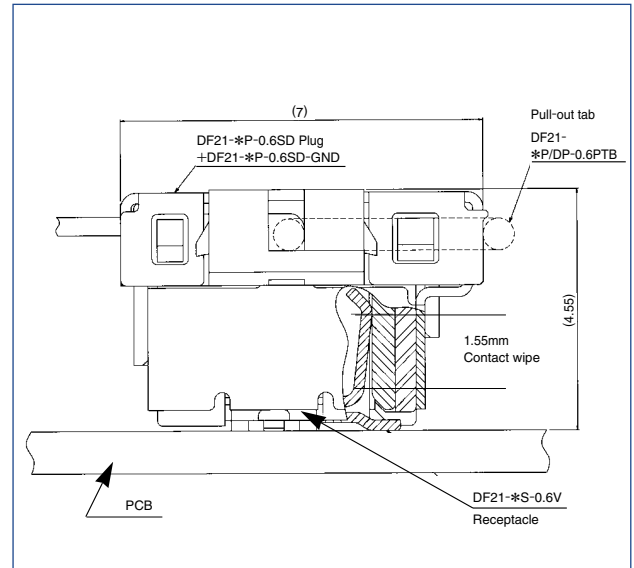
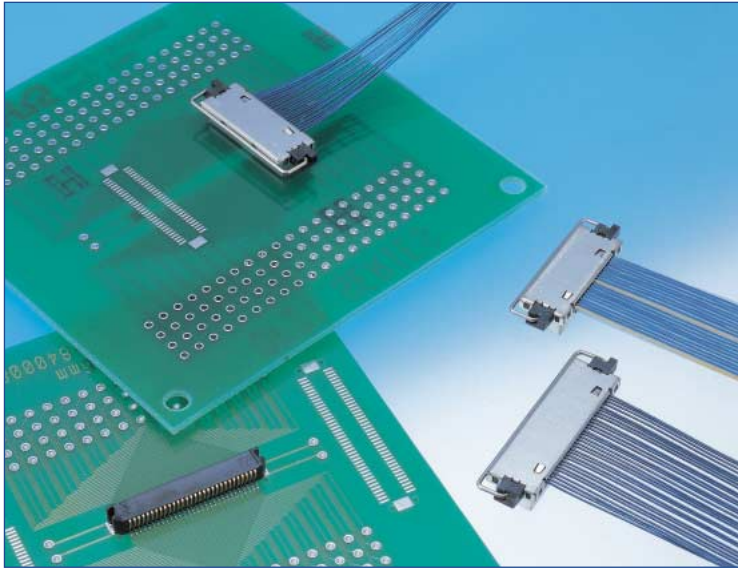

Features

1. High Interconnection Reliability

Effective contact mating length of 1.55 mm, innovative bellow style contact design, built-in interlocking feature of mated connectors assures high electrical and mechanical reliability, providing needed rigidity to resist excessive twisting.

Superior reliability of the termination of the fine coaxial cable is accomplished with batch soldering.

2. Shielded design

Metal shell encloses the connector and makes contact with all external conductors of the fine coaxial cable permitting reliable ground connection to the board side of mated assemblies.

3. Reliable mating/unmating

The connectors are self-align during mating.

Optional pull-out tab permits connection and disconnection in narrow spaces.

Polarized configuration prevents incorrect mating.

4. Board placement with Automatic Equipment.

The upper surface provides flat area for placement of embossed tape packaged connectors with vacuum nozzles of automatic equipment.

Applications

Notebook computers, liquid crystal displays (LCD), video and audio devices, medical instruments, portable devices and any other device requiring reliable connection and termination with fine pitch coaxial cable.

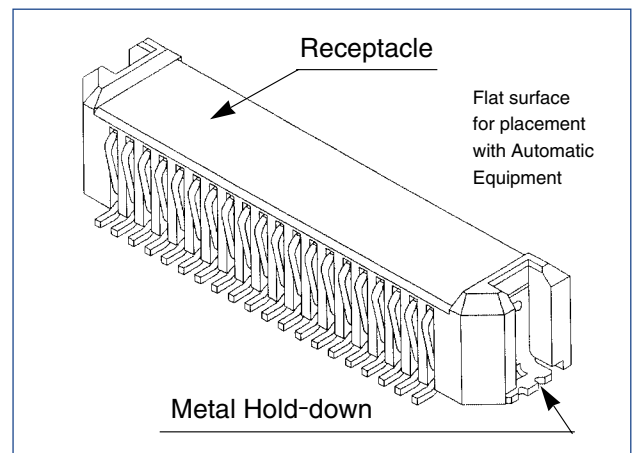

Product Specifications

Ratings	Current rating	Wire size	AWG #40: 0.3 A AWG #36: 0.5 A	Operating temperature range	-35°C to 85°C (Note 1)
				Operating humidity range	20% to 80%
				Storage temperature range	-10°C to 60°C (Note 2)
	Voltage rating	50 V AC	Storage humidity range	40% to 70% (Note 2)	

Item	Specifications	Condition
1. Insulation resistance	500M ohms min.	Measured at 100 V DC
2. Withstanding voltage	No flashover or insulation breakdown	Conduction of 150 V AC applied for 1 minute
3. Contact resistance	100m ohms max.	Measured at 100 mA
4. Vibration	No electrical discontinuity of 1μs or more.	Frequency of 10 to 55 Hz, single amplitude of 0.75 mm, in 3 directions, 2 hours
5. Humidity	Contact resistance of 100m ohms max., insulation resistance of 50 M ohms min.	Temperature of 40±2°C, humidity of 90% to 95%, left standing for 96 hours
6. Temperature cycle	Contact resistance of 100m ohms max., insulation resistance of 50 M ohms min.	(-55°C : 30minutes → 5 to 35°C : 2 to 3minutes → 85°C : 30minutes → 5 to 35°C : 2 to 3minutes) for 5 cycles
7. Durability	Contact resistance of 100m ohms max.	30 cycles (mating/unmating)
8. Resistance to Reflow heat	No melting of the resin parts that will affect performance	Reflow: at the recommended temperature profile, Solder: at a soldering iron temperature of 300°C for 3 seconds
9. Resistance to Soldering heat	No deformation of the insulator parts affecting performance.	Solder bond: Within 5 seconds at 270°C max., Within 30 seconds at 200°C min. Hand soldering: Soldering iron temperature 300°C, 3 seconds

Note 1: Includes temperature rise caused by current flow.

Note 2: The term "storage" refers to products stored for long period of time prior to mounting and use. Operating Temperature Range and Humidity range covers non- conducting condition of installed connectors in storage, shipment or during transportation.

Materials

Item	Part	Material	Finish	Remarks
Receptacles	Insulator	LCP	Black	UL94V-0
	Contacts	Phosphor bronze	Gold plating	—
	Metal fittings	Phosphor bronze	Solder plating	—
Plugs	Insulator	LCP	Black	UL94V-0
	Contacts	Phosphor bronze	Gold plating	—
	Metal shell	Phosphor bronze	Solder plating	—
Pull-out tab	Pull-out tab	Stainless steel	—	—

Ordering information

Receptacles/Plug

DF 21
*
P
0.6
SD
GND

①
②
③
④
⑤
⑥

① Series name : DF21	⑤ Termination section C : Crimping plug V : Straight SMT SD : Fine coaxial cable
② Number of contacts : 20, 30, 40	
③ Connector type S : Single-row receptacle P : Single-row plug	⑥ Plug mounting parts GND : Metal shell-required PTB : Pull-out tab-optional
④ Contact pitch : 0.6 mm	

Receptacles

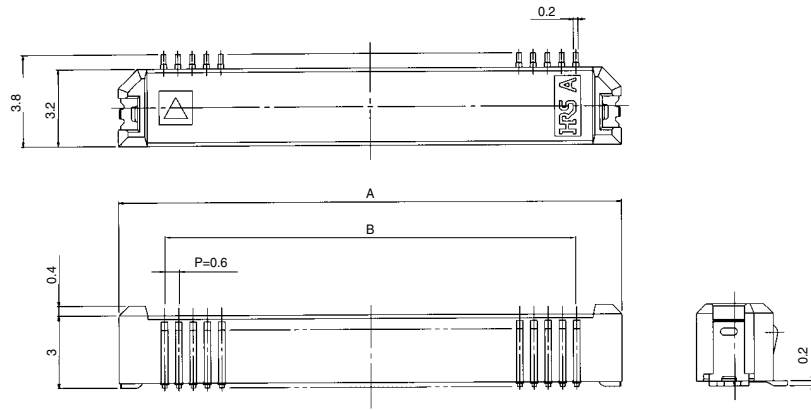
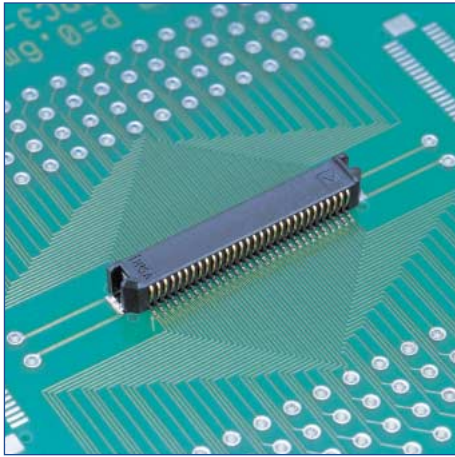

Embossed Carrier Tape Dimensions

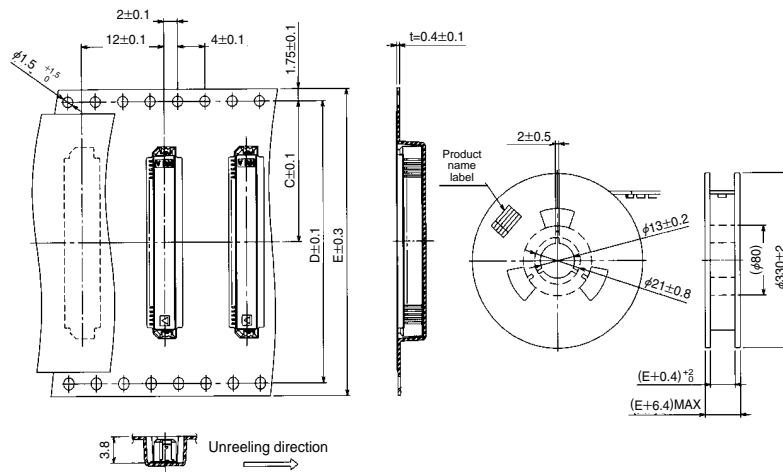

[Specifications number] - ** (* *)
 (51) : Embossed tape packaging (1,000 pieces per reel)

Unit: mm

Product No.	CL No.	Number of Contacts	A	B	C	D	E	F
DF21-20S-0.6V(51)	687-0001-5-51	20	15.2	11.4	11.5		24	12.6
DF21-30S-0.6V(51)	687-0003-0-51	30	21.2	17.4	14.2	28.4	32	18.6
DF21-40S-0.6V(51)	687-0002-8-51	40	27.2	23.4	20.2	40.4	44	24.6

(Note 1)

Note : One reel contains 1,000 pieces package unit. Please order by the package unit.

Recommended PCB mounting pattern

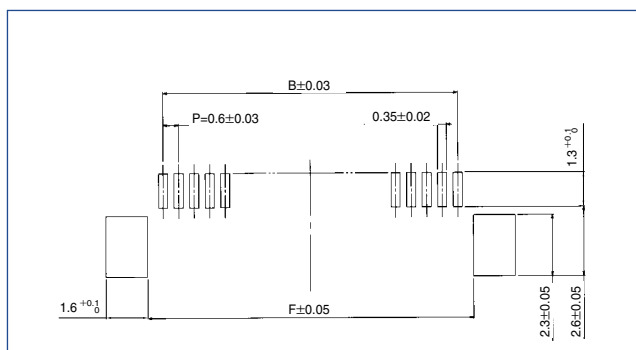

Plugs

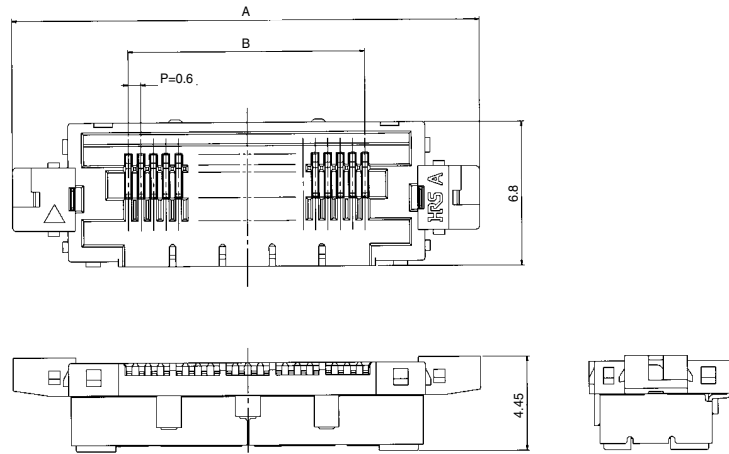

Unit: mm

Product No.	CL No.	Number of Contacts	A	B	C
DF21-20P-0.6SD	687-1500-0	20	22.5	11.4	15
DF21-30P-0.6SD	687-1502-6	30	28.5	17.4	21
DF21-40P-0.6SD	687-1501-3	40	34.5	23.4	27

Note 1: The 40 contact type is being planned.

Note 2: One package unit contains 100 pieces. Please order by the package unit.

Recommended Fine Coaxial Cable Preparation

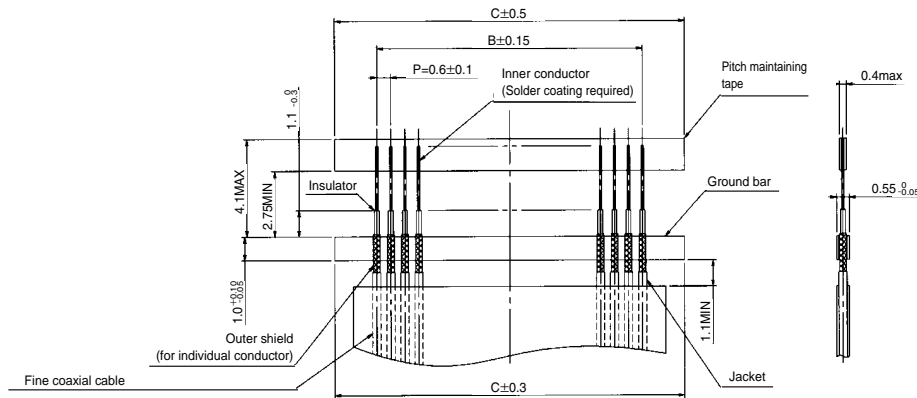

Note 1: The pitch maintaining tape can be left in place during the termination process. Use high quality tape.

Note 2: When using 2-conductor coaxial cable, some contact positions will not be usable.

Contact nearest Hirose sales office for recommendation on specific application.

Note 3: Contact Hirose for Termination Procedures.

■Metal shell-Required for assembly of the Plug

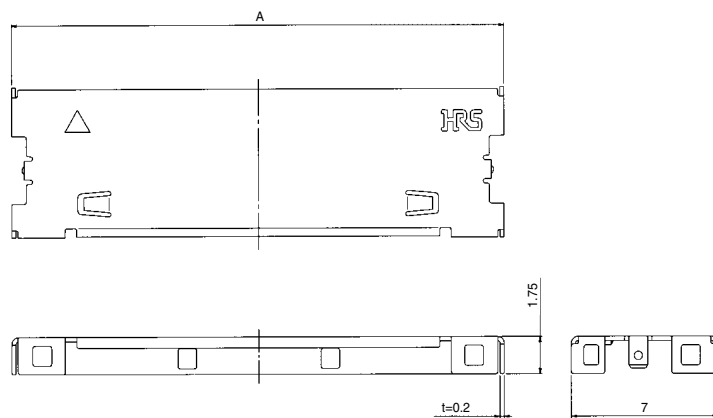

Unit: mm

Product No.	CL No.	Number of Contacts	A
DF21-20P-0.6SD-GND	687-2500-6	20	17.7
DF21-30P-0.6SD-GND	687-2502-1	30	23.7
DF21-40P-0.6SD-GND	687-2501-9	40	29.7

Note 1: One package unit contains 100 pieces. Please order by the package unit.

Note 2: The metal shell is an absolutely necessary part at the time of wiring.

■Pull-out Tab (Optional for Plug)

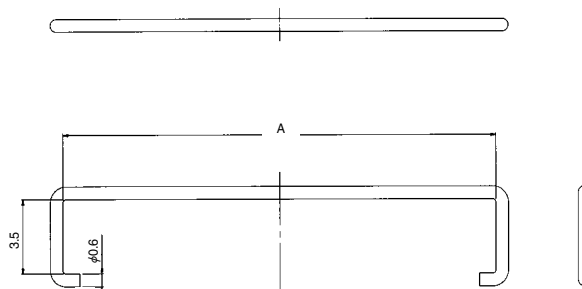

Unit: mm

Product No.	CL No.	Number of Contacts	A
DF21-20P/40DP-0.6PTB	687-1700-0	20	20.9
DF21-30P/60DP-0.6PTB	687-1701-2	30	26.9
DF21-40P/80DP-0.6PTB	687-1702-5	40	32.9

Note: One package unit contains 100 pieces. Please order by the package unit.

◆ Usage Recommendations

<p>1. Recommended Temperature Profile</p>	<div style="text-align: center;"> <table border="1" style="margin: 0 auto;"> <tr> <th style="text-align: center;">IR re-flow</th> </tr> <tr> <td style="padding: 2px;">Preheating : 150°C for 30 to 90 sec.</td> </tr> <tr> <td style="padding: 2px;">Soldering : 235°C±5°C for 10 sec max. 220°Cmin. for 10 to 20 sec.</td> </tr> </table> <p style="text-align: center;"> Note 1: Up to 2 cycles of reflow soldering are possible under the same conditions, provided that there is a return to normal temperature between the first and second cycle. Note 2: The temperature profile indicates the board surface temperature at the point of contacts with the connector terminals (for surface mounted plug assembly). </p> </div>	IR re-flow	Preheating : 150°C for 30 to 90 sec.	Soldering : 235°C±5°C for 10 sec max. 220°Cmin. for 10 to 20 sec.
IR re-flow				
Preheating : 150°C for 30 to 90 sec.				
Soldering : 235°C±5°C for 10 sec max. 220°Cmin. for 10 to 20 sec.				
<p>1. Recommended</p>	<p>Soldering temperature: 290°C ±10°C, Soldering time: within 2 sec.</p>			
<p>2. Receptacle Recommended Manual Soldering Conditions</p>	<p>Soldering temperature: 290°C ±10°C, soldering time: within 2 sec.</p>			
<p>3. Recommended Screen Thickness</p>	<p>0.15mm</p>			
<p>4. Board Warping</p>	<p>Maximum of 0.03 mm at the connector center section, with both ends of the connector as reference points.</p>			
<p>5. Cleaning Conditions</p>	<p>Refer to "Nylon Connector Use Handbook."</p>			
<p>6. Plug Recommended Soldering Conditions</p>	<p>260°C ±5°C within 5 sec, 200°C min. within 25 sec.</p>			
<p>7. Handling and use precautions</p>	<ul style="list-style-type: none"> ■ DO NOT mate/un-mate non-terminated plugs with non-mounted receptacles. This may lead to damage or deformation of the contacts. ■ DO NOT touch the exposed contacts of the receptacle with bare fingers. This may leave non-conductive film, cause corrosion or electrostatic discharge, affecting performance of the connectors or sensitive electronic components. ■ DO NOT apply flux to the contact terminals when hand soldering the receptacle to the board. Wicking of the flux into the electrical contact areas may lead to connection failures. 			