

October 1991  
Edition 1.0

FUJITSU

DATA SHEET

## MB88351

### R-2R TYPE 12-BIT D/A CONVERTER WITH OPERATIONAL AMPLIFIER OUTPUT BUFFERS

#### DESCRIPTION

The Fujitsu MB88351 is an R-2R type 12-bit resolution digital-to-analog converter (DAC), designed for interface with a wide range of general 4-bit and 8-bit microcontrollers including Fujitsu's MB88200 family, MB8850 family, and MB88500 family 4-bit single-chip microcontrollers.

The MB88351 has an 12-bit x 4-channel D/A converter with operational amplifier output buffers. Digital data are input serially by individual channel units. The loaded digital data are converted into analog DC voltages by the D/A converter in maximum 30  $\mu$ s settling time. Also, the MB88351 has operational amplifier output buffers. These operational amplifier output buffers are connected to each channel of the D/A converter, and provide high current drive capability. The MB88351 is suitable for electronic volumes and replacement for potentiometers for adjustment, in addition to normal D/A converter applications.

#### FEATURES

- Conversion method : R-2R resistor ladder
- 12-bit x 4-channel D/A converter with operational amplifier output buffers
- Max. 2.5MHz Serial data input
- Serial data output for cascade connection
- Max. 30  $\mu$ s DAC output settling time
- Max. +1.0/-1.0 mA analog output sink/source current
- Two separate power supply/ground lines for MCU interface block/operational amplifier output buffer block and D/A converter block
- Pin compatible with MB88353
- Low power dissipation : Typ. 1.5mW/channel
- Single +5V power supply
- Wide operating temperature range: -20°C to +85°C
- Silicon-gate CMOS process
- Three package options :
  - 16-pin plastic DIP (Suffix : -P), 16-pin plastic SOP (Suffix : -PF),
  - 20-pin plastic SSOP (Suffix : -PFV)

PRELIMINARY

MB88351-P

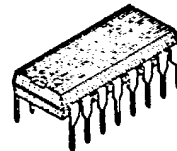

PLASTIC DIP  
(DIP-16P-M04)

MB88351-PF

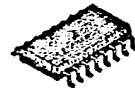

PLASTIC SOP  
(FPT-16P-M06)

MB88351-PFV



PLASTIC SSOP  
(FPT-20P-M03)

This device contains circuitry to protect the inputs against damage due to high static voltages or electric fields. However, it is advised that normal precautions be taken to avoid application of any voltage higher than maximum rated voltages to this high impedance circuit.

MB88351

Figure 1 Pin Assignment

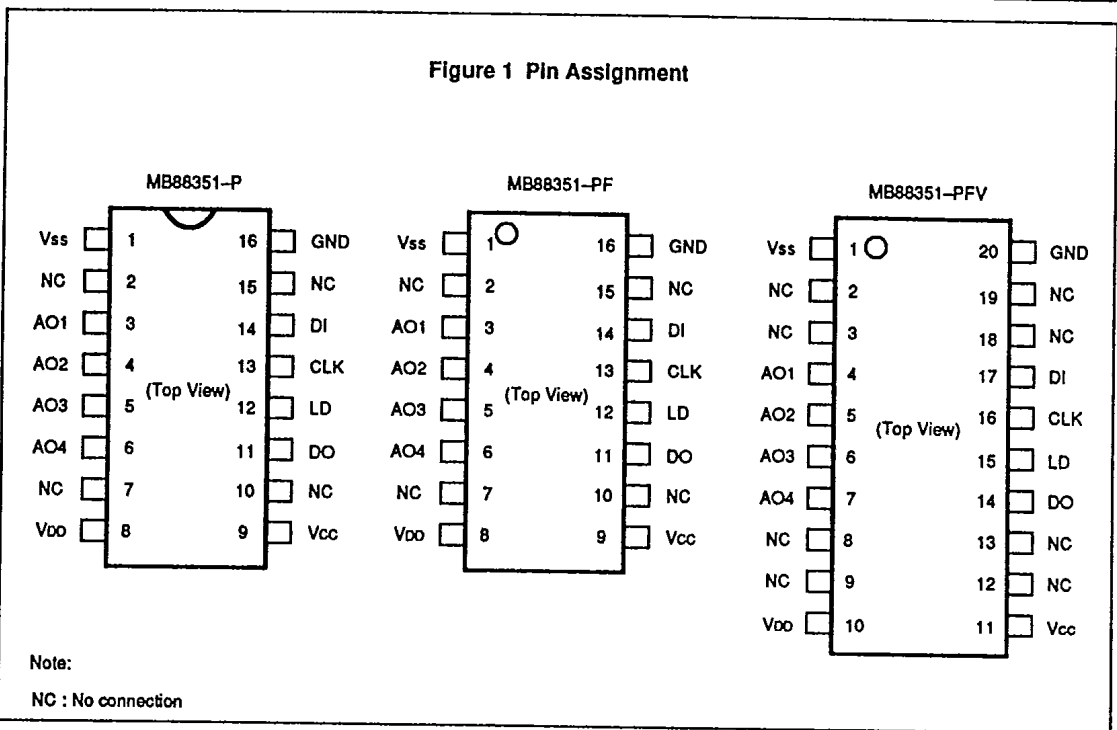
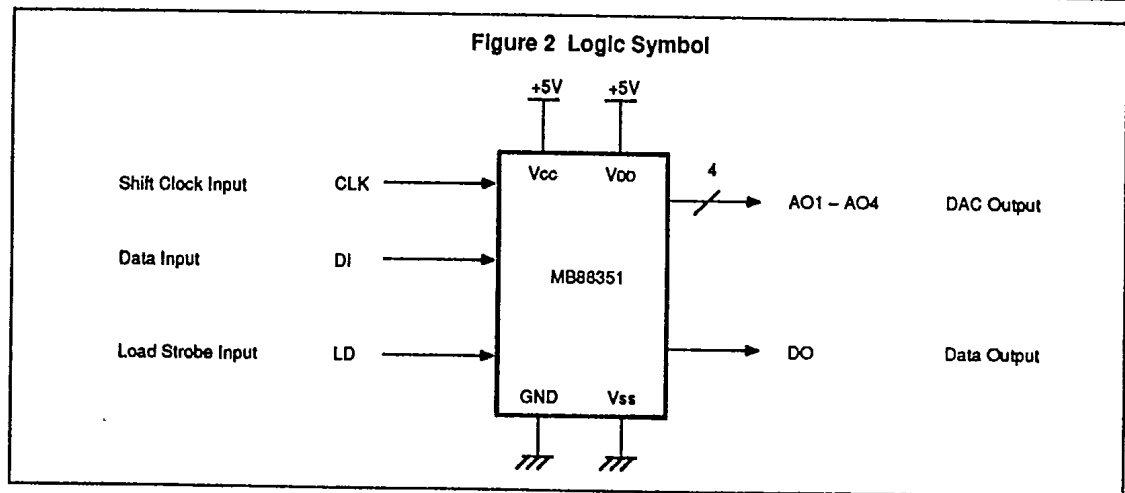
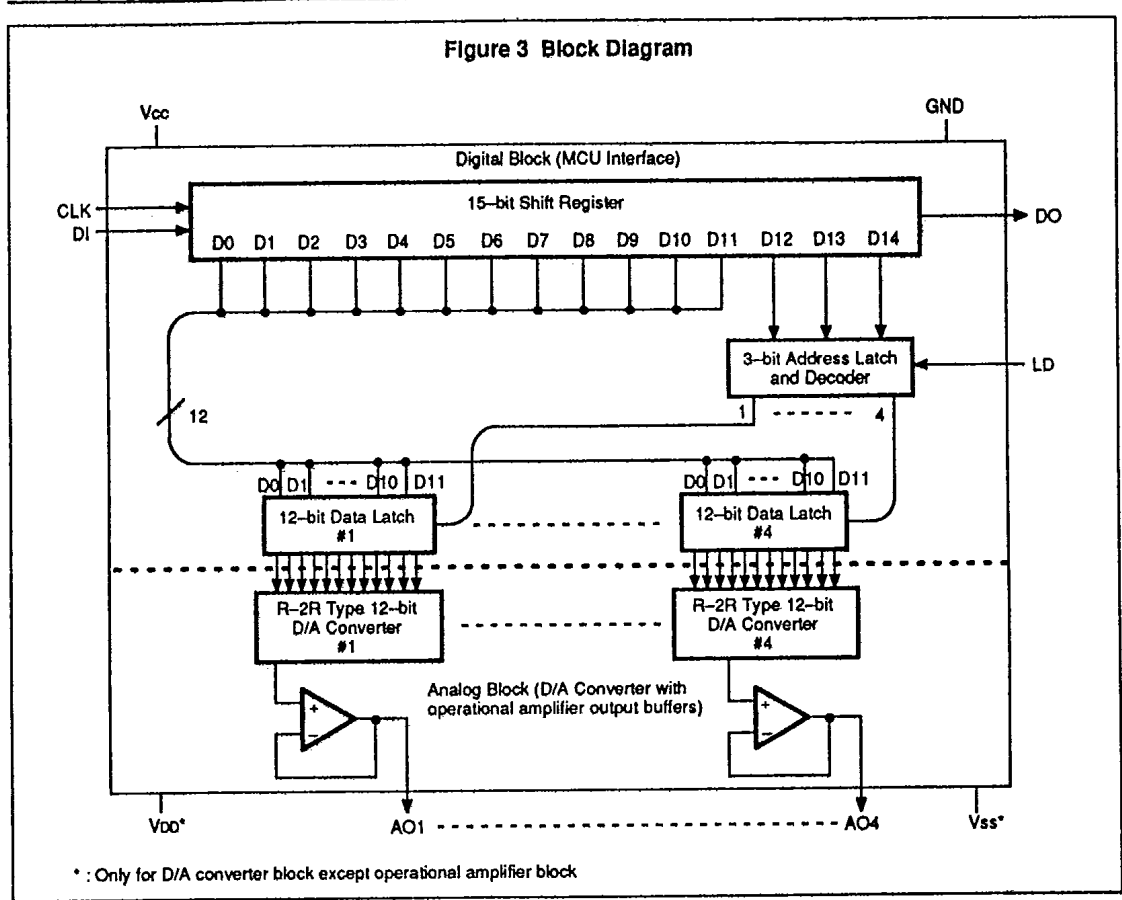

Figure 2 Logic Symbol





**MB88351**

**PIN DESCRIPTION**

Figure 1 and Table 1 show the pin assignment and pin description of the MB88351.

**Table 1 Pin Description**

Symbol	Pin No.		Type	Name & Function
	DIP/SOP	SSOP		
<b>Power Supply</b>				
Vcc	9	11	–	+5V DC power supply pin for the digital block (MCU interface) and operational amplifier output buffers.
GND	16	20	–	Ground pin for the digital block (MCU interface) and operational amplifier output buffers.
VDD	8	10	–	DC power supply pin for the analog block (D/A converter) except operational amplifier output buffers.
VSS	1	1	–	Ground pin for the analog block (D/A converter) except operational amplifier output buffers.
<b>Control Input</b>				
CLK	13	16	I	Shift clock input to the internal 15-bit shift register: At the rising edge of CLK data on the DI pin is shifted into the LSB of the shift register and contents of the shift register are shifted right (to the MSB).
LD	12	15	I	Load strobe input for a 15-bit address/data : A high level on the LD pin latches a 3-bit address (upper 3 bits: D14 to D12) of the internal 15-bit shift register into the internal address latch/decoder, and writes 12-bit data (lower 12 bits: D11 to D0) of the shift register into an internal data latch selected by the latched address.
<b>Data Input/Output</b>				
DI	14	17	I	Serial address/data input to the internal 15-bit shift register: The address/data format is that upper 3 bits (D14 to D12) indicate an address and lower 12 bits (D11 to D0) indicate data. The D14 (MSB) is the first-in bit and D0 (LSB) is the last-in bit.
DO	11	14	O	Serial address/data output from the internal 15-bit shift register: This is an output pin of the MSB bit data of the 15-bit shift register. This pin allows a cascade connection of the device.
<b>DAC Output</b>				
AO1 AO2 AO3 AO4	3 4 5 6	4 5 6 7	O	12-bit resolution D/A converter outputs : 4 channels (AO1 to AO4) of DAC outputs are provided. Each output channel has an operational amplifier output buffer for analog output data.
<b>Others</b>				
NC	2, 7, 10, 15	2, 3, 8, 9, 12, 13, 18, 19	–	No connection. They must be left open.

T-51-09-12

MB88351

## FUNCTIONAL DESCRIPTION

### OVERVIEW

The MB88351 is an R-2R resistor ladder type, 12-bit resolution digital-to-analog converter (DAC) device. The MB88351 has 4 channels of D/A converters with operational amplifier output buffers. 12-bit digital data are loaded into internal data latches by individual DAC channel units. The loaded digital data are converted into analog DC voltages through the internal D/A converter in max. 30  $\mu$ s settling time. And the analog DC voltages source/sink the output current through the operational amplifier output buffers. For cascade connection, a serial data output is provided.

### DEVICE CONFIGURATION

As illustrated in Figure 3 block diagram, the MB88351 device is composed by the digital block (MCU interface) and analog block (D/A converter with operational amplifier output buffers). The digital block consists of a 15-bit shift register, a 3-bit address latch/decoder, and 4 channels of 12-bit data latches. The analog block includes 4 channels of 12-bit D/A converters with operational amplifier output buffers connecting to the data latches. For electrically stable operation the power supply and ground lines are separate between the digital block (MCU interface) and operational amplifier output buffers, and analog block except operational amplifier output buffers.

### DEVICE OPERATION

Figure 4 shows the input/output timing. A 15-bit address/data is serially input into the shift register through the DI pin synchronously with the rising edge of CLK. The format of the shift register is shown in Figure 5. The lower 12 bits (D11 to D0) are data bits to be converted, and the upper 3 bits are address bits (D14 to D12) to select a data latch to be written. A high level on the LD pin loads the address latch/decoder with the 3-bit address to select a data latch, and writes the 12-bit data into a selected data latch. Figure 6 shows the data latch address map, and Table 2 lists the address decoding. 12-bit data written into individual data latches are converted into analog DC voltages, dividing the supply voltage  $[V_{DD}-V_{SS}]$  through R-2R resistor ladders of D/A converters. The operational amplifier output buffers at individual D/A converter outputs can source up to 1 mA of the output current. Figure 7 shows a configuration of the R-2R resistor ladder D/A converter with operational amplifier, and Table 3 lists the analog DC voltages corresponding to each digital data.

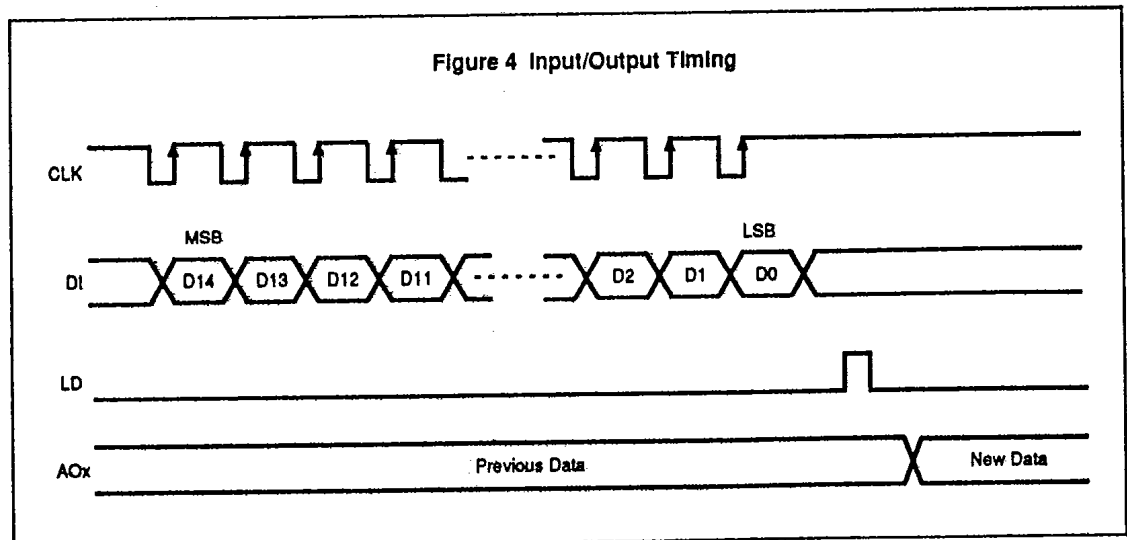

T-51-09-12

MB88351

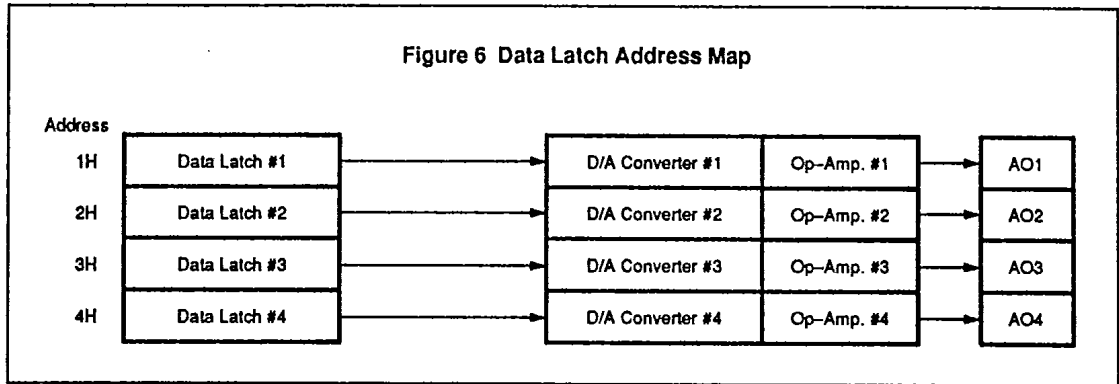
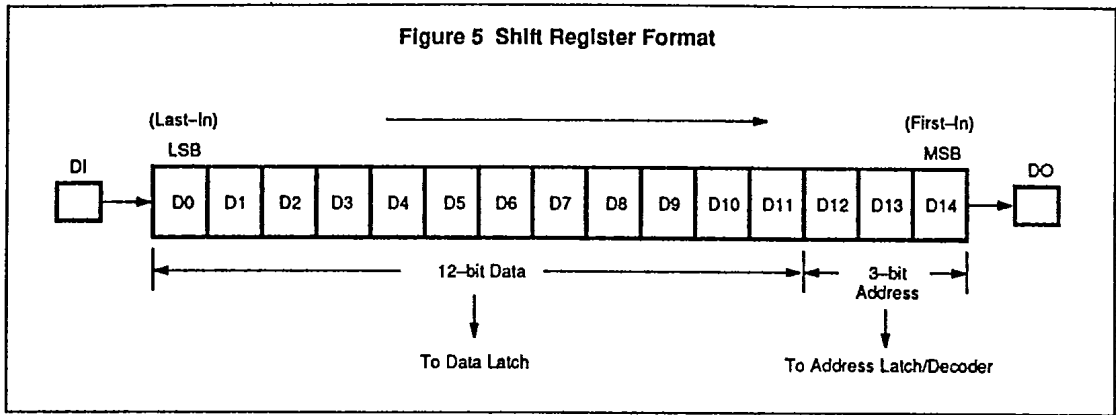

T-51-09-12

MB88351

Figure 7 Configuration of R-2R Resistor Ladder D/A Converter with Operational Amplifier Output Buffer

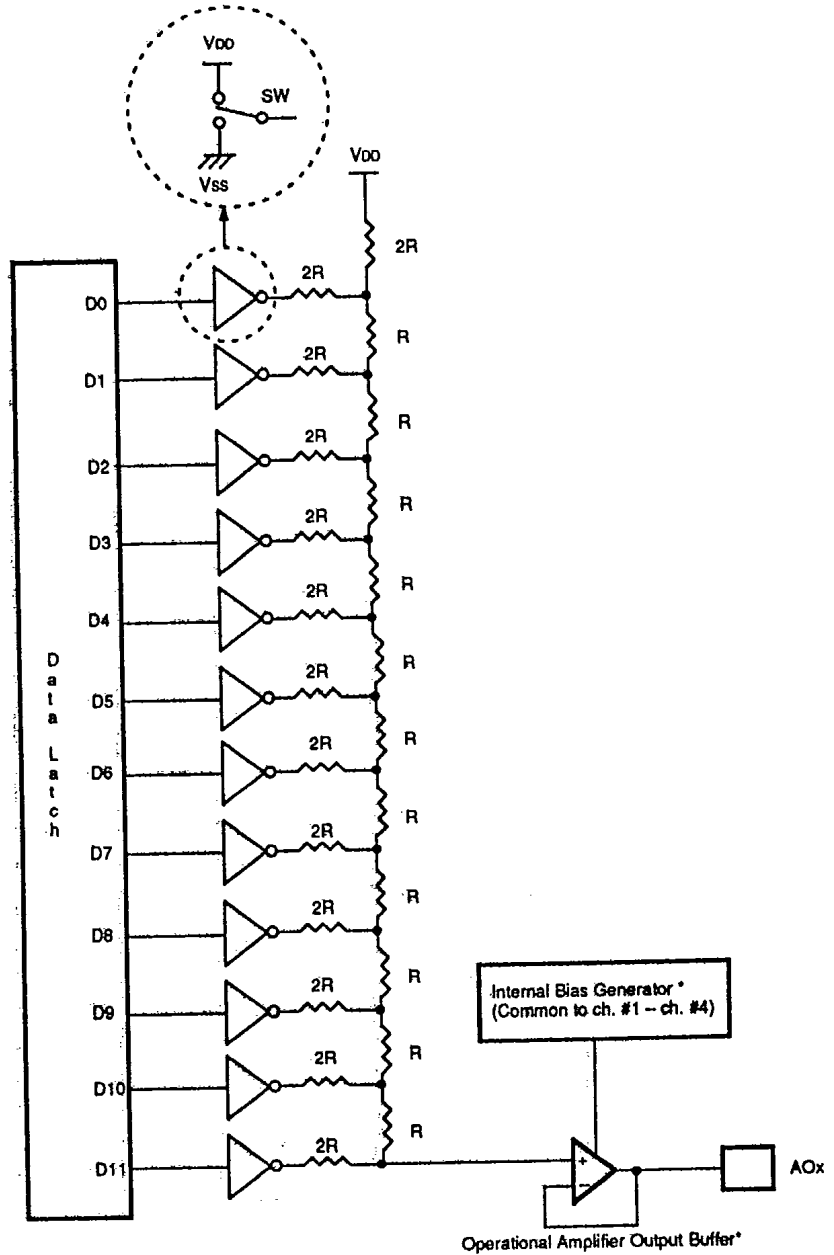

\* : Powered/grounded by the Vcc and GND pins.

T-51-09-12

MB88351

Table 2 Address Decoding

Address			Data Latch Selected
D12	D13	D14	MB88351
0	0	0	Deselected
0	0	1	Data Latch #1
0	1	0	Data Latch #2
0	1	1	Data Latch #3
1	0	0	Data Latch #4
1	0	1	Deselected
1	1	0	Deselected
1	1	1	Deselected

Table 3 Data Conversion

Data												DAC Output Level
D11	D10	D9	D8	D7	D6	D5	D4	D3	D2	D1	D0	AOx
0	0	0	0	0	0	0	0	0	0	0	0	= Vss
0	0	0	0	0	0	0	0	0	0	0	1	$= (V_{DD} - V_{SS}) \times 1/4095 + V_{SS}$
0	0	0	0	0	0	0	0	0	0	1	0	$= (V_{DD} - V_{SS}) \times 2/4095 + V_{SS}$
0	0	0	0	0	0	0	0	0	0	1	1	$= (V_{DD} - V_{SS}) \times 3/4095 + V_{SS}$
⋮	⋮	⋮	⋮	⋮	⋮	⋮	⋮	⋮	⋮	⋮	⋮	⋮
1	1	1	1	1	1	1	1	1	1	0	0	$= (V_{DD} - V_{SS}) \times 4092/4095 + V_{SS}$
1	1	1	1	1	1	1	1	1	1	0	1	$= (V_{DD} - V_{SS}) \times 4093/4095 + V_{SS}$
1	1	1	1	1	1	1	1	1	1	1	0	$= (V_{DD} - V_{SS}) \times 4094/4095 + V_{SS}$
1	1	1	1	1	1	1	1	1	1	1	1	= VDD



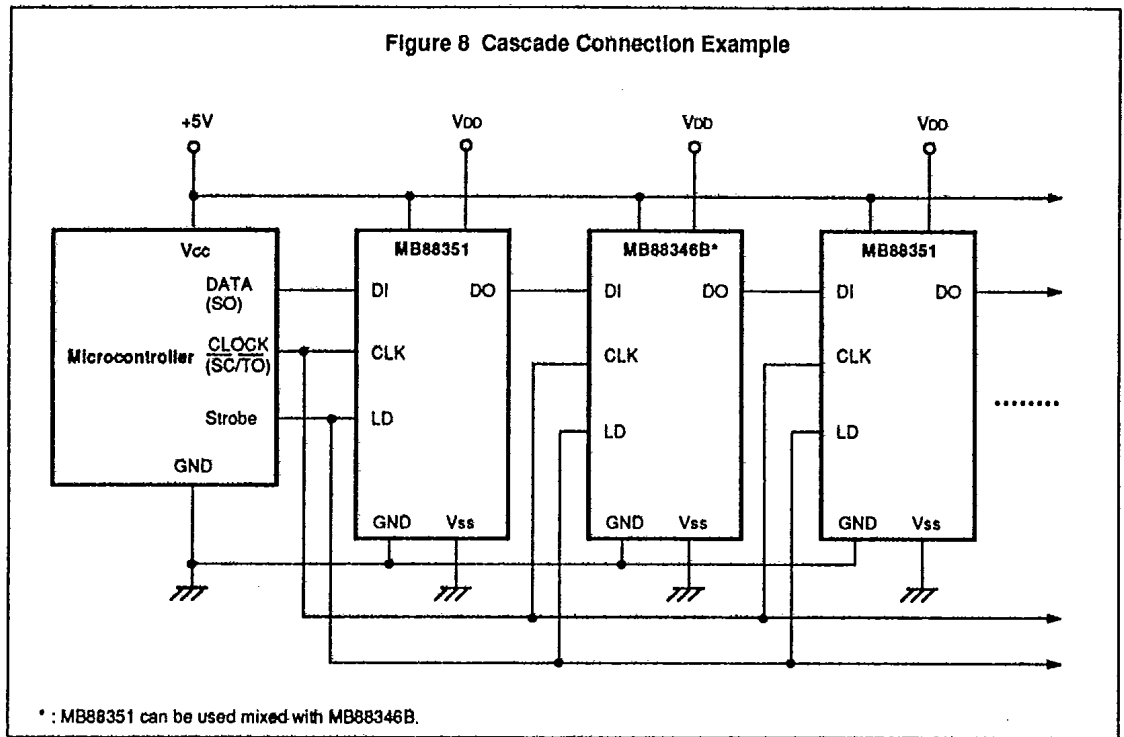

T-51-09-12

**MB88351**

**APPLICATION DESCRIPTION**

The MB88351 is suitable for electronic volumes and replacement for adjustment potentiometers, in addition to normal D/A converter applications. Figure 9 illustrates application example for a gain control.

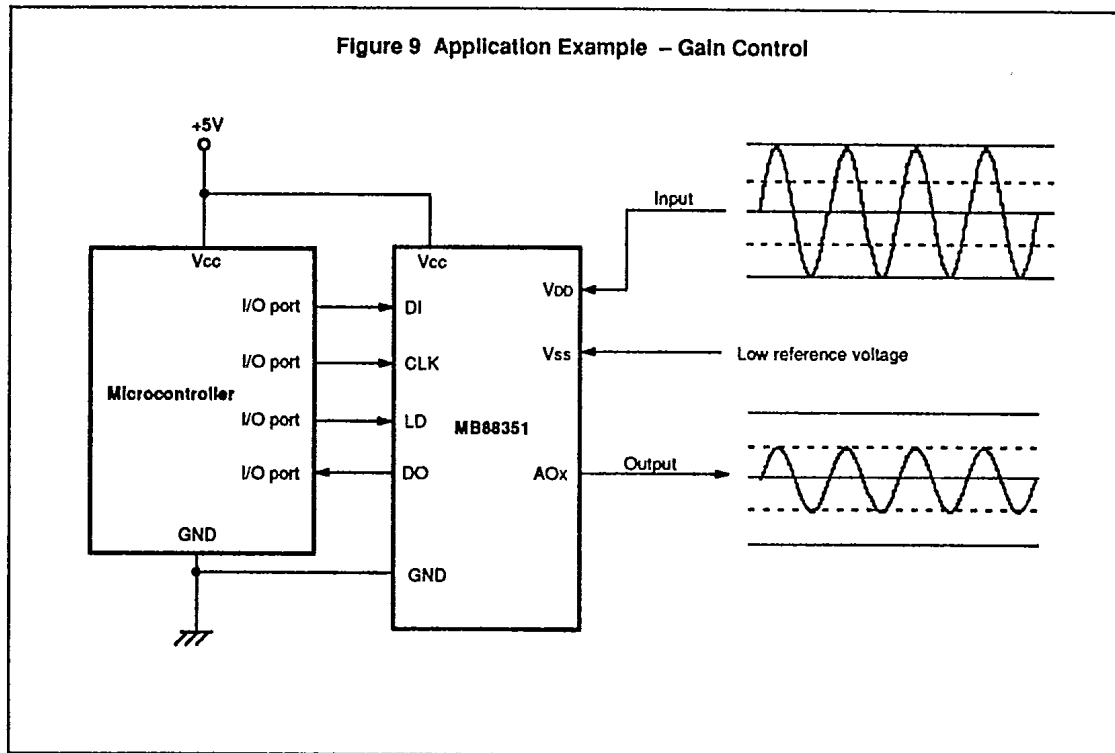

T-51-09-12

MB88351

## ELECTRICAL CHARACTERISTICS

### ABSOLUTE MAXIMUM RATINGS (See NOTE)

Parameter	Symbol	Rating			Unit	Condition
		Min	Typ	Max		
Supply Voltage	Vcc	-0.3		7.0	V	Ta = +25°C GND = 0 V V <sub>DD</sub> ≤ V <sub>CC</sub> .
	V <sub>DD</sub>	-0.3		7.0	V	
Input Voltage	V <sub>IN</sub>	-0.3		V <sub>CC</sub> +0.3	V	Ta = 25°C GND = 0 V Should not exceed V <sub>CC</sub> + 0.3V
Output Voltage	V <sub>OUT</sub>	-0.3		V <sub>CC</sub> +0.3	V	
Power Dissipation	P <sub>D</sub>			250	mW	
Operating Ambient Temperature	T <sub>A</sub>	-20		+85	°C	
Storage Temperature	T <sub>STG</sub>	-55		+150	°C	

NOTE : Permanent device damage may occur if the above ABSOLUTE MAXIMUM RATINGS are exceeded. Functional operation should be restricted to the conditions as detailed in the operational sections of this data sheet. Exposure to absolute maximum rating conditions for extended periods may affect device reliability.

### RECOMMENDED OPERATING CONDITIONS

Parameter	Symbol	Value			Unit	Condition
		Min	Typ	Max		
Supply Voltage (for MCU Interface/ Op.-Amp. Block)	V <sub>CC</sub>	4.5	5.0	5.5	V	V <sub>CC</sub> ≥ V <sub>DD</sub>
	GND		0		V	
Supply Voltage (for Analog Block*)	V <sub>DD</sub>	2.0		V <sub>CC</sub>	V	V <sub>CC</sub> ≥ V <sub>DD</sub> , V <sub>DD</sub> - V <sub>SS</sub> ≥ 2.0V
	V <sub>SS</sub>	GND		V <sub>CC</sub> - 2.0	V	
Analog Output Source Current	I <sub>AL1</sub>			-1.0	mA	
Analog Output Sink Current	I <sub>AL2</sub>			+1.0	mA	
Analog Output Load Capacitance for oscillation limit	C <sub>AL</sub>			1.0	μF	
Operating Ambient Temperature	T <sub>A</sub>	-20		+85	°C	

\* : Except operational amplifier output buffer block

T-51-09-12

## MB88351

## DC CHARACTERISTICS

(Recommended operating conditions unless otherwise noted.)

## Digital Block (MCU Interface)

Parameter	Symbol	Value			Unit	Condition
		Min	Typ.	Max		
Active Supply Current (Vcc) *	I <sub>CC</sub>		1.0	2.5	mA	CLK = 1MHz, Unloaded
Input Leakage Current (CLK, DI, and LD)	I <sub>ILK</sub>	-10		+10	μA	V <sub>IN</sub> = 0 to V <sub>CC</sub>
Input Low Voltage (CLK, DI, and LD)	V <sub>IL</sub>			0.2•V <sub>CC</sub>	V	
Input High Voltage (CLK, DI, and LD)	V <sub>IH</sub>	0.8•V <sub>CC</sub>			V	
Output Low Voltage (DO)	V <sub>OL</sub>			0.4	V	I <sub>OL</sub> = 2.5 mA
Output High Voltage (DO)	V <sub>OH</sub>	V <sub>CC</sub> -0.4			V	I <sub>OH</sub> = -400 μA

\* : Including the supply current to the operational amplifier block

## Analog Block (D/A Converters with Operational Amplifier Output Buffers)

Parameter	Symbol	Value			Unit	Condition
		Min	Typ	Max		
Supply Current (V <sub>DD</sub> ) **	I <sub>DD</sub>		0.1	0.3	mA	Unloaded
Analog Supply Voltage (V <sub>DD</sub> , V <sub>SS</sub> )	V <sub>DD</sub>	2.0		V <sub>CC</sub>	V	V <sub>DD</sub> -V <sub>SS</sub> ≥2.0V
	V <sub>SS</sub>	GND		V <sub>CC</sub> -2.0	V	
Resolution (AOx)	Res		12		bit	
Monotonicity (AOx)	Rem		10		bit	Unloaded
Offset Error (AOx)***	E <sub>O</sub>	-0.1	0	+0.1	V	Unloaded
Nonlinearity Error (AOx)	ENL	-8.0	0	+8.0	LSB	Unloaded, V <sub>DD</sub> ≤V <sub>CC</sub> -0.1V, V <sub>SS</sub> ≥0.1V See Figure 10.

\*\* : Excluding the supply current to the operational amplifier block

T-57-09-12

MB88351

Analog Block (D/A Converters with Operational Amplifier Output Buffers) – Continued

Parameter	Symbol	Value			Unit	Condition
		Min	Typ	Max		
Min. Analog Output Voltage 1 (AOx)	VAOL1	GND		GND+0.1	V	Unloaded, Vss = 0V, Digital data=#000
Min. Analog Output Voltage 2 (AOx)	VAOL2	GND-0.1	GND	GND+0.1	V	VDD=VCC=5.0V, Vss=GND=0V, IAL1=-400μA, Digital data=#000
Min. Analog Output Voltage 3 (AOx)	VAOL3	GND-0.3	GND	GND+0.3	V	VDD=VCC=5.0V, Vss=GND=0V, IAL1=-1.0mA, Digital data=#000
Min. Analog Output Voltage 4 (AOx)	VAOL4	GND		GND+0.1	V	VDD=VCC=5.0V, Vss=GND=0V, IAL2=+400μA, Digital data=#000
Min. Analog Output Voltage 5 (AOx)	VAOL5	GND		GND+0.3	V	VDD=VCC=5.0V, Vss=GND=0V, IAL2=+1.0mA, Digital data=#000
Max. Analog Output Voltage 1 (AOx)	VAOH1	VCC-0.1		VCC	V	Unloaded, VDO = VCC, Digital data=#FFF
Max. Analog Output Voltage 2 (AOx)	VAOH2	VCC-0.1		VCC	V	VDD=VCC=5.0V, Vss=GND=0V, IAL1=-400μA, Digital data=#FFF
Max. Analog Output Voltage 3 (AOx)	VAOH3	VCC-0.3		VCC	V	VDD=VCC=5.0V, Vss=GND=0V, IAL1=-1.0mA, Digital data=#FFF
Max. Analog Output Voltage 4 (AOx)	VAOH4	VCC-0.1	VCC	VCC+0.1	V	VDD=VCC=5.0V, Vss=GND=0V, IAL2=+400μA, Digital data=#FFF
Max. Analog Output Voltage 5 (AOx)	VAOH5	VCC-0.3	VCC	VCC+0.3	V	VDD=VCC=5.0V, Vss=GND=0V, IAL2=+1.0mA, Digital data=#FFF

\*\* : Excluding the supply current to the operational amplifier block

Figure 10 Definition of Nonlinearity Error

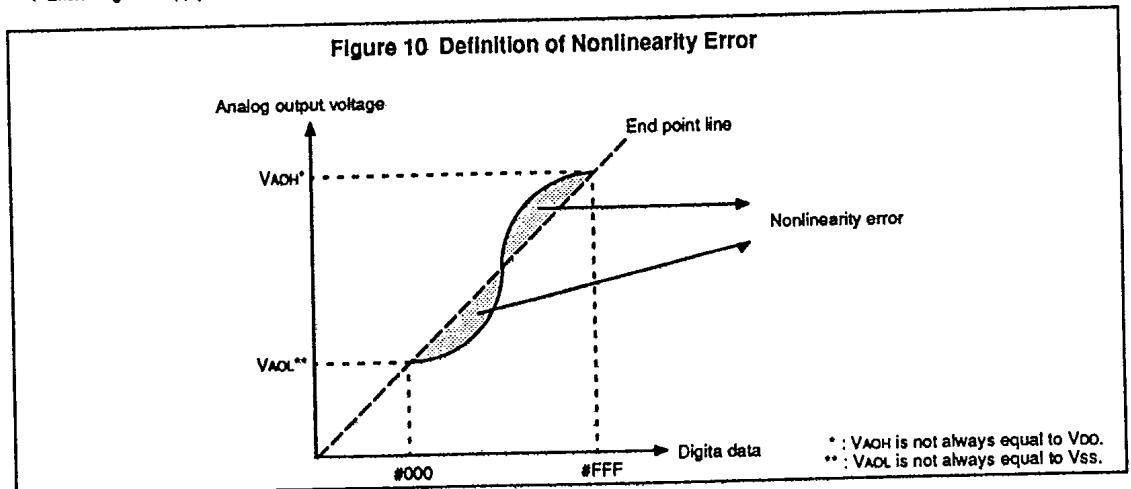

T-51-09-12

**MB88351**

**AC CHARACTERISTICS**

(Recommended operating conditions unless otherwise noted.)

Parameter	Symbol	Value		Unit	Condition
		Min	Max		
Clock Low Time	t <sub>CKL</sub>	200		ns	
Clock High Time	t <sub>CKH</sub>	200		ns	
Clock Rise Time	t <sub>Cr</sub>		200	ns	
Clock Fall Time	t <sub>Cf</sub>		200	ns	
Data Setup Time	t <sub>DCH</sub>	30		ns	
Data Hold Time	t <sub>CHD</sub>	60		ns	
Load Strobe High Time	t <sub>LDH</sub>	100		ns	
Load Strobe Setup Time	t <sub>CHL</sub>	200		ns	
Load Strobe Hold Time	t <sub>LDC</sub>	100		ns	
DAC Output Settling Time	t <sub>DD</sub>		30	μs	*R <sub>AL</sub> = 10 kΩ, C <sub>AL</sub> = 50 pF
Data Output Delay Time	t <sub>DO</sub>	70	350	ns	**C <sub>L</sub> = 20 pF (Min.), 100 pF (Max.)

**Figure 11 AC Test Conditions**

• DAC Output Settling Time

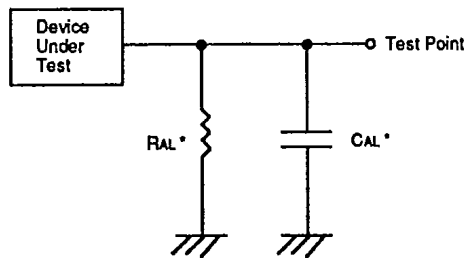

• Data Output Delay Time

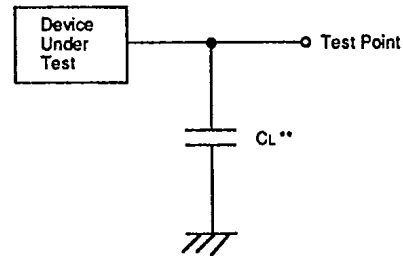

T-51-09-12

MB88351

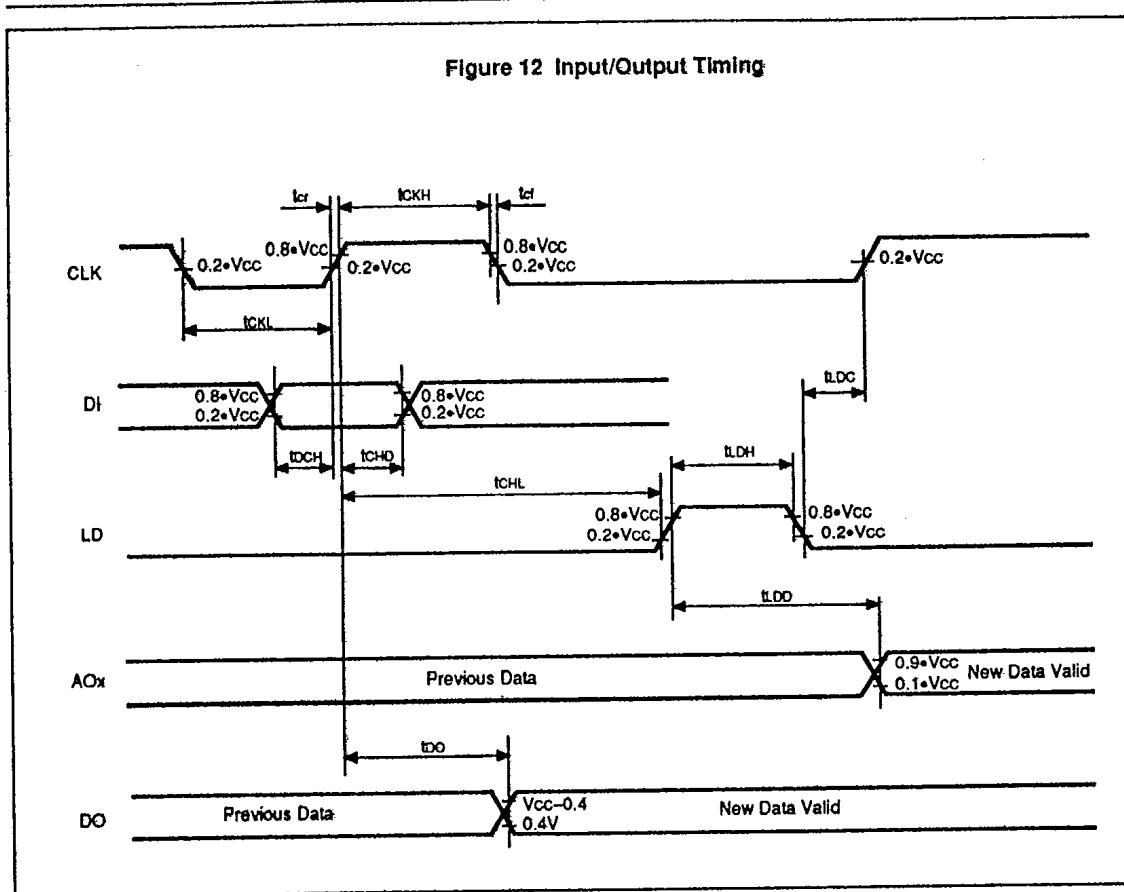

T-51-09-12

MB88351

Figure 13 Analog Output Voltage Range

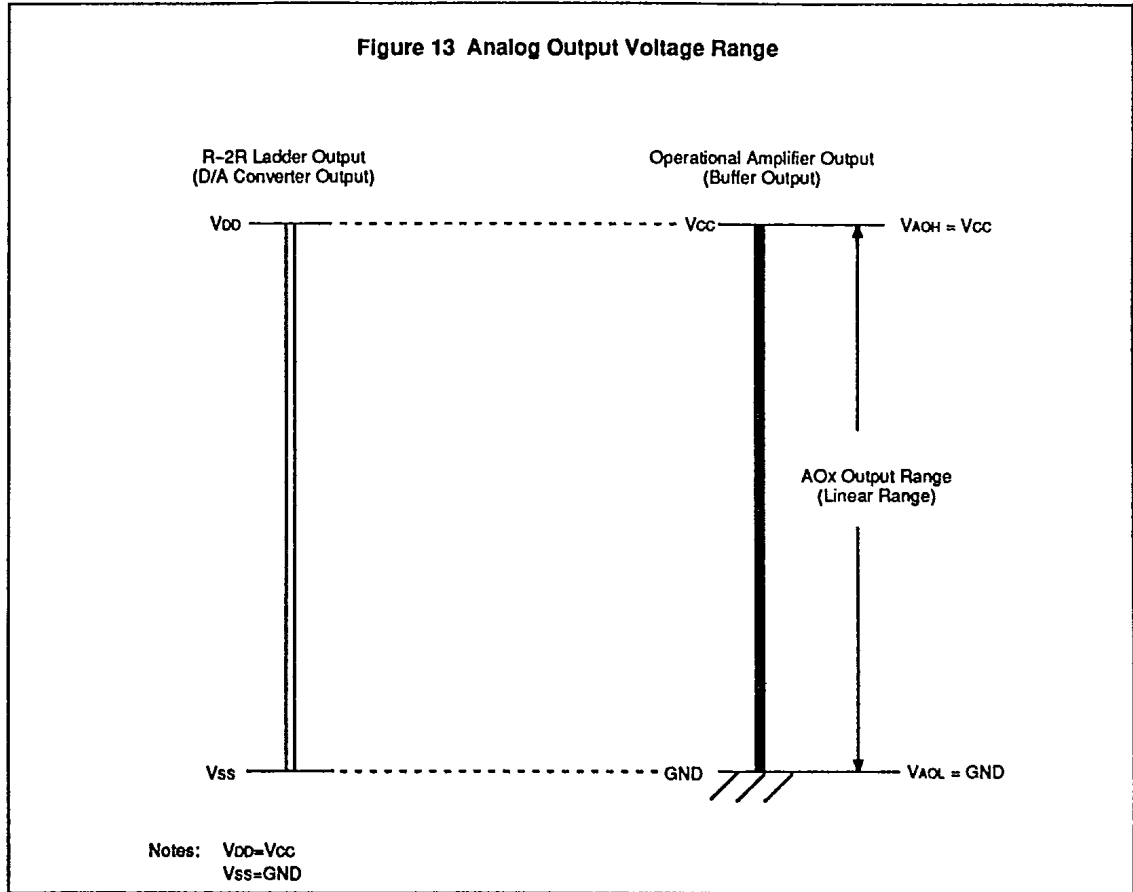



T-51-09-12

MB88351

### CHARACTERISTICS CURVE (Example)

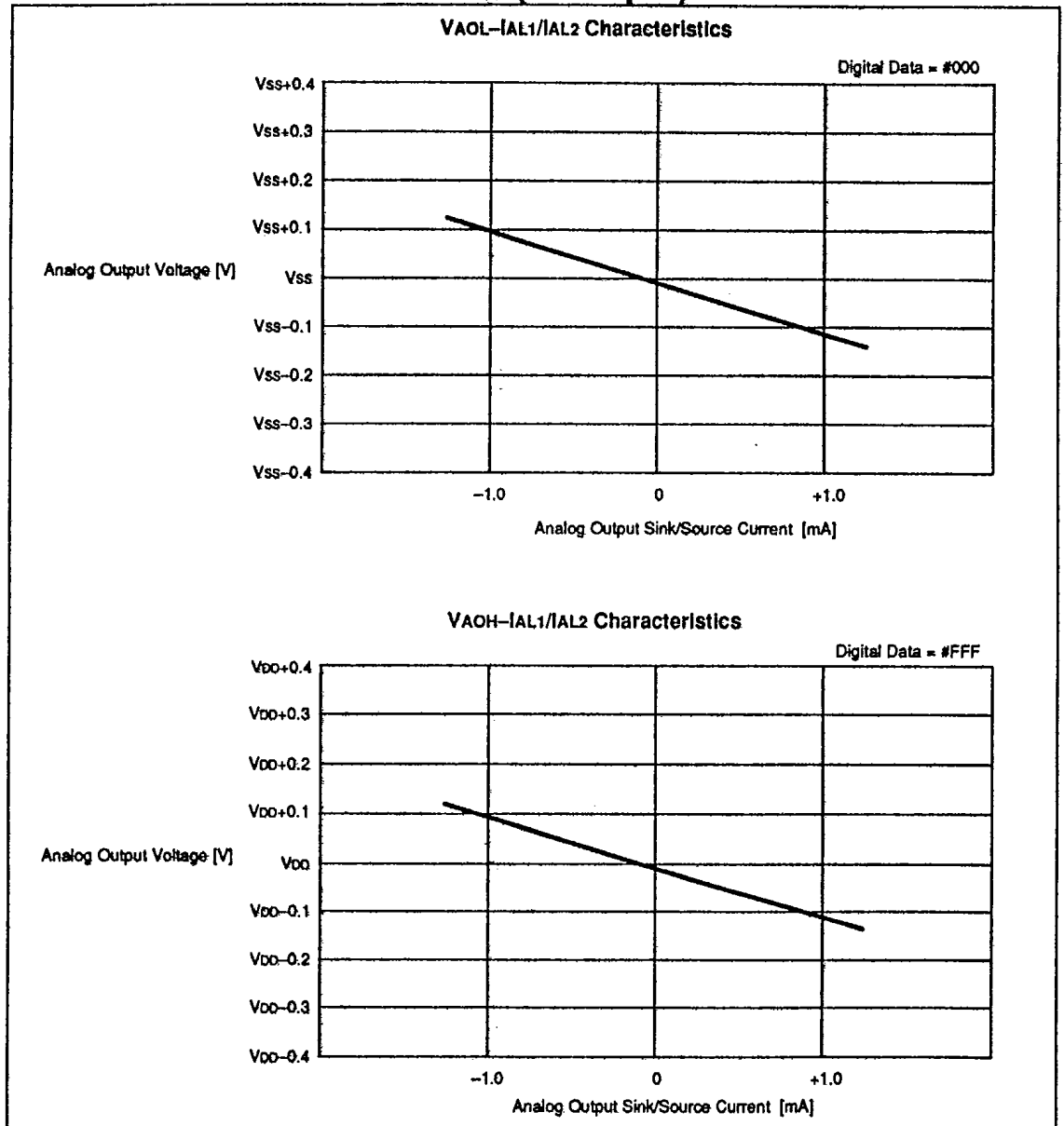

T-51-09-12

MB88351

PACKAGE DIMENSIONS

MB88351-P

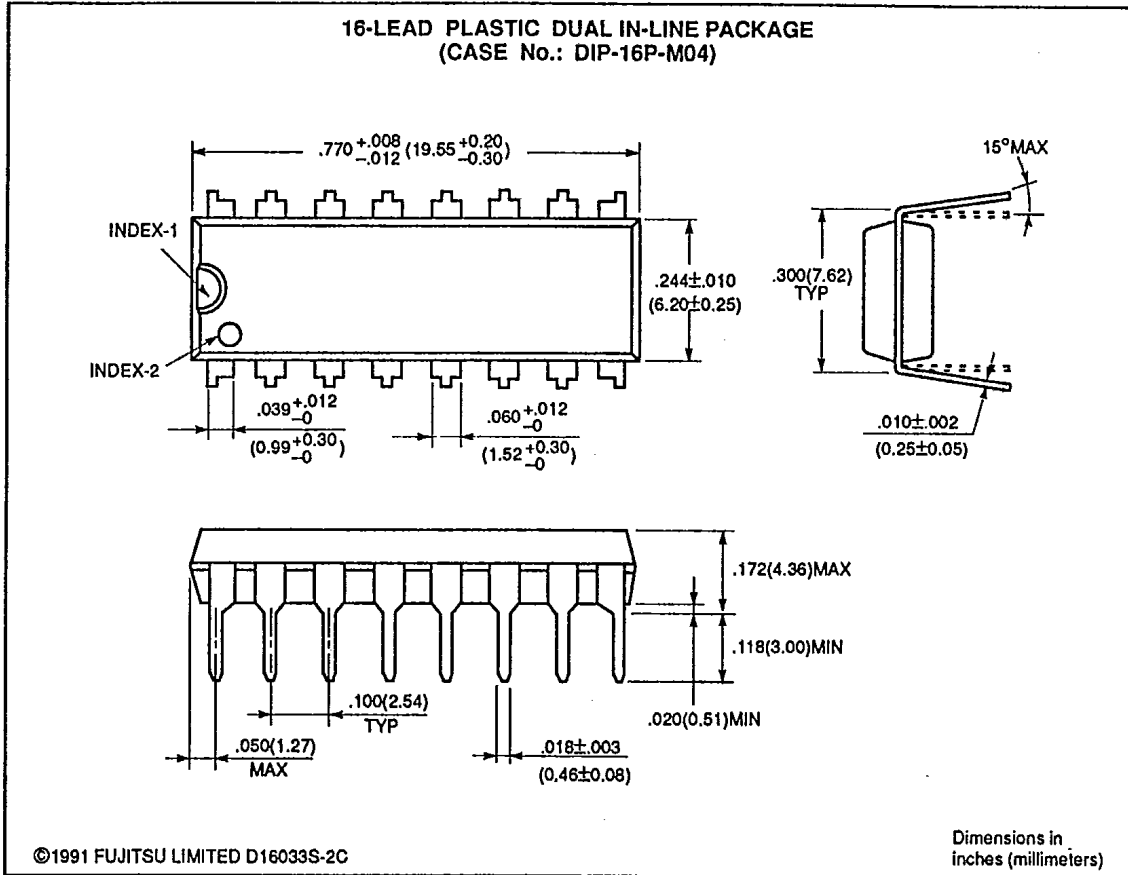

T-51-09-12

MB88351

MB88351-PF

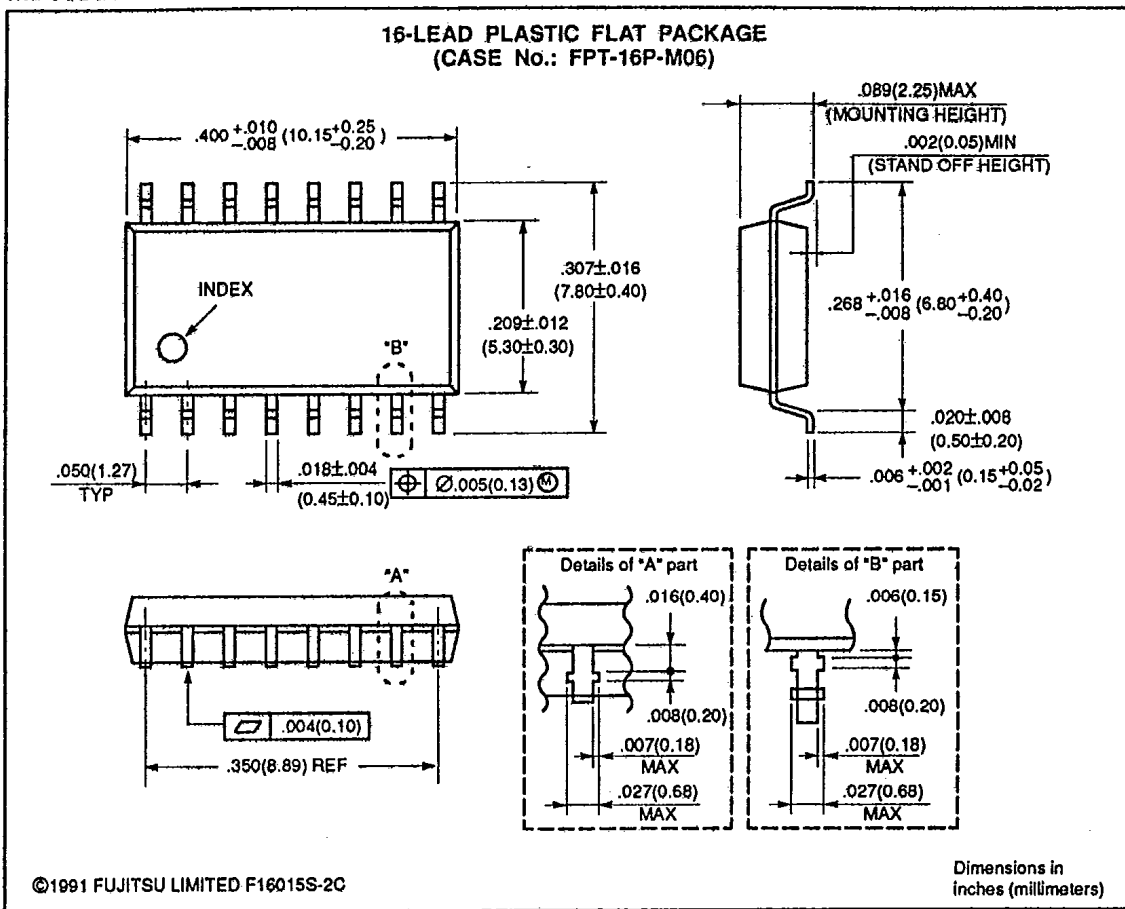

T-51-09-12

MB88351

MB88351-PFV

20-LEAD PLASTIC FLAT PACKAGE  
(CASE No.: FPT-20P-M03)

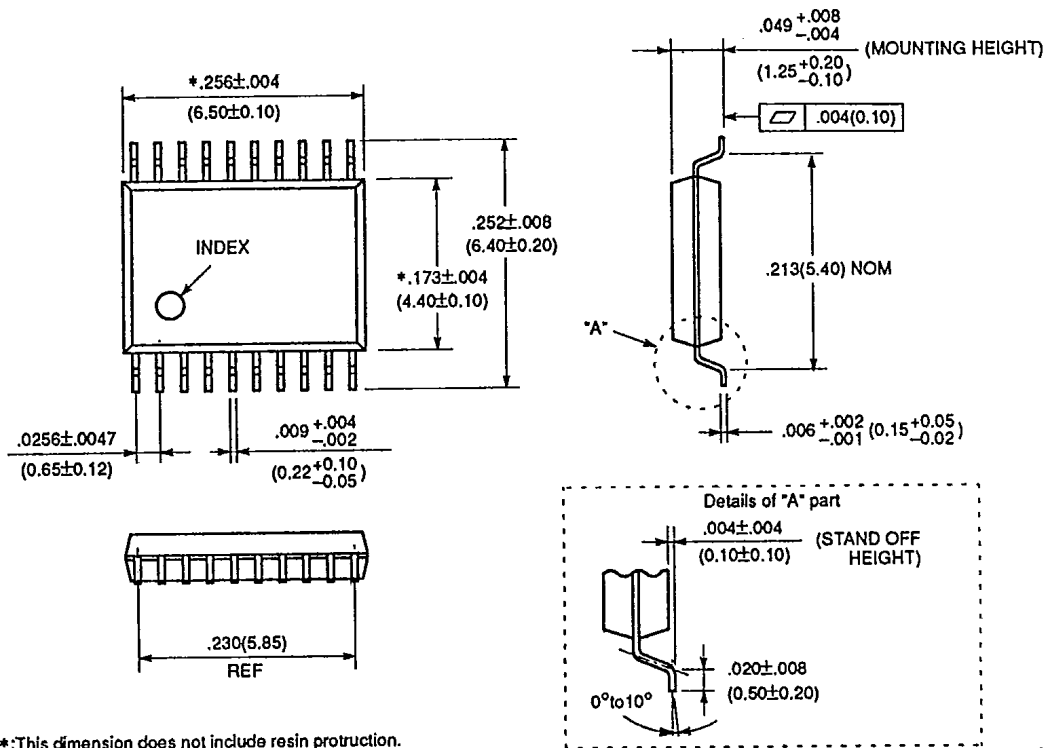

\*This dimension does not include resin protrusion.

©1991 FUJITSU LIMITED F20012S-2C

Dimensions in inches (millimeters)