

Axial Filament Halogen Lamp

DESCRIPTION AND FEATURES

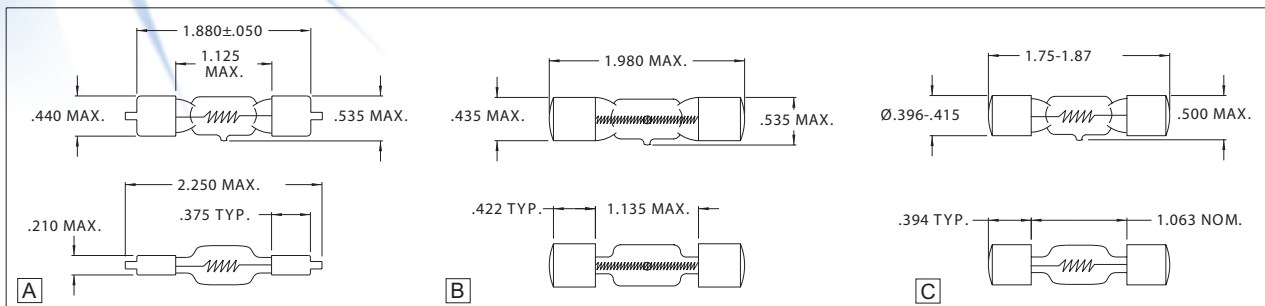

All dimensions in inches.

Description:

These Axial Filament Halogen Lamps were primarily designed for aircraft navigation lights although their unique configurations, rugged construction and exceptionally high light output make them the ideal light source for many applications.

Part No.	Volts	Watts	Filament Shape	Nominal MSCP	Laboratory Life Hours	Configuration
CM1964	28.0	150	30° Spot	230	1000	A
CM1967	28.0	150	12° N Spot	210	1000	A
CM1970*	28.0	100	38° Flood	150	1000	A
CM1970X	28.0	100	12° N Spot	140	1000	A
CM1978X*	10.0	100	38° Flood	130	2000	B
CM8-A103	28.0	50	12° N Spot	60	1000	C

* Lamp has a supported filament.

Materials:

- Globe: Quartz Glass
- Base: Nickel Plated Brass
- Atmosphere: Halogen Gas

Caution:

These halogen cycle lamps may shatter if scratched or damaged. Use these lamps in fixtures designed for their high operating temperature. Always turn power off when changing these lamps. For satisfactory performance limit the seal and wire lead temperature to 350°C to avoid deterioration. Maintain a minimum lamp wall temperature of 250°C to assure the halogen cycle occurs. Remove all grease and fingerprints from these lamps before operation. Never exceed the design voltage of these lamps.