

**INTRODUCTION**

The S1T8513A is designed for FM IF Detection on the pager set. It includes a voltage regulator, low battery detection circuit, Mixer, Oscillator, FSK comparator and limiting IF Amplifier.

**FEATURES**

- Operating voltage range: 1.0 ~ 4.0V
- Typical supply current: 1.1mA at 1.4V
- Low battery detection circuit (alarm function): 1.05V
- Voltage regulator :  $V_{reg} = 1.0V$  (Typ.)
- Mixer operating frequency: 10 ~ 50MHz
- High transmitting rate: 1200 / 2400bps
- FSK Data reception
- Package type: 20-SSOP (0.65mm)

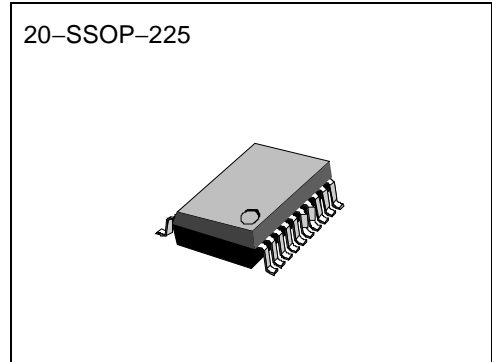

**ORDERING INFORMATION**

Device	Package	Operating Temperature
S1T8513A02-V0B0	20-SSOP-225	-20°C to +70°C

**BLOCK DIAGRAM**

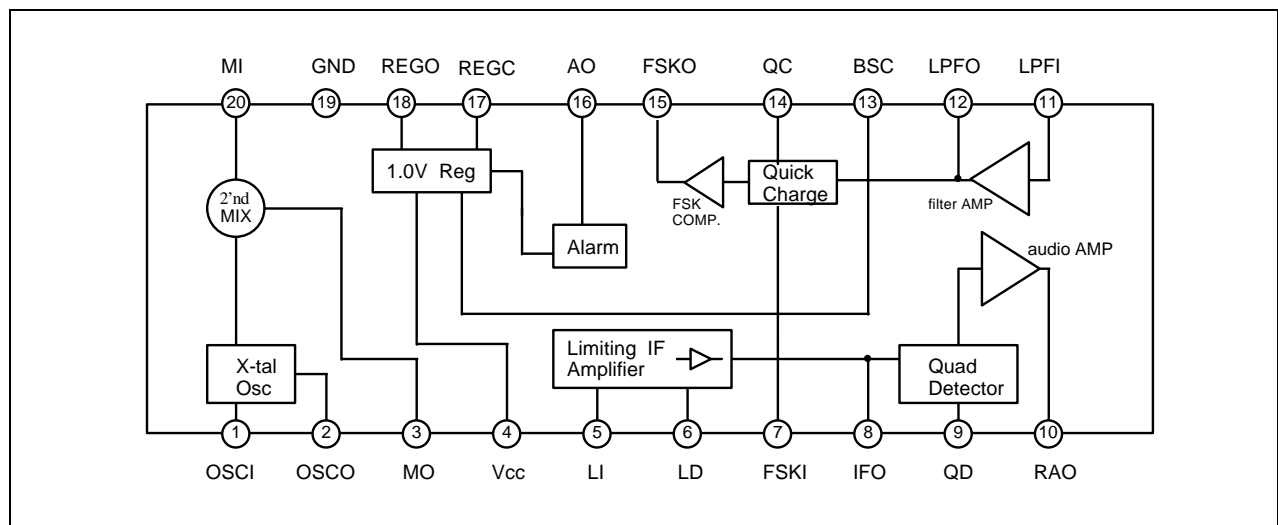

## PIN CONFIGURATION

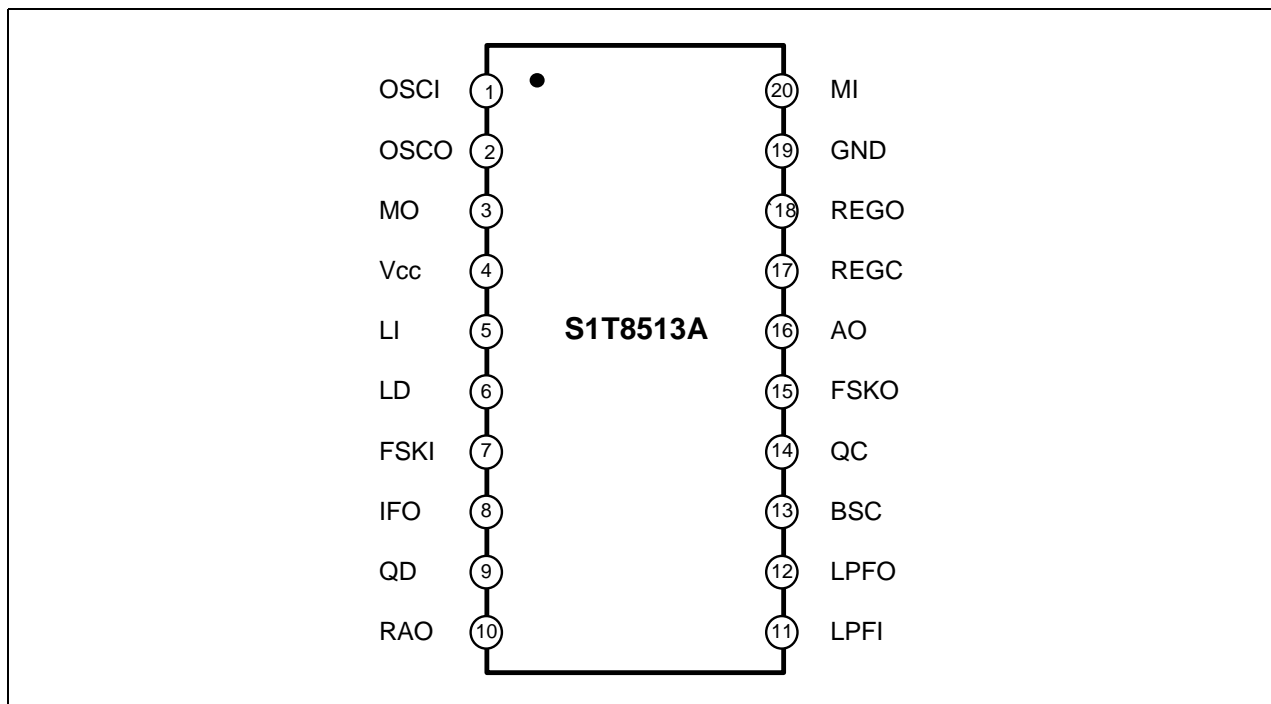

## PIN DESCRIPTION

Pin No	Symbol	Description
1	OSCI	Oscillator input. The oscillator is an internally-biased colpitts type.
2	OSCO	Oscillator output.
3	MO	Mixer output pin. Output impedance $\approx 2k\Omega$ . Connect a 455kHz filter between this pin and the LI.
4	V <sub>CC</sub>	V <sub>CC</sub> pin.
5	LI	IF limiter amplifier input. Input impedance $2k\Omega$ .
6	LD	Bypass capacitor connect pin for the IF limiter amplifier.
7	FSK1	Differential Amp. reference input on the FSK comparator.
8	IFO	IF Amp output.
9	QD	Quadrature detection, phase shifter pin.
10	RAO	Recovered audio signal output.
11	LPFI	Low pass filter amplifier input. Bias is supplied from pin 10.
12	LPFO	Low pass filter amplifier output.
13	BSC	Battery saving control pin. High: Battery saving off. Low: Battery saving on
14	QC	Quick charge control pin. High: Quick charge-discharge on. Low: Quick charge-discharge off.
15	FSKO	FSK signal output pin.
16	AO	Alarm output. This pin becomes High when V <sub>CC</sub> drops below 1.05V.
17	REGC	S1T8513A has an internal PNP transistor. But, it also can support an external PNP transistor to control the power.
18	REGO	Regulated voltage output.
19	GND	Ground.
20	MI	Mixer input impedance $\approx 5k\Omega$ .

## ABSOLUTE MAXIMUM RATINGS

Characteristic	Symbol	Value	Unit
Max. Supply Voltage	V <sub>CC (MAX)</sub>	4	V
Power Dissipation	P <sub>D</sub>	800	mW
Operating Temperature	T <sub>OPR</sub>	-20 — +70	°C
Storage Temperature	T <sub>STG</sub>	-55 — +125	°C

## ELECTRICAL CHARACTERISTICS

( $V_{CC} = 1.4V \pm 5\%$ ,  $f_{IN(2MIX)} = 21.4MHz$ ,  $f_{DEV} = \pm 4.8kHz$ ,  $f_{MOD} = 600Hz$ ,  $T_a = 25^\circ C$ , unless otherwise specified)

Characteristic	Symbol	Test Conditions	Min.	Typ.	Max.	Unit
Operating current	$I_{CCN}$	No Input Signal	–	1.1	1.6	mA
	$I_{CCS}$	Battery Saving	–	0	10	$\mu A$
Alarm Detection Voltage	$V_{AD}$	–	1.0	1.05	1.1	V
Alarm Low Level Output Voltage	$V_{O(AL)}$	$I = 100\mu A$	–	–	0.4	V
Alarm High Level Leakage Current	$I_{LKG(AL)}$	–	–	–	2	$\mu A$
FSK Low Level Output Voltage	$V_L(FSK)$	$I = 100\mu A$	–	–	0.4	V
FSK High Level Leakage Current	$I_{LKG(FSK)}$	–	–	–	2	$\mu A$
Regulator Output Voltage	$V_{O(REG)}$	–	0.95	1.0	1.05	V
Quick Charge Current	$I_C$	–	50	70	–	$\mu A$
Input for –3dB Sensitivity	$V_{LIM}$	Mixer Input	–	2.5	7.5	$\mu V_{rms}$
Input for –12dB SINAD Sensitivity	$V_{I(SEN)}$	IF Input	–	6.0	18.0	$\mu V_{rms}$
Recovered Audio Output Voltage	$V_{O(RAO)}$	$V_{IN(2MIX)} = 500\mu V_{rms}$	37	55	73	mVrms
Mixer Conversion Voltage Gain	$\Delta G_V(M)$	Ceramic Filter loss = –1dB	8	12	16	dB
Signal to Noise Ratio	S/N	$V_{IN(2MIX)} = 500\mu V_{rms}$	38	55	–	dB
Total Harmonic Distortion	THD	$V_{IN(2MIX)} = 500\mu V_{rms}$	–	2.0	3.5	%
Mixer 3rd Order Intercept Point	3RD	–	–	–10	–	dBm
Mixer Input Resistance	$R_I(MIX)$	–	3.5	5	6.5	k $\Omega$
Limiting Amplifier Input Resistance	$R_I(LA)$	–	1.4	2	2.6	k $\Omega$
AM Rejection Ratio	AMR	$V_{IN(2MIX)} = 5\mu V_{rms}$ (AM = 300%)	25	40	–	dB
Data Shaping Output Duty Ratio	DR	$V_{IN(2MIX)} = 500\mu V_{rms}$	40	50	60	%

APPLICATION CIRCUIT

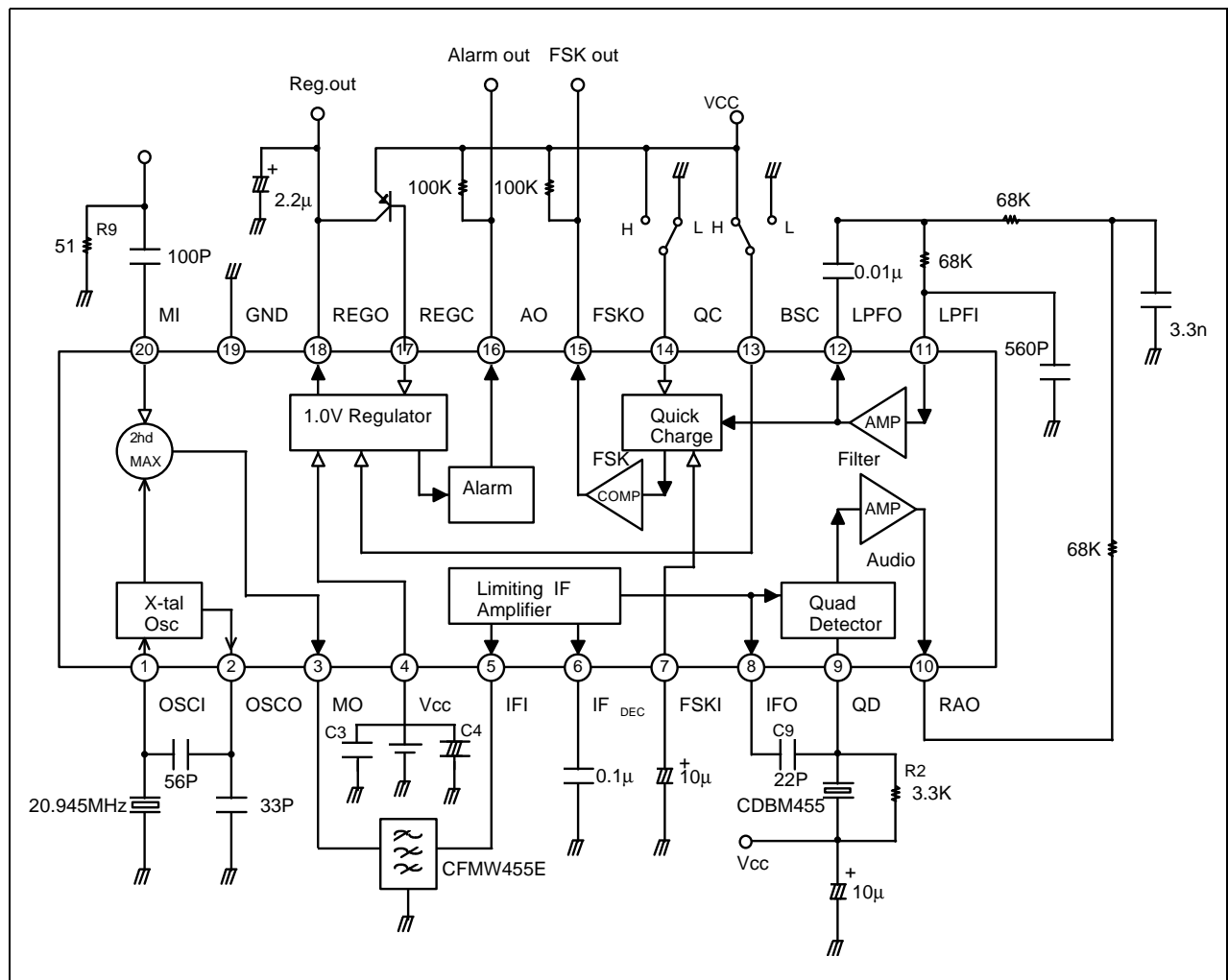

NOTES