

INTRODUCTION

The S1T3361D is designed for use in FM dual conversion communication. It contains a complete narrow band FM demodulation system operable to less than 2.5V supply voltage. This low-power narrow-band FM IF system provides the second converter, second IF, demodulator. Filter Amp and squelch circuitry for communications and scanning receivers.

FEATURES

- Low power consumption (4.0mA typ. at $V_{CC} = 4.0V$)
- Excellent input sensitivity (-3dB limiting, $2.0\mu V_{rms}$ typ.)
- Minimum number of external components required.
- Operating Voltage: 2.5 to 7.0V

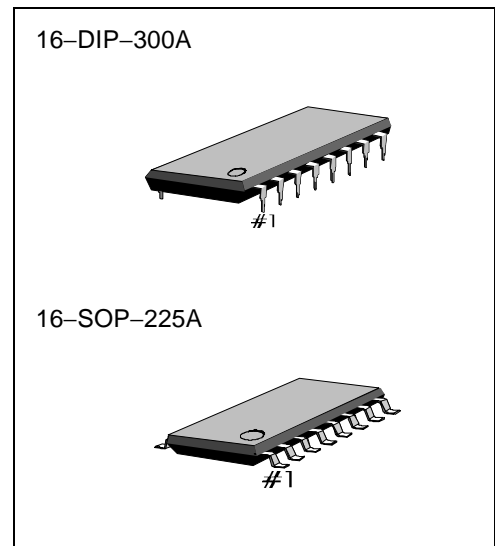

APPLICATIONS

- Cordless phone (for home usage)
- FM dual conversion communications equipment

ORDERING INFORMATION

Device	Package	Operating Temperature
S1T3361D01-D0B0	16-DIP-300A	- 20°C to +70°C
S1T3361D01-S0B0	16-SOP-225A	

PIN CONFIGURATION

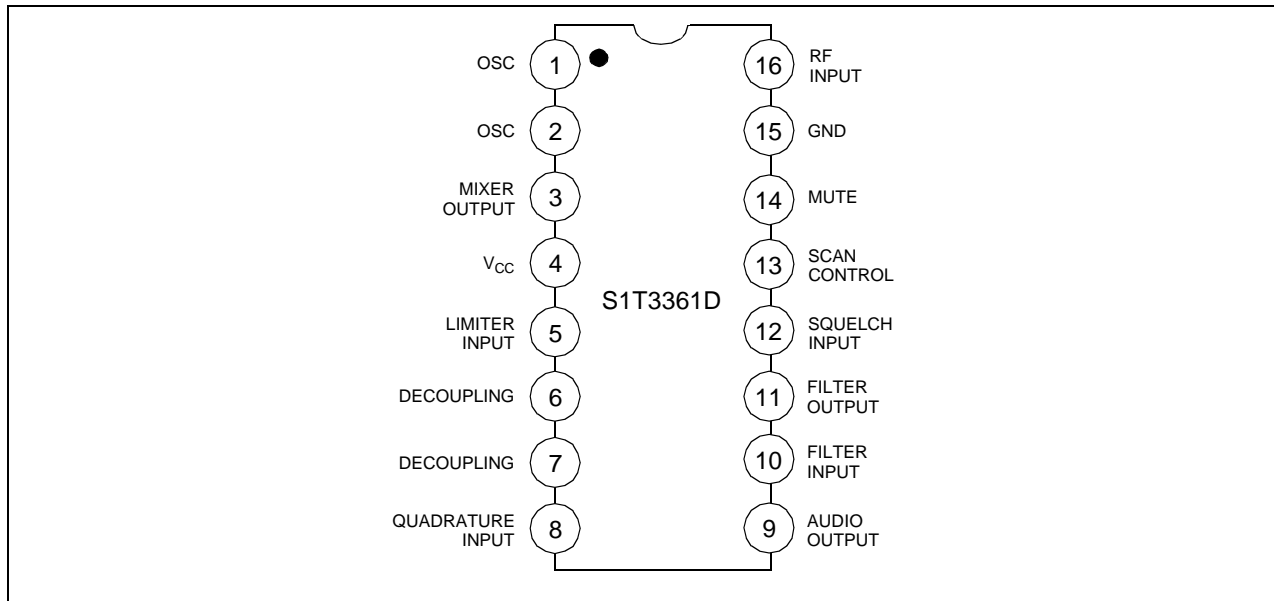

ABSOLUTE MAXIMUM RATINGS

Characteristic	Symbol	Value	Unit
Max. Supply Voltage	$V_{CC (MAX)}$	10	V
Supply Voltage Range	V_{CC}	2.5 to 7.0	V
Detector Input Voltage	$V_{I (DET)}$	1.0	V_{P-P}
RF Input Voltage ($V_{CC} \geq 4.0V$)	$V_{I (RF)}$	1.0	V_{rms}
Mute Function	V_{MUTE}	- 0.5 to + 0.5	V_{peak}
Operating Temperature	T_{OPR}	- 20 to + 70	$^{\circ}C$
Storage Temperature	T_{STG}	- 65 to + 150	$^{\circ}C$

NOTE:

Absolute maximum ratings are those values beyond which permanent damage to the device may occur. These are stress ratings only and functional operation of the device at or beyond them is not implied. Long exposure to these conditions may affect device reliability.

ELECTRICAL CHARACTERISTICS

($V_{CC} = 4.0V$, $f_o = 10.7MHz$, $\Delta f = \pm 3kHz$, $f_{MOD} = 1kHz$, $T_a = 25^\circ C$, unless otherwise specified)

Characteristic	Symbol	Test Conditions	Min.	Typ.	Max.	Unit
Operating Current	I_{CC}	Squelch off ($V_{12} = 2V$)	2.0	4.0	8.0	mA
		Squelch on ($V_{12} = GND$)	3.0	6.0	10	mA
Input Limiting Voltage	$V_{I(LIM)}$	-3.0dB limiting	–	2.0	6.0	μV
Detector Output Voltage	$V_{O(DET)}$	–	–	2.0	–	V_{dc}
Detector Output Impedance	$Z_{O(DET)}$	–	–	400	–	W
Recoverd audio output voltage	V_O	$V_{in} = 10mV$	134	150	168	mV_{rms}
Filter Gain	G_V	$f = 10kHz$, $V_{in} = 5mV$	40	48	52	dB
Filter Output DC Voltage	$V_{O(DC)}$	–	1.0	1.5	2.0	V_{dc}
Trigger Hysteresis of Filter	V_{TH}	–	–	50	–	mV
Mute Switch-on Resistance	$R_{ON(MUTE)}$	Mute Low	–	10	40	Ω
Mute Switch-off Resistance	$R_{OFF(MUTE)}$	Mute High	1	–	10	$M\Omega$
Scan Control Low Output	$V_{L(SCAN)}$	Mute off ($V_{12} = 2V$)	–	–	0.5	V_{dc}
Scan Control High Output	$V_{H(SCAN)}$	Mute on ($V_{12} = GND$)	3.0	–	–	V_{dc}
Mixer Conversion Gain	$G_V(MIXER)$	–	30	36	–	dB
Mixer Input Resistance	$R_I(MIXER)$	–	–	3.3	–	$k\Omega$
Mixer Input Capacitance	$C_I(MIXER)$	–	–	2.2	–	pF

CHARACTERISTIC GRAPH

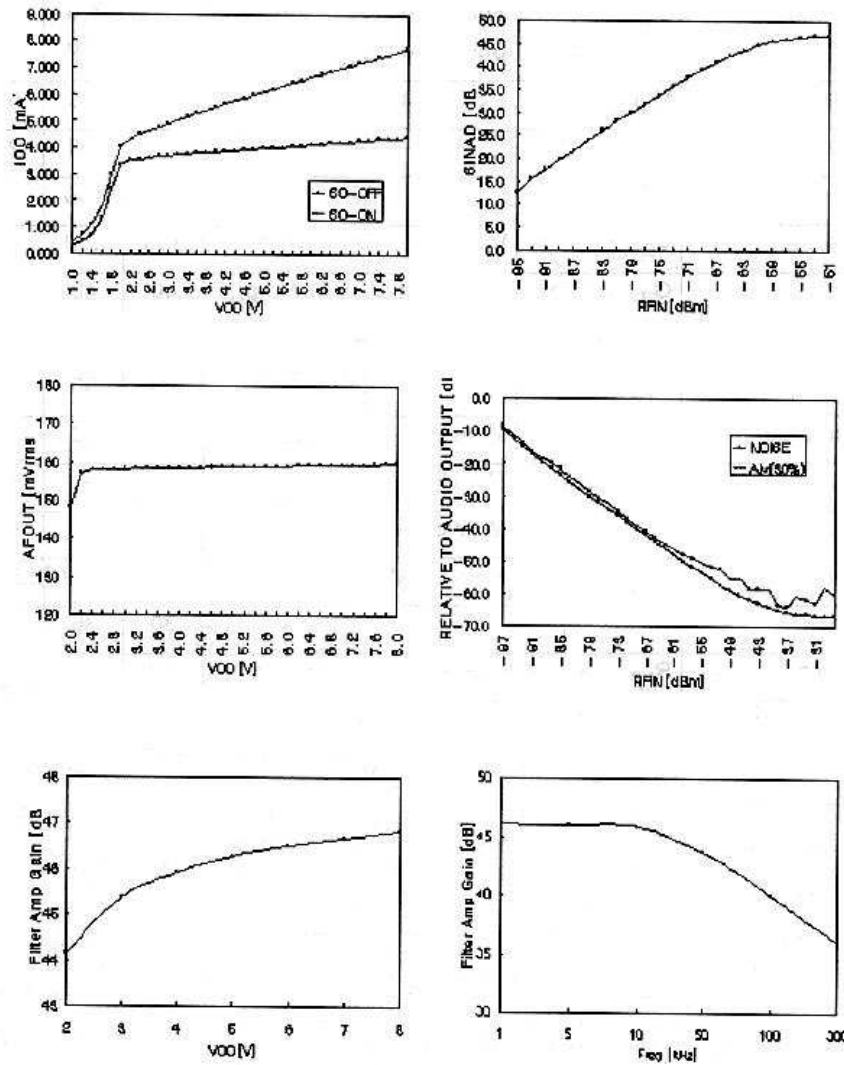

APPLICATION CIRCUIT

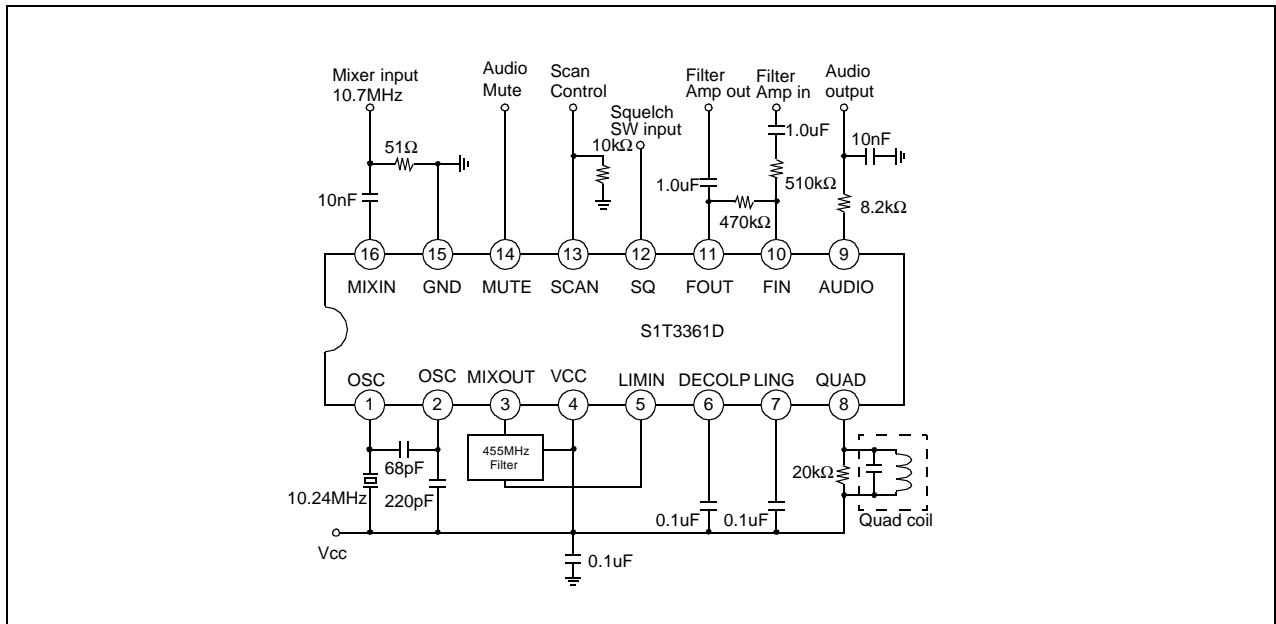

In the above application circuit, the audio signal is recovered using a conventional quadrature FM detector. The absence of an input signal is indicated by the presence of noise above the desired audio frequencies. This “noise band” is monitored by an active filter and a detector. A squelch trigger circuit indicates the presence of noise (or a tone) by an output which can be used to control scanning. At the same time, an internal switch is operated which can be used to mute the audio.

NOTES