

CT2520-23 Series

LOW POWER +5 VOLTS ONLY TRANSCEIVER FOR MIL-STD-1553B

GENERAL DESCRIPTION

The CT2520 + 5V only transceiver is a third generation hybrid device utilizing custom monolithic drivers and receivers. This allows the device to be operated from a single + 5V supply. This design results in lower power and 100% duty cycle is permissible at 125°C case temperature. Each driver dissipates less than 1.0 watt at 25% duty cycle.

FEATURES

- Monolithic +5V only drivers
- AC interstage coupling prevents static burnout
- Receiver filtered to improve S/N ratio of system
- 20mV typical output offset
- TTL compatible
- Available to Standard Military Drawings, please consult your nearest Customer Service Centre

TRANSCEIVER	TYPE	PACKAGE	NOTES
CT2520	DUAL	36PIN DIL OR FP	
CT2521	DUAL	36PIN DIL OR FP	1
CT2522	SINGLE	24PIN DIL OR FP	1
CT2523	SINGLE	44PIN LCC	

Note 1: PLUG IN PIN FOR PIN COMPATIBLE with Industry Standard Transceivers

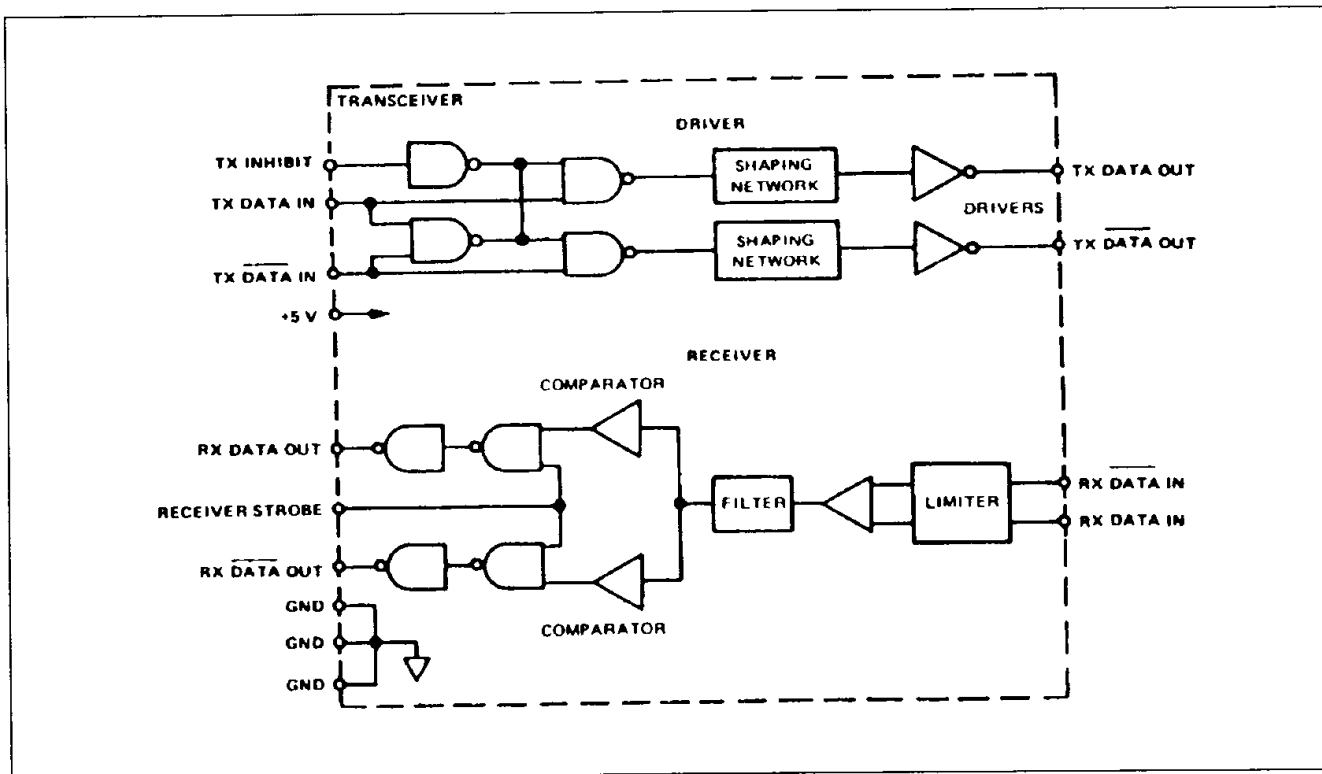

Figure 1: Functional Diagram

CT2520-23 Series

ELECTRICAL CHARACTERISTICS, RECEIVER SECTION

PARAMETER / CONDITION	SYMBOL	MIN	TYP	MAX	UNIT
INPUT CHARACTERISTICS					
Differential Input/Output (Inherited) Impedance DC to 1MHz, Total Hybrid	Z_{in}	3.5K			ohms
Differential voltage range	V_{idr}	$\pm 20V$			V_{peak}
Input common mode voltage range	V_{icr}	$\pm 10V$			V_{peak}
Common mode rejection ratio (from point A)	CMRR	40			dB
STROBE characteristics					
(Logic "0" inhibits output)					
"0" input current ($V_S = 0.4V$)	I_{il}			-1	mA
"1" input current ($V_S = 2.7V$)	I_{ih}			40	μA
"0" input voltage	V_{il}			0.7	V
"1" input voltage	V_{ih}	2			V
Threshold characteristics (sine wave at 1 MHz)	V_{th1}	0.6		1.2	Vp-p
NOTE: Threshold voltages refer to point A.					
Filter characteristics				8	Vp-p
(sine wave input)	V_{th2}	1.5			Vp-p
	V_{th3}	5			Vp-p
OUTPUT CHARACTERISTICS					
"1" state ($I_{source} = 400\mu A$)	V_{oh}	2.4	3.4		
"0" state ($I_{sink} = 4mA$)	V_{oh}			0.5	
NOTE: With receiver input below threshold both RX DATA OUT and RX DATA OUT remain in "0" state.					
Delay (average) from differential input zero crossings to RX DATA OUT and RX DATA OUT output 50% points	t_{DRX}		300	450	ns

ELECTRICAL CHARACTERISTICS, DRIVER SECTION

PARAMETER / CONDITION	SYMBOL	MIN	TYP	MAX	UNIT
INPUT CHARACTERISTICS					
"0" input current ($V_{in} = 0.4V$)	I_{il}			-1	mA
"1" input current ($V_{in} = 2.7V$)	I_{ih}			40	μA
"0" input voltage	V_{il}			0.7	V
"1" input voltage	V_{ih}	2			V
Delay from TX INHIBIT (0 → 1) to inhibited output impedance	t_{DXOFF}		150	225	ns
Delay from TX INHIBIT (1 → 0) to active output impedance	t_{DXON}		100	150	ns
Differential output noise	V_{noi}			10	mVp-p
OUTPUT CHARACTERISTICS					
Differential output level at point 8, (145-ohm load)	V_O	25	27	35	Vp-p
Rise and fall times (10% - 90% of p-p output)	t_r	100	160	300	ns
Output offset at point A (35-ohm load) 2.5 μs after mid-bit crossing of parity bit of last word of a 660 μs message	V_{OS}		± 20	± 75	mV peak
Delay from 50% point of TX DATA IN or TX DATA IN to zero crossing of differential output	t_{DTX}		100	200	ns

POWER AND THERMAL DATA, TOTAL HYBRID (DRIVER AND RECEIVER)

PARAMETER / CONDITION	SYMBOL	MIN	TYP	MAX	UNIT
Power supply voltages	V_{cc}	4.5	5.0	5.5	V
Power dissipation of most critical (hottest) device in hybrid during continuous transmission (100% duty cycle)	CT2520 P_c CT2521/2/3	Note 1		1500 250	mW mW
Thermal resistance, most critical device	CT2520 θ_{jc} CT2521/2/3			10 60	°C/W °C/W
Junction to case temperature rise of most critical device at 100% duty cycle transmission	CT2520/1/2/3 T_{jc}			15	°C
Total supply current "standby" mode, or transmitting at less than 1% duty cycle (e.g. 20µs of transmission every 2ms or longer interval)	I_{cc}		55	70	mA
Total supply current transmitting at 1MHz into a 35-ohm load at point A	*DUTY CYCLE				
	25% 100%	I_{cc25} I_{cc100}	Note 2 Note 2	150 430	180 550

*One Channel Only

Note 1: Decreases linearly to zero at zero duty cycle.

Note 2: Decreases linearly to applicable "stand by" value at zero duty cycle.

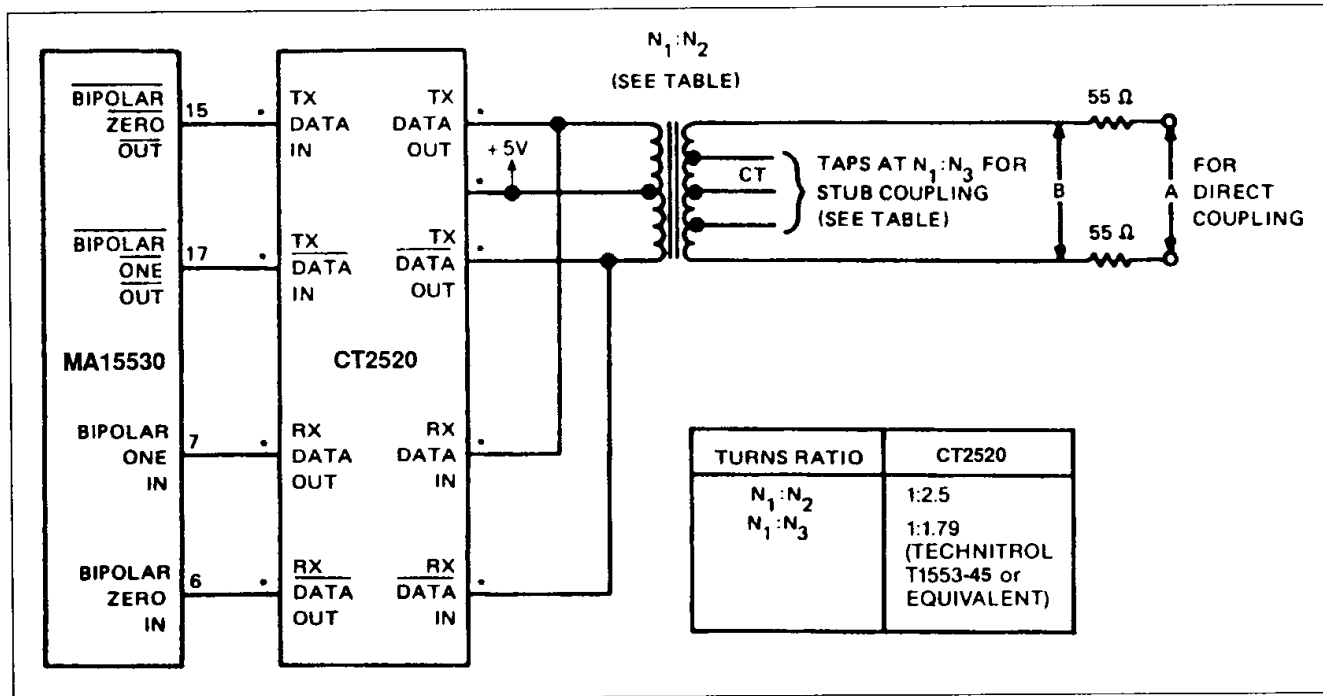

Figure 2: Typical Input/Output Connections - CT2520

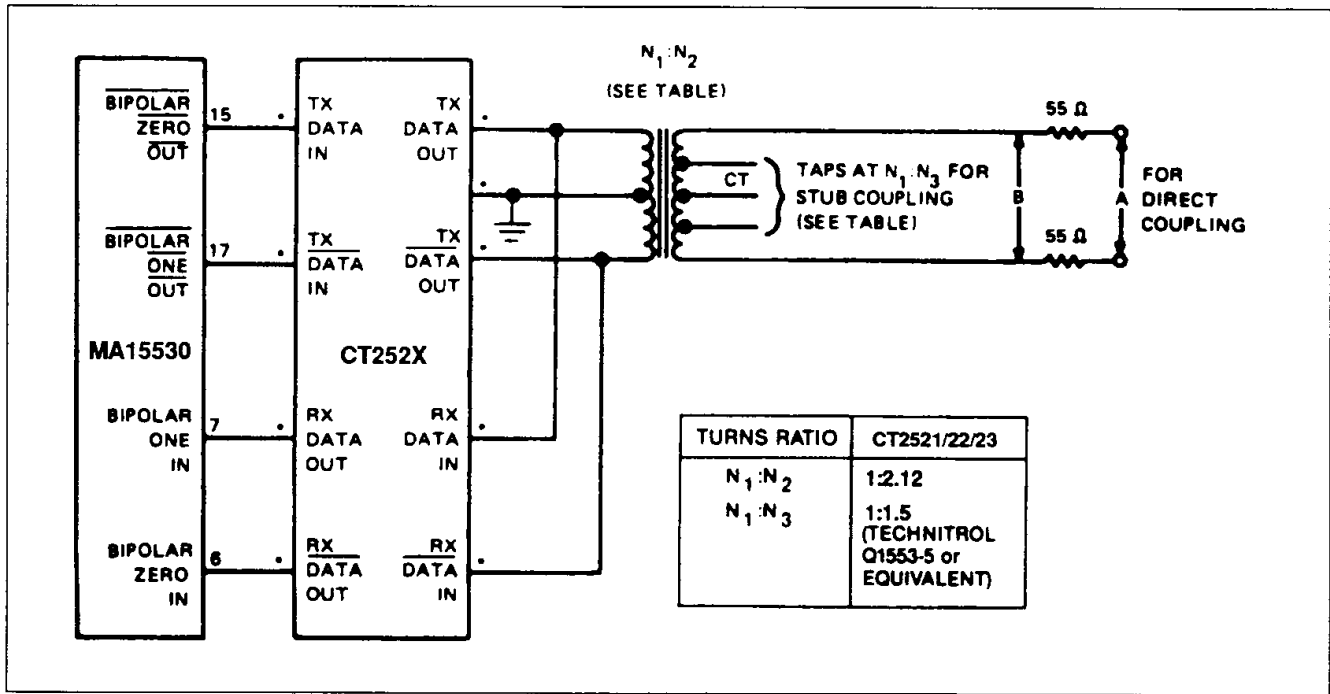

Figure 3: Typical Input/Output Connections - CT2521/22/23

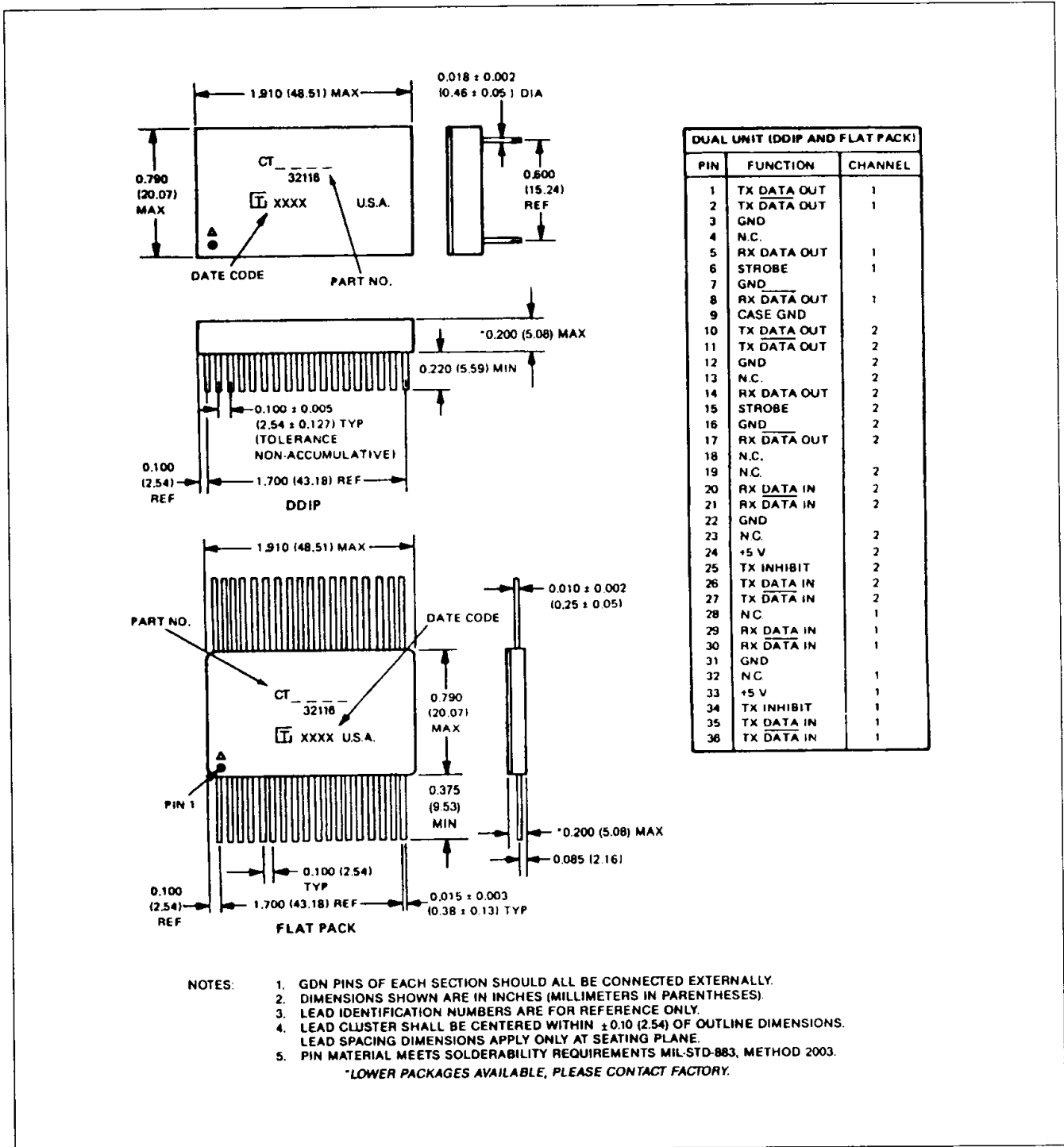
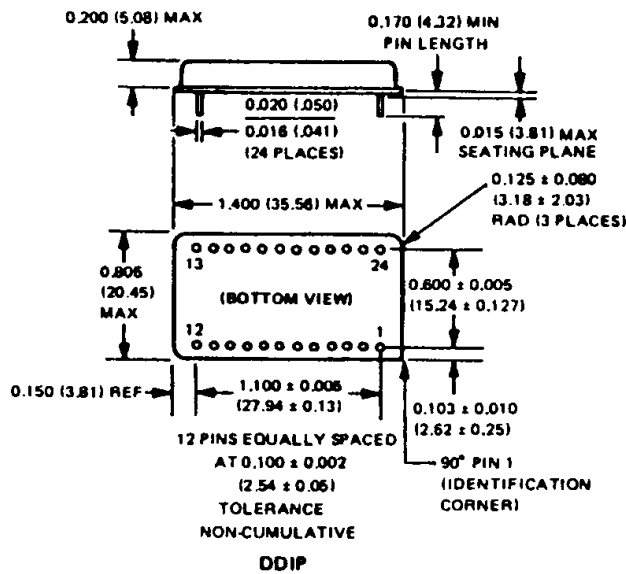
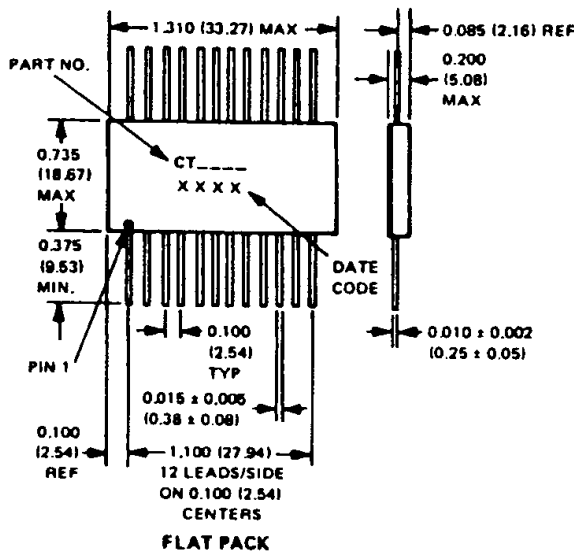

Figure 4: Mechanical Outline and Pinouts (Dual Unit) CT2520/21



SINGLE UNIT (DDIP AND FLAT PACK)			
PIN	FUNCTION	PIN	FUNCTION
1	TX DATA OUT	13	N.C.
2	TX DATA OUT	14	N.C.
3	GND	15	RX DATA IN
4	N.C.	16	RX DATA IN
5	N.C.	17	N.C.
6	N.C.	18	GND
7	RX DATA OUT	19	N.C.
8	STROBE	20	+5 V
9	GND	21	TX INHIBIT
10	RX DATA OUT	22	TX DATA IN
11	N.C.	23	TX DATA IN
12	N.C.	24	N.C.



NOTES:

1. DIMENSIONS SHOWN ARE IN INCHES (MILLIMETERS IN PARENTHESES).
2. LEAD IDENTIFICATION NUMBERS ARE FOR REFERENCE ONLY.
3. LEAD CLUSTER SHALL BE CENTERED WITHIN ± 0.10 (2.54) OF OUTLINE DIMENSIONS. LEAD SPACING DIMENSIONS APPLY ONLY AT SEATING PLANE.
4. PIN MATERIAL MEETS SOLDERABILITY REQUIREMENTS OF MIL-STD-202E, METHOD 208C.

NOTES:

1. GDN PINS OF EACH SECTION SHOULD ALL BE CONNECTED EXTERNALLY.
2. DIMENSIONS SHOWN ARE IN INCHES (MILLIMETERS IN PARENTHESES).
3. LEAD IDENTIFICATION NUMBERS ARE FOR REFERENCE ONLY.
4. LEAD CLUSTER SHALL BE CENTERED WITHIN ± 0.10 (2.54) OF OUTLINE DIMENSIONS. LEAD SPACING DIMENSIONS APPLY ONLY AT SEATING PLANE.
5. PIN MATERIAL MEETS SOLDERABILITY REQUIREMENTS MIL-STD-883, METHOD 2003.

*LOWER PROFILE PACKAGES AVAILABLE, PLEASE CONTACT FACTORY.

Figure 5: Mechanical Outline and Pinouts - CT2522

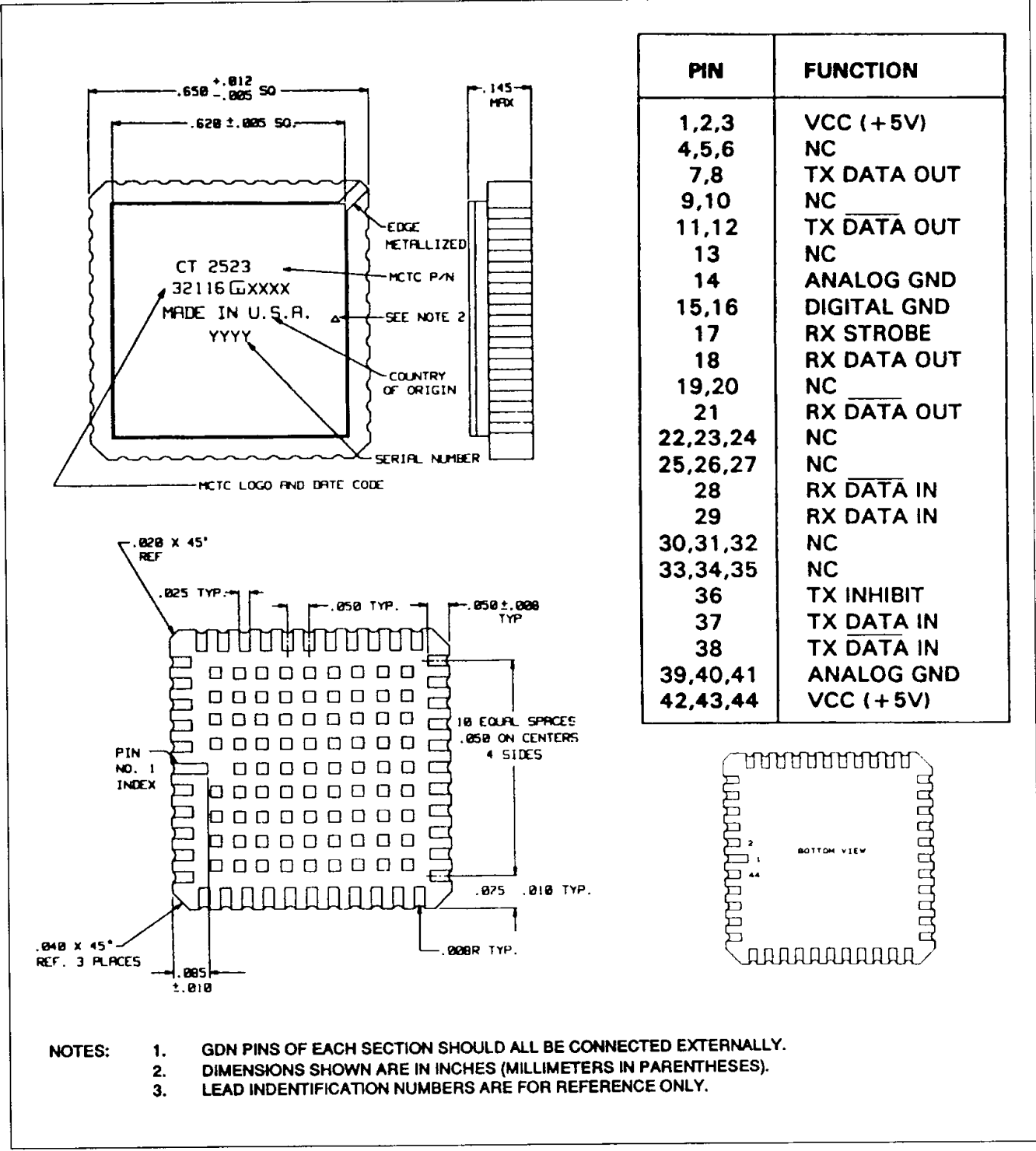

Figure 6: Mechanical Outline and Pinouts - CT2523

CT2520-23 Series

RECOMMENDED DESIGN PRACTICES

(a) DECOUPLING

Decouple V_{cc} to ground, close to the hybrid with a $>10\mu\text{F}$ tantalum capacitor in parallel with a 100nF ceramic bypass capacitor.

Note: Peak transmission current drawn from V_{cc} is 650mA.

(b) PCB LAYOUT

- Full PCB ground - planning is recommended.
- It is good practice to ensure connections from encoder/decoder to 'TXLOGICIN', 'TXLOGICIN' and 'TXINHIBIT' are as short as possible and of balanced length, shape and area. Optimum results are obtained when these signals have minimum rise/fall times and minimum differential delays.
- Connections between 'TXDATAOUT' and the center tapped transformer should be designed to:
 - (i) Withstand peak transmission currents at required operating duty cycles
 - (ii) Minimise added series inductance
 - (iii) Ensure system capacitance in conjunction with transceiver and transformer impedances does not reduce overall input impedance below the value stated in MIL-STD-1553B.

These connections should also be balanced in terms of length, shape and area.