

Description:

The CT222ADM is an isolated dual photovoltaic MOSFET driver used when a high degree of electrical isolation is required.

The driver can isolate the MOSFET from more sensitive control circuitry and enable the source and drain connections to reach any potential within the range of the isolation voltage. High photo efficiency produces fast turn on. A low off state impedance insures fast turn off and immunity from dv/dt when the MOSFET is in the off state.

The CT222ADM is packaged in an 8 pin hermetically sealed ceramic dip and is designed for high reliability applications.

Dual MOSFET Driver Active Discharge

Pin Connections

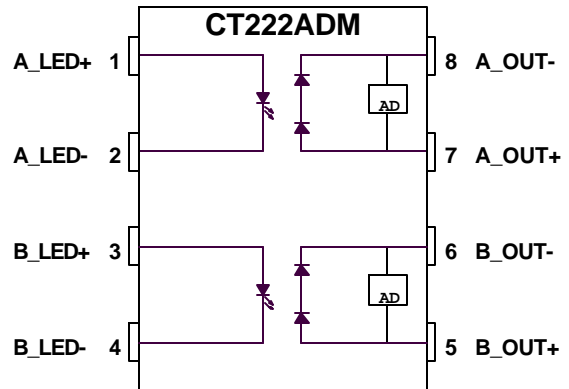

Features

- Active Gate Discharge Circuitry
- Optical Isolation
- High Isolation Voltage
- Dual Independent Channels
- Wide Operating Temperature Range

Applications

- Gate Drive Power MOSFETS
- Solid State Relays
- Process Controls
- Switching Power Supplies
- DC Motor Control

Mechanical Dimensions

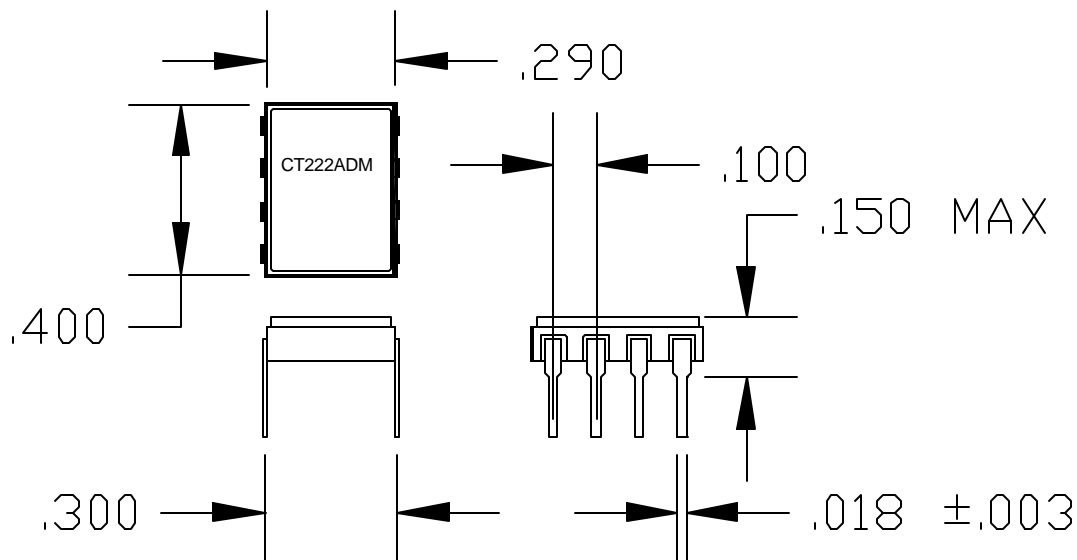

Absolute Maximum Ratings (Per Channel, Tc= -55°C to +125°C unless otherwise specified)

Parameter	Condition	Rating	Units
Led Forward Current	Steady State	50	mA
Led Forward Current	Peak, 10% Duty Cycle	75	mA
Led Reverse Voltage	Reverse Current = -10 mA	5	V
Output Voltage	Open Circuit	18	V
Output Current	Led Current = 50 mA	75	mA
Operating Temperature		-55 to 125	°C
Storage Temperature		-55 to 150	°C
Isolation Voltage		1000	V

Electrical Characteristics (Per Channel)

Parameter	Symbol	Test Conditions	Min	Typ	Max	Units
Short Circuit Current	I _{SC}	LED Current = 10 mA, V _o = 0 V	10	15		µA
		LED Current = 20 mA, V _o = 0 V	20	25		
		LED Current = 30 mA, V _o = 0 V	30	40		
Open Circuit Voltage	V _{OC}	LED Current = 10 mA	13.0	14.0		V
		LED Current = 20 mA	13.5	14.5		
		LED Current = 30 mA	14.0	15.0		
LED Forward Voltage	V _{F(LED)}	LED Current = 20 mA		1.3	1.5	V
LED Reverse Current	I _{R(LED)}	V _R = -5.0 V	-5.0	-0.1		µA
Off State Voltage	V _(OFF)	LED Current = 0.0 mA, I _o = -10 µA		0.65	0.85	V
Isolation Voltage	V _(ISO)		2500			V _{DC}
Isolation Voltage	R _(ISO)	V _{IN} to V _{OUT} = 100V	100k			MΩ

