



- Cadmium - free contacts
- Miniature size
- Automotive applications
- High inrush current
- Dust cover available
- PCB mounting

Contacts

Contact number & arrangement	see Table 1		
Contact material	AgSnO ₂ ; AgSnO ₂ /Au 0,2 μm		
Voltage			
Max. switching voltage AC/DC	60 V / 60 V		
Min. switching voltage	1 V		
Current	1C/O	1NO	2NO
Min. switching current	10 mA	10 mA	10 mA
Max. inrush current	110 A / 50 A (1NO/1NC)	110 A	2 x 110 A
Rated current	20 A / 12 A (1NO/1NC)	20 A	2 x 12,5 A
Max. breaking capacity	270 W / 162 W (1NO/1NC)	270 W	2 x 168 W
Min. breaking capacity	1 W	1 W	1 W
Resistance	≤ 3 mΩ		
Max. operating frequency			
• at rated load	900 cycles/hour (2 s ON/ 2 s OFF)		
• at motor load	450 cycles/hour (2 s ON/ 6 s OFF)		
• at lamp load	120 cycles/hour (2 s ON/ 30 s OFF)		
• no load	36 000 cycles/hour		

Coil

Voltage	
Rated voltage	5...48 V DC
Must operate voltage (20°C)	≤ 0,6 U _n
Must release voltage	≥ 0,15 U _n
Operating range of supply voltage	see Table 1
Rated power consumption	1,44 W

Insulation

Voltage	
Insulation rated voltage	60 V AC
Dielectric strength:	
• coil-contact	500 V AC
• contact-contact	500 V AC
Contact-coil distance	
• clearance	≥ 1 mm
• creepage	≥ 1 mm

General data

Operating time (typical value)	10 ms
Release time (typical value)	3 ms
Electrical life	
• for 1C/O version	> 10 ⁵ at 20/12 A (1NO/1NC); 13,5 V DC
• for 1N/O version	> 10 ⁵ at 20 A; 13,5 V DC
• for 2N/O version	> 10 ⁵ at 2 x 12,5 A; 13,5 V DC
Mechanical life (cycles)	> 10 ⁷
Dimensions (L x W x H)	18,6 x 13 x 18,5 mm (IP 00 - without cover) 15,3 x 20,5 x 19,7 mm (IP 40 - with cover)
Weight	12 g
Ambient temperature	
• storing	-40...+100 °C
• operating	-40...+85 °C
Cover protection category	IP 00 or IP 40
Solder bath temperature	max. 270 °C
Soldering time	max. 5 s
Approvals	GOST

Coil data

Table 1

Coil code	Rated voltage V DC	Coil resistance (±10%) at 20 °C	Coil operating range at 85 °C V DC	
			min.	max.
1005	5	18	4,0	6,6
1006	6	24	4,8	8,0
1009	9	55	7,2	12,0
1012	12	100	9,6	16,0
1015	15	152	12,0	20,0
1018	18	230	14,4	23,9
1024	24	390	19,2	31,9
1048	48	1 590	38,4	63,8

Connections diagram (pin side view)

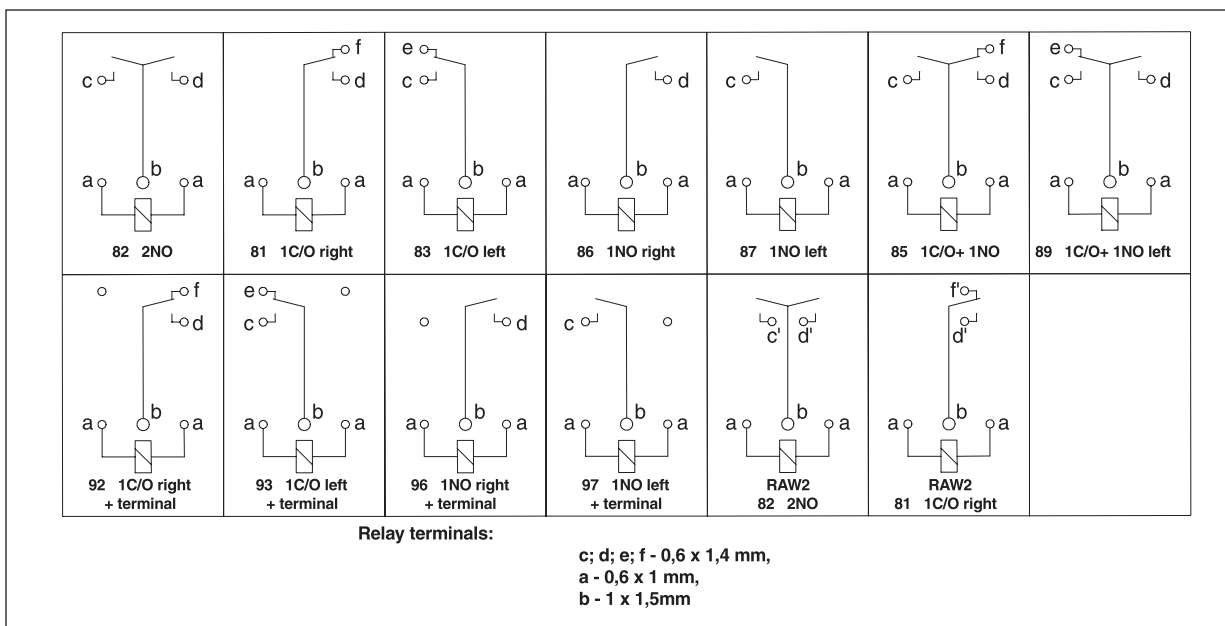

Dimensions

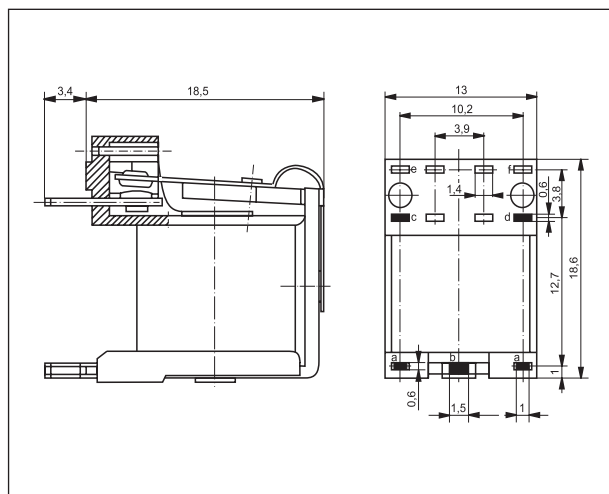

Max. DC resistive load breaking capacity

Fig. 1

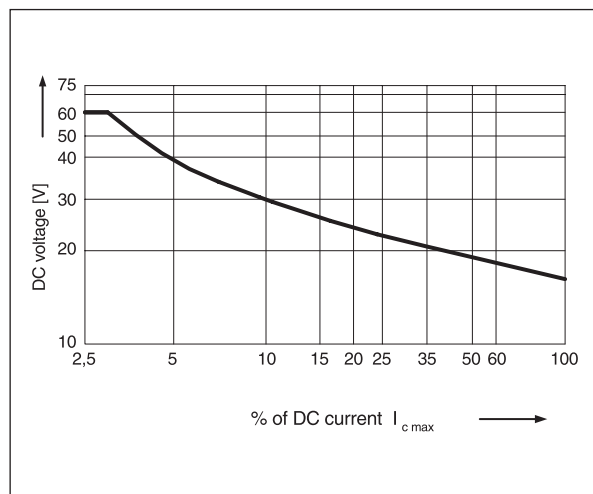

Mounting

Relays **RA2** are designed for direct PCB mounting.

Ordering codes

