



DC COMPONENTS CO., LTD.  
DISCRETE SEMICONDUCTORS

MID112

TECHNICAL SPECIFICATIONS OF NPN DARLINGTON TRANSISTOR

Description

Designed for general purpose power and switching such as output or driver stages in applications such as switching regulators, converters, and amplifiers.

Pinning

- 1 = Base
- 2 = Collector
- 3 = Emitter

Absolute Maximum Ratings (TA=25°C)

Characteristic	Symbol	Rating	Unit
Collector-Base Voltage	V <sub>CB0</sub>	100	V
Collector-Emitter Voltage	V <sub>CEO</sub>	100	V
Emitter-Base Voltage	V <sub>EBO</sub>	5	V
Collector Current	I <sub>C</sub>	2	A
Total Power Dissipation (T <sub>C</sub> =25°C)	P <sub>D</sub>	20	W
Junction Temperature	T <sub>J</sub>	+150	°C
Storage Temperature	T <sub>STG</sub>	-55 to +150	°C

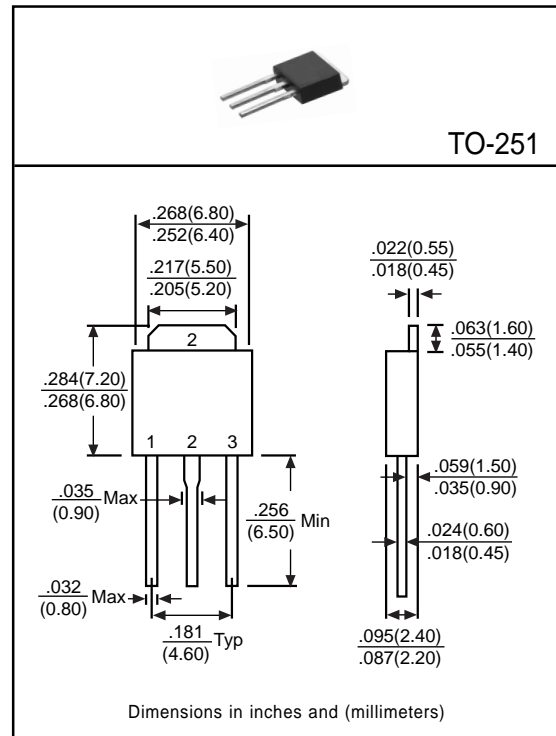

Electrical Characteristics

(Ratings at 25°C ambient temperature unless otherwise specified)

Characteristic	Symbol	Min	Typ	Max	Unit	Test Conditions
Collector-Base Breakdown Voltage	BV <sub>CB0</sub>	100	-	-	V	I <sub>C</sub> =1mA
Collector-Emitter Breakdown Voltage	BV <sub>CEO</sub>	100	-	-	V	I <sub>C</sub> =30mA
Collector Cutoff Current	I <sub>CB0</sub>	-	-	10	μA	V <sub>CB</sub> =80V
	I <sub>CEO</sub>	-	-	20	μA	V <sub>CE</sub> =50V
Emitter Cutoff Current	I <sub>EBO</sub>	-	-	2	mA	V <sub>BE</sub> =5V
Collector-Emitter Saturation Voltage <sup>(1)</sup>	V <sub>CE(sat)</sub>	-	-	2.5	V	I <sub>C</sub> =2A, I <sub>B</sub> =8mA
Base-Emitter On Voltage <sup>(1)</sup>	V <sub>BE(on)</sub>	-	-	2.8	V	I <sub>C</sub> =2A, V <sub>CE</sub> =3V
DC Current Gain <sup>(1)</sup>	h <sub>FE1</sub>	500	-	-	-	I <sub>C</sub> =0.5A, V <sub>CE</sub> =3V
	h <sub>FE2</sub>	1K	-	12K	-	I <sub>C</sub> =2A, V <sub>CE</sub> =3V
	h <sub>FE3</sub>	200	-	-	-	I <sub>C</sub> =4A, V <sub>CE</sub> =3V
Output Capacitance	C <sub>ob</sub>	-	-	100	pF	V <sub>CB</sub> =10V

(1)Pulse Test: Pulse Width ≤ 380μs, Duty Cycle ≤ 2%