



Micro Commercial Components
 21201 Itasca Street Chatsworth
 CA 91311
 Phone: (818) 701-4933
 Fax: (818) 701-4939

UFT10005 THRU UFT10060

Features

- Supre Fast switching for high efficiency
- High Surge Capability
- Low Leakage
- Low Forward Voltage Drop
- High Current Capability

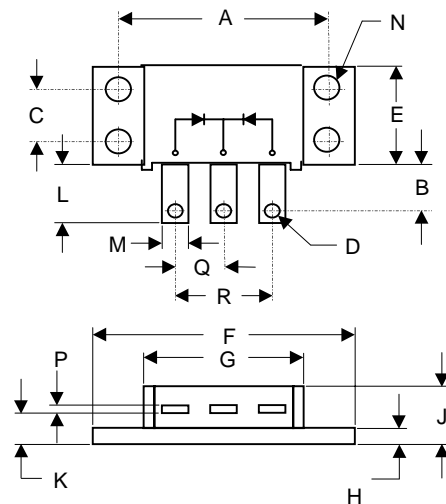
100 Amp Supre Fast Recovery Rectifier 50 to 600 Volts

Maximum Ratings

- Operating Temperature: -55°C to +175°C
- Storage Temperature: -55°C to +175°C

MCC Part Number	Maximum Recurrent Peak Reverse Voltage	Maximum RMS Voltage	Maximum DC Blocking Voltage
UFT10005	50V	35V	50V
UFT10010	100V	70V	100V
UFT10020	200V	40V	200V
UFT10040	400V	280V	400V
UFT10060	600V	420V	600V

POWERMOD



Electrical Characteristics @ 25°C Unless Otherwise Specified

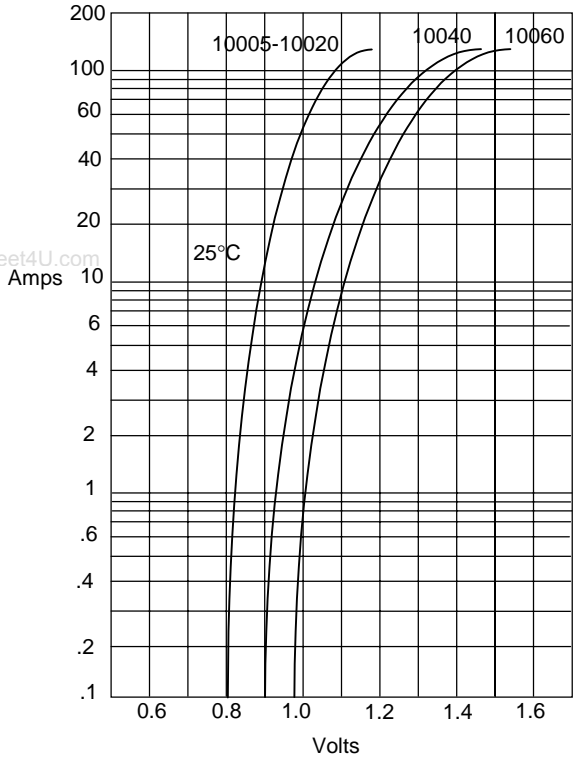
Average Forward Current	$I_{F(AV)}$	100 A	$T_C = 125^\circ\text{C}$
Peak Forward Surge Current 10005-10020 10040 10060	I_{FSM}	1000A 800 A 700 A	8.3ms, half sine
Maximum Instantaneous Forward Voltage 10005-10020 10040 10060	V_F	1.13V 1.25V 1.35V	$I_{FM} = 50.0\text{A};$ $T_J = 25^\circ\text{C}$
Maximum DC Reverse Current At Rated DC Blocking Voltage	I_R	50 μA 6mA	$T_J = 25^\circ\text{C}$ $T_J = 125^\circ\text{C}$
Maximum Reverse Recovery Time 10005-10020 10040 10060	T_{rr}	60ns 75ns 90ns	$I_F=0.5\text{A}, I_R=1.0\text{A},$ $I_{rr}=0.25\text{A}$
Typical Junction Capacitance 10005-10020 10040 10060	C_J	575pF 300pF 275pF	Measured at 1.0MHz, $V_R=10\text{V}$

DIM	DIMENSIONS				NOTE
	INCH ES		MM		
	MIN	MAX	MIN	MAX	
A	1.995	2.005	50.67	50.93	
B	.300	.325	7.62	8.26	
C	.495	.505	12.57	12.83	
D	.182	.192	4.62	4.88	
E	.990	1.010	25.15	25.65	
F	2.390	2.410	60.71	61.21	
G	1.490	1.510	37.85	38.35	
H	.120	.130	3.05	3.30	
J	-----	.400	-----	10.16	
K	.240	.260	6.10	6.60	
L	.490	.510	12.45	12.95	
M	.330	.350	8.38	8.90	
N	.175	.195	4.45	4.95	∅
P	.035	.045	0.89	1.14	
Q	.445	.455	11.30	11.56	
R	.890	.910	22.61	23.11	

*Pulse Test: Pulse Width 300 μsec , Duty Cycle 2%

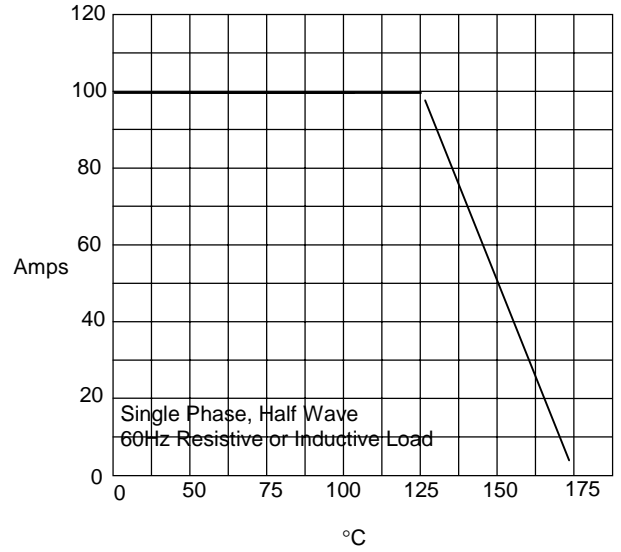


Figure 1
Typical Forward Characteristics



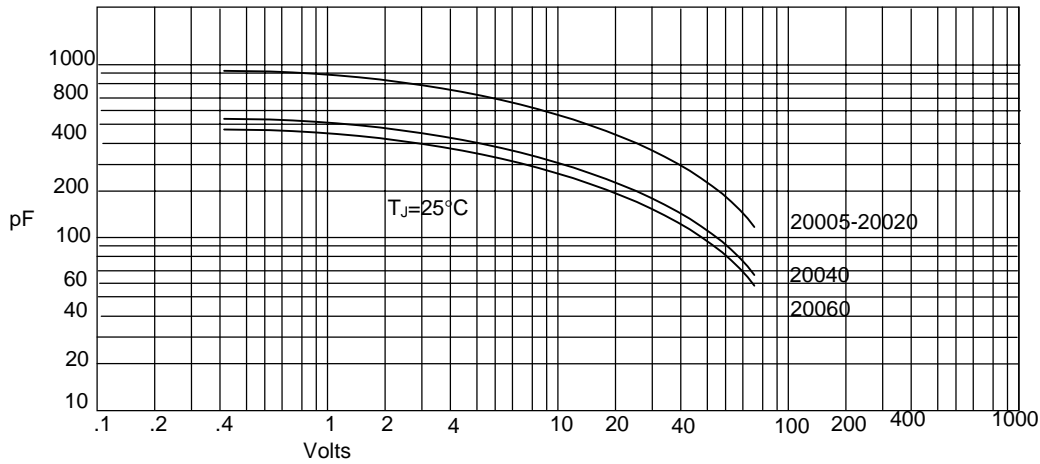
Instantaneous Forward Current - Amperes versus
Instantaneous Forward Voltage - Volts

Figure 2
Forward Derating Curve



Average Forward Rectified Current - Amperes versus
Case Temperature - °C

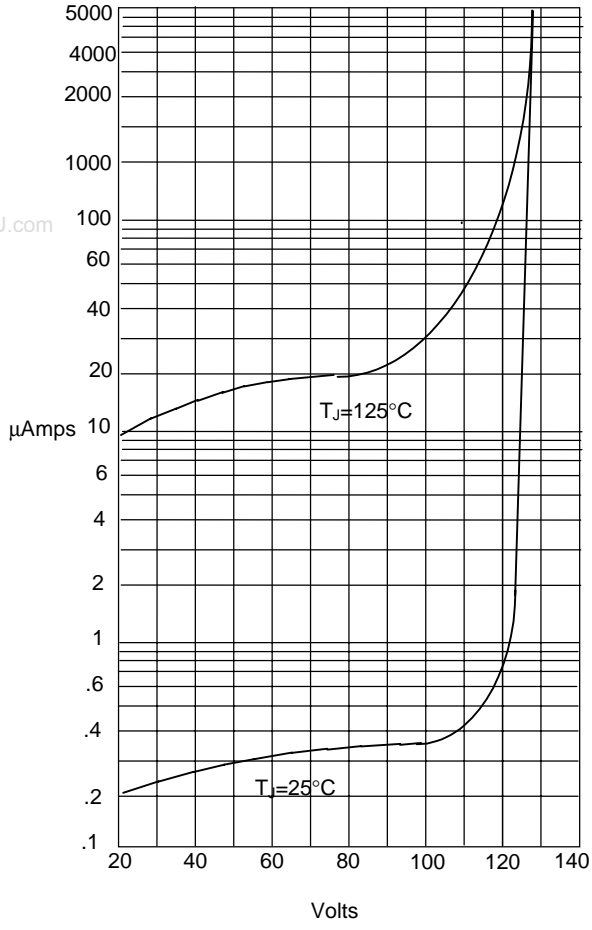
Figure 3
Junction Capacitance



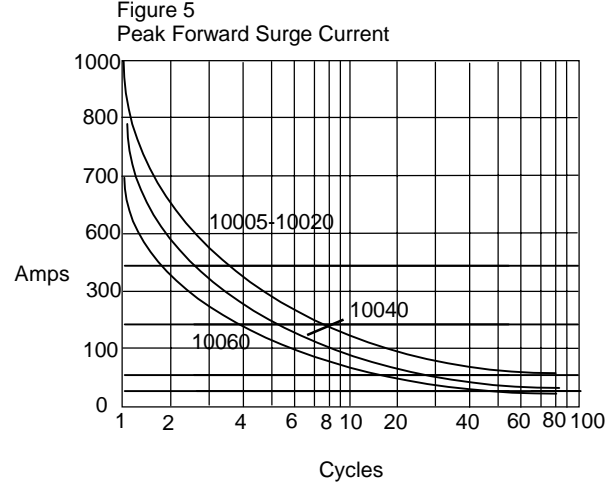
Junction Capacitance - pF versus
Reverse Voltage - Volts



Figure 4
Typical Reverse Characteristics



Instantaneous Reverse Leakage Current - MicroAmperes versus Percent Of Rated Peak Reverse Voltage - Volts



Peak Forward Surge Current - Amperes versus Number Of Cycles At 60Hz - Cycles

www.DataSheet4U.com