

1A High Power LED Driver with 6~36V Input

DESCRIPTION

The SD42522 is a step-down PWM control LED driver with a built-in power MOSFET. It achieves 1A continuous output current in 6~36V input voltage range. It provides thermal shutdown circuit, current limit circuit.

The SD42522 adopts current mode control which provides fast transient response and simple loop stabilization design. It has high efficiency up to more than 96%, and has excellent constant current characteristic when the input/output voltage changed, with the excellent current accuracy within $\pm 1\%$

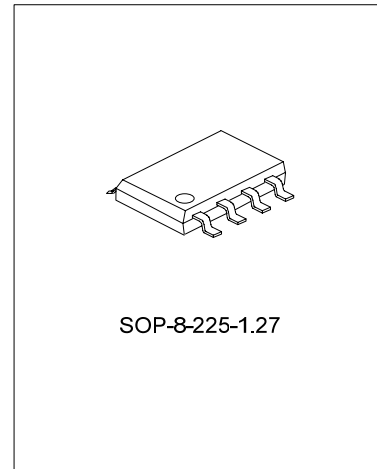

FEATURES

- * 6-36V input voltage range
- * Maximum 1A output current
- * 0.40Ω built-in power MOSFET
- * Integrate Jitter function
- * 280kHz fixed frequency
- * Excellent constant current accuracy $\pm 1\%$
- * High efficiency up to 96%
- * Thermal shutdown
- * Cycle-by-cycle over current protection

APPLICATIONS

- * MR16 LED spotlight
- * LED illuminance
- * LED street lamp

ORDERING INFORMATION

Part No.	Package	Marking	Material	Package Type
SD42522	SOP-8-225-1.27	SD42522	Pb free	Tube
SD42522TR	SOP-8-225-1.27	SD42522	Pb free	Tape & Reel

BLOCK DIAGRAM

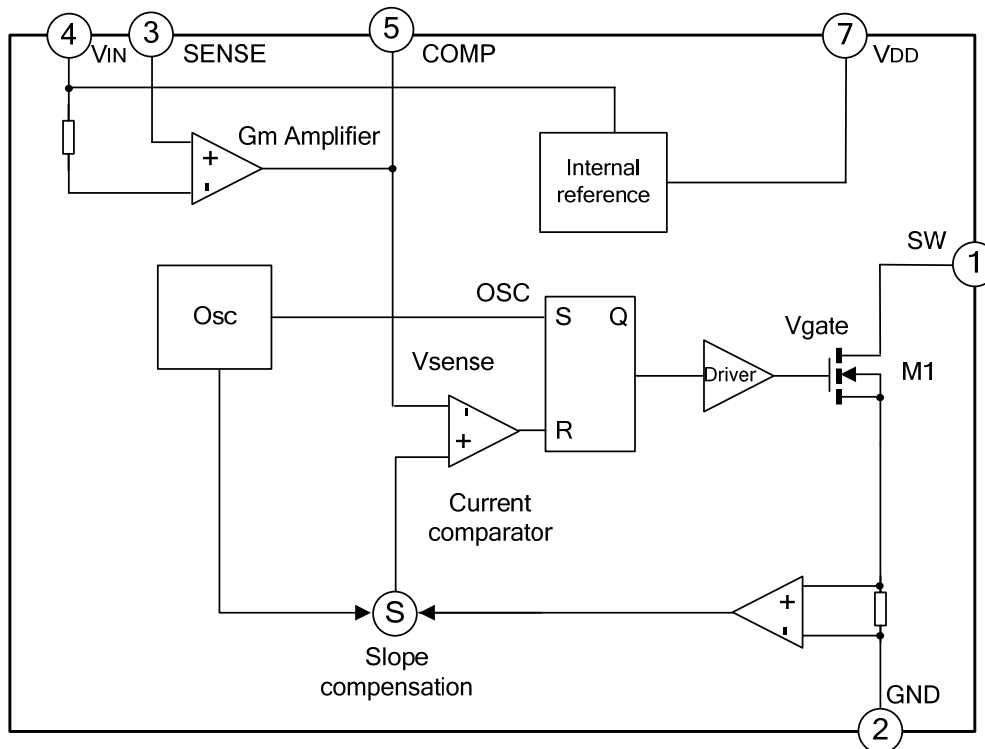

ABSOLUTE MAXIMUM RATING

Characteristics	Symbol	Ratings	Unit
Supply Voltage	V _{IN}	40	V
Switch Voltage	V _{SW}	-1~V _{IN} +1	V
Comp Voltage	V _{COMP}	-0.3~6	V
SENSE voltage	V _{SENSE}	-0.3~V _{IN}	V
Junction Temperature	T _j	150	°C
Lead Temperature	T _L	260	°C
Storage Temperature	T _{STG}	-65~150	°C
Input Voltage	V _{IN}	6~40	V
Operating Temperature	T _{OPR}	-40~125	°C

ELECTRICAL CHARACTERISTICS (Unless otherwise specified, V_{IN}=12V, I_{OUT}=700mA, T_{amb}=25°C)

Characteristics	Symbol	Test Condition	Min.	Typ.	Max.	Unit
Supply Voltage	V _{IN}		6		36	V
Operating Current	I _{IN}	V _{CC} =6/40V		1.5	2.0	mA
Upper Switch Leakage	I _L	V _{SW} =36V		0	5	μA
Current Limit	I _{LIM}	V _{IN} =SENSE=12V	1.6	1.9	2.2	A
Maximum Duty Cycle	D _{max}	3LED, V _{IN} =9V	--	93	95	%
Oscillator Frequency	f _{osc}		250	280	320	kHz

Characteristics	Symbol	Test Condition	Min.	Typ.	Max.	Unit
COMP Clamp Voltage	VCOMP	Open without load	1.6	1.9	2.2	V
Switch Transistor on Resistance	RON	1LED, IOUT=1A	--	0.40	0.6	Ω
VDD voltage	VDD	No load	5.0	5.2	5.4	V
Sampling Voltage Threshold	VIN- VSENSE	Drop voltage between VIN and SENSE	--	88	--	mV
Thermal Shutdown Threshold	TSD			160		$^{\circ}\text{C}$
Thermal Shutdown Hysteresis	TSD-hys			30		$^{\circ}\text{C}$

PIN CONFIGURATION

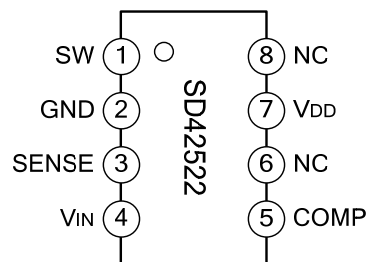

PIN DESCRIPTION

Pin No.	Pin Name	I/O	Description
1	SW	I	Power output.
2	GND	O	Ground.
3	SENSE	I	Current sense pin.
4	VIN	O	Input supply voltage.
5	COMP	I/O	Compensation pin, connects to external capacitor.
6	NC	-	No Connected.
7	VDD	I	5V reference output.
8	NC	-	No Connected.

FUNCTION DESCRIPTION

The SD42522 is a current mode LED driver. The voltage on compensation pin COMP is proportional to the current delivered to the load.

At the beginning of a cycle: the upper transistor M1 is off; the COMP pin voltage is higher than the current sense amplifier output; and the current comparator's output is low. The rising edge of the 280KHz CLK signal sets the RS Flip-Flop whose output turns on M1 thus VIN, Rs, LED, inductor and M1 comprises a circuit loop and the inductor current increases. The inductor current is sensed and amplified by the current sense amplifier. Ramp compensation is summed to current sense amplifier output and compared to the Gm amplifier output by the current comparator. When the current sense amplifier plus ramp compensation signal exceeds the comp pin voltage, the RS Flip-Flop is reset and the chip reverts to its initial M1 off state. The inductor energy storage released via the circuit loop composed by Rs, LED, inductor and M1 and the current decreases. When next clock cycle arrives, the upper transistor M1 is on to enter next switch cycle. If the current sense amplifier plus slope

compensation signal does not exceed the comp voltage in one cycle, then the falling edge of the CLK resets the Flip-Flop.

The Gm amplifier compares the output current with the threshold current (threshold current is set by internal). When the output current is higher than threshold current, the COMP pin's voltage is lower down. Since the COMP pin's voltage is proportional to the peak inductor current a decrease in its voltage decreases current delivered to the output. When the output current is lower than threshold current, the COMP pin's voltage is up while the output current increases. The output current is stable at the set value by adjusting the circuit loop.

1. Output current setting

The output current is determined by the sampling resistor and setting voltage. The sampling voltage of VIN-VSENSE(Drop voltage on Rs) is 88mV, and adjust the output current by adjusting the sampling resistor Rs (refer to Typical Application Circuit).

$$I_{OUT} = \frac{V_{IN} - V_{SENSE}}{R_S}$$

2. Current limiting

SD42522 has internal current limiting function, and the voltage on COMP is clamped at about 1.9V, the output current of the power MOSFET is limited at about 1.9A by current comparator.

3. Frequency jitter

SD42522 has internal frequency jitter function to improve the EMI performance of the system. The internal frequency is hopping in a very small range to reduce the single frequency radiation which simplifies the EMI design.

COMPONENTS SELECTION

1. Input Capacitor Selection

The input capacitor provides the pulse current when the power MOSFET is on, and charge the capacitor when the power MOSFET is off, thus to keep the stability of the input voltage. The input capacitor is recommended to be more than 10 μ F, which can reduce the peak current drawn from input source and the switch noise. The input capacitor should be near to the input pin in real routing.

2. Output Capacitance Selection

Parallel connecting a capacitor between the two ends of LED can reduce the output voltage ripple accordingly reduce the ripple current of LED, while this capacitor will not effect the operating frequency and efficiency, but the start time will be longer by reducing the rising speed of the voltage on LED. The larger the output capacitor is, the smaller the current ripple on LED is. It is recommend use the capacitor of 2.2 μ F or larger.

3. Inductance Selection

The inductance is used to keep the output current constant, the bigger the inductance is, the smaller the output current ripple is; while the bigger the physical size is, the bigger the series-wound resistor is. The selected effective current (RMS current rating)of inductance current should be bigger than the maximum output current, and the saturation current should be 30% bigger than maximum output current. In order to improve the efficiency, the series-wound resistor (DCR) of inductance should be smaller than 0.2 Ω .

The relation between inductance and ripple:

$$L = V_{OUT} * \frac{V_{IN} - V_{OUT}}{V_{IN} * f * \Delta I}$$

Where: L: Inductance value

F: Oscillator frequency

ΔI is ripple current

When select inductance, you should consider the combination of various factors to select suitable inductance.

4. Diode Selection

SD42522 is a non-synchronous step-down adjuster, so the diode should provide continuous current when the power MOSFET is off. Because the forward voltage of Schottky diode is small, and the reverse continuous current time is short, so it is usually used for continuous current. During the power MOSFET is conducting, the diode will withstand high voltage, so the reverse voltage of selected diode should be bigger than the input voltage. The average current through the diode is I_D :

$$I_D = (1-D) * I_{LED}$$

I_{LED} is the current of LED

When the input voltage is high with a small duty, I_D increases, so the selected maximum continuous current diode should be bigger than the output current.

TYPICAL APPLICATION CIRCUIT

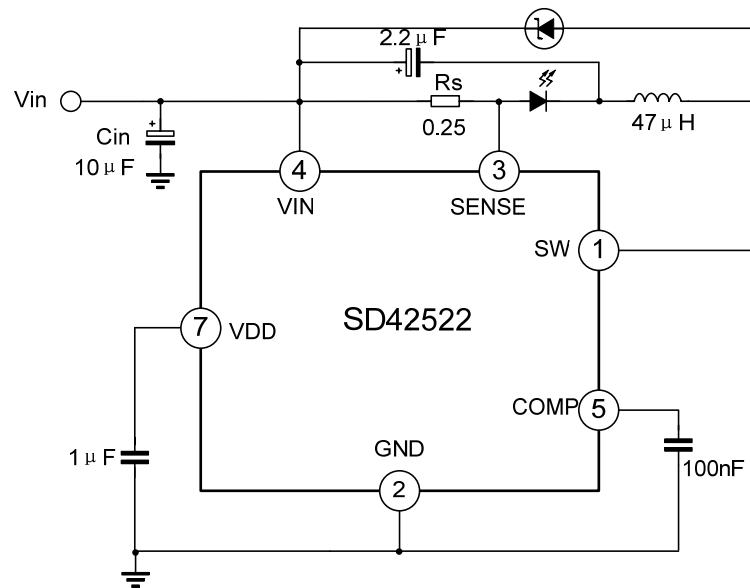

6~36V input voltage, 350mA output LED driver

Note: The circuit and parameters are reference only, please set the parameters of the real application circuit based on the real test .

ELECTRICAL CHARACTERISTICS CURVE

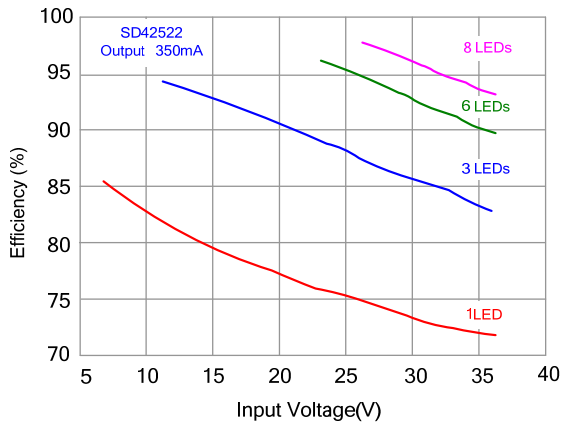

Output 350mA efficiency changed following the input voltage

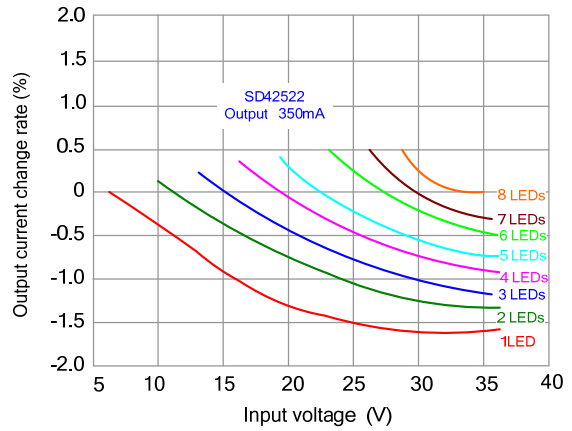

Output 350mA current change rate following the input voltage change

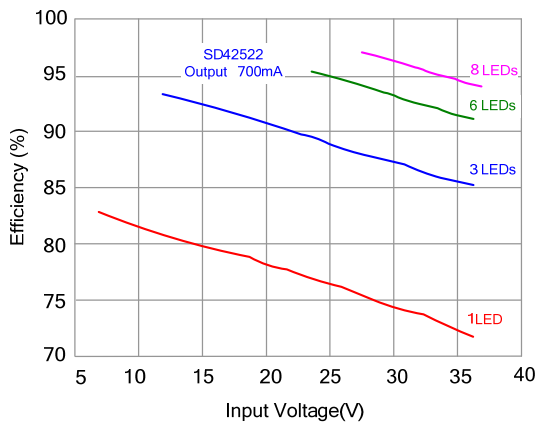

Output 700mA efficiency changed following the input voltage

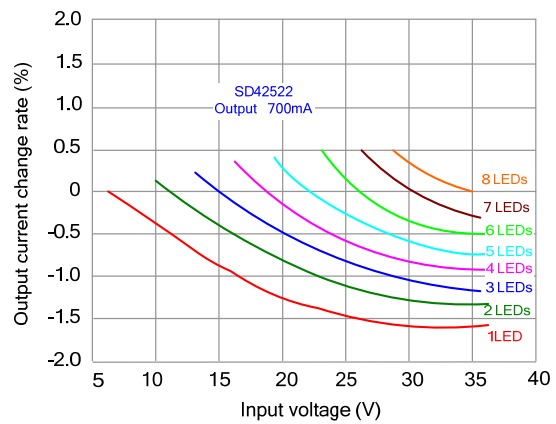

Output 700mA current change rate following the input voltage

www.DataSheet4U.com

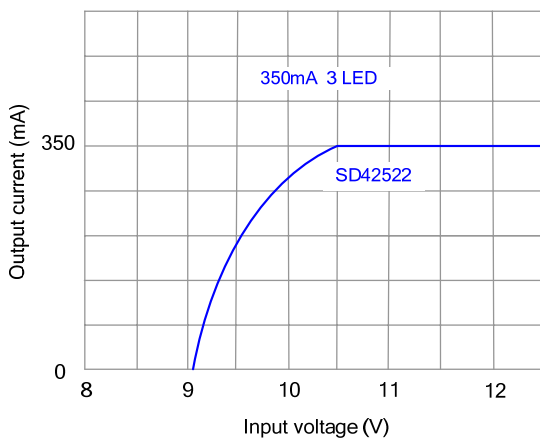

Output current change curve when input voltage is close to output voltage(350mA)

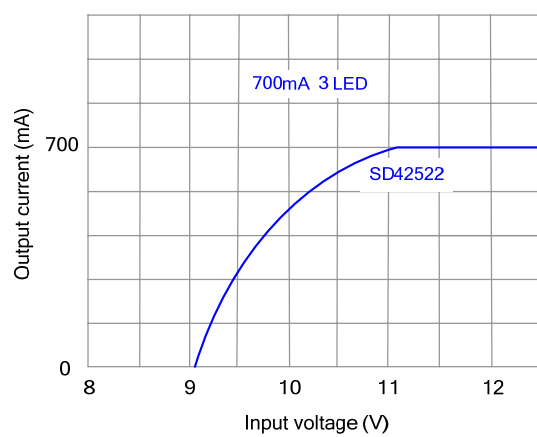

Output current change curve when input voltage is close to output voltage(700mA)

PACKAGE OUTLINE

SOP-8-225-1.27

UNIT: mm

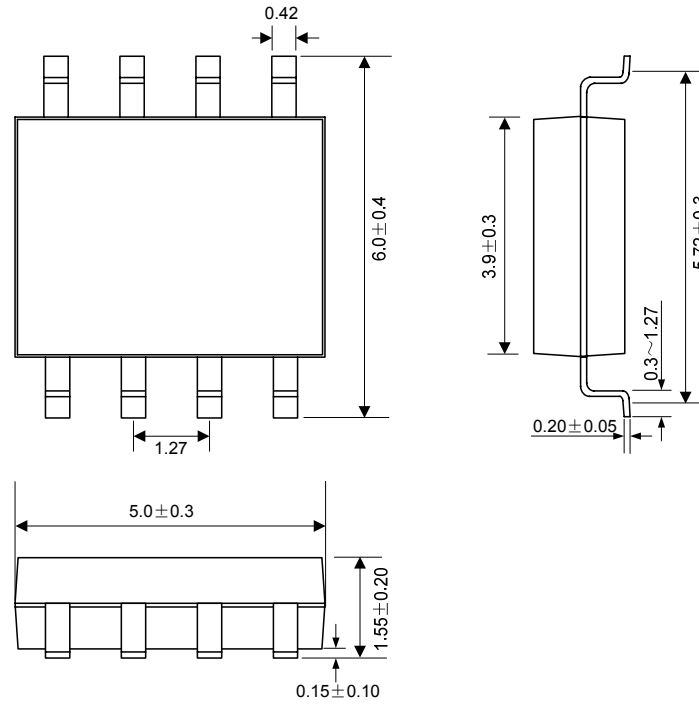

HANDLING MOS DEVICES:

Electrostatic charges can exist in many things. All of our MOS devices are internally protected against electrostatic discharge but they can be damaged if the following precautions are not taken:

- Persons at a work bench should be earthed via a wrist strap.
- Equipment cases should be earthed.
- All tools used during assembly, including soldering tools and solder baths, must be earthed.
- MOS devices should be packed for dispatch in antistatic/conductive containers.

Disclaimer:

- Silan reserves the right to make changes to the information herein for the improvement of the design and performance without further notice!
- All semiconductor products malfunction or fail with some probability under special conditions. When using Silan products in system design or complete machine manufacturing, it is the responsibility of the buyer to comply with the safety standards strictly and take essential measures to avoid situations in which a malfunction or failure of such Silan products could cause loss of body injury or damage to property.
- Silan will supply the best possible product for customers!