

**104-COM-8SM / 104-COM-4SM / 104-COM-2SM****KEY FEATURES:**

8, 4 or 2 independent asynchronous serial COM ports

Field selectable RS-232, RS-422 and RS-485, independent for each port

Auto-RTS feature makes half-duplex RS-485 communications effortless

Speeds up to 921.6K with 64-byte FIFO

Fixed bias and jumper selectable termination provided on each transmit and receive channel simplifies cabling

Programmable individual non-volatile base addresses and IRQs simplifies installation

Low power required: +5VDC at 80mA typical

Operates as a standard COM port in all operating systems

**FACTORY OPTIONS:**

0 to 70°C and -40 to +85°C versions available

128-byte FIFO

The 104-COM-8SM Series are eight, four, or two-port, asynchronous, serial communication boards that support field selectable RS-232/422/485 communication. Ports are accessed via two 40-pin IDC type right angle header connectors. The boards include a convenient Auto-RTS feature, which makes half-duplex RS-485 communications effortless.

The 104-COM-8SM Series are feature-rich and allow for the connection of multiple serial devices—ideal for a variety of applications such as POS, gaming systems, machine monitoring and control, military, high-density networking applications or any other application requiring the connection of RS-232/422/485 serial devices to a PC/104 compatible system.

The 104-COM-8SM Series were designed using type 16780 UARTS and include 64-byte transmit/receive FIFO buffers to protect against lost data in multi-tasking systems while maintaining 100% compatibility with all operating system COM port drivers. A crystal oscillator located on the board permits baud rate capability up to 921.6K. The boards are offered in both standard and extended temperature versions - ideal for outdoor applications or harsh industrial surroundings.

**SOFTWARE**

The 104-COM-8SM Series are supported for use in all operating systems and include a free DOS, Linux and Windows 95/98/Me/NT/2000/XP/2003 compatible software package. This includes sample programs and source code in "C" and Pascal for DOS, and Visual Basic, Delphi, C++ Builder, and Visual C++ for Windows. Also included is a graphical setup program in Windows. Embedded OS support includes Windows XPe and CE. An easy-to-use Windows terminal program simplifies verification of proper operation.

## 104-COM-8SM / 104-COM-4SM / 104-COM-2SM

### Block Diagram & Pin Configuration

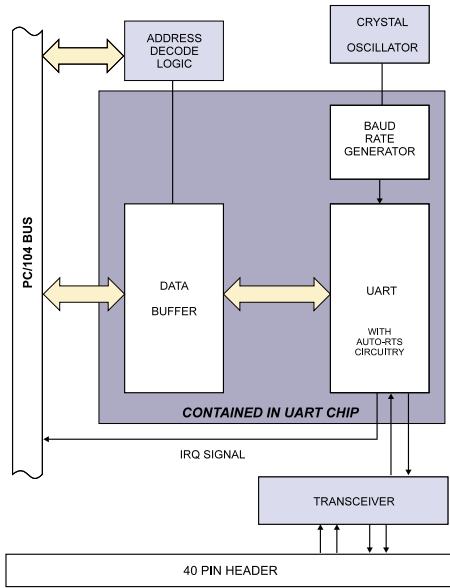

#### RS-232 Functions

PORT0-DCD	01	02	PORT0-DSR
PORT0-Rx	03	04	PORT0-RTS
PORT0-Tx	05	06	PORT0-CTS
PORT0-DTR	07	08	PORT0-RI
PORT0-GND	09	10	NC
PORT1-DCD	11	12	PORT1-DSR
PORT1-Rx	13	14	PORT1-RTS
PORT1-Tx	15	16	PORT1-CTS
PORT1-DTR	17	18	PORT1-RI
PORT1-GND	19	20	NC
PORT2-DCD	21	22	PORT2-DSR
PORT2-Rx	23	24	PORT2-RTS
PORT2-Tx	25	26	PORT2-CTS
PORT2-DTR	27	28	PORT2-RI
PORT2-GND	29	30	NC
PORT3-DCD	31	32	PORT3-DSR
PORT3-Rx	33	34	PORT3-RTS
PORT3-Tx	35	36	PORT3-CTS
PORT3-DTR	37	38	PORT3-RI
PORT3-GND	39	40	NC

#### RS-422 Functions

NC	01	02	NC
PORT0-Tx+	03	04	PORT0-Tx-
NC	05	06	PORT0-Rx+
PORT0-Rx+	07	08	NC
PORT0-GND	09	10	NC
NC	11	12	NC
PORT1-Tx+	13	14	PORT1-Tx-
NC	15	16	PORT1-Rx+
PORT1-Rx+	17	18	NC
PORT1-GND	19	20	NC
NC	21	22	NC
PORT2-Tx+	23	24	PORT2-Tx-
NC	25	26	PORT2-Rx+
PORT2-Rx+	27	28	NC
PORT2-GND	29	30	NC
NC	31	32	PORT3-Tx+
PORT3-Tx+	33	34	NC
PORT3-Rx+	35	36	PORT3-Rx+
NC	37	38	NC
PORT3-GND	39	40	NC

#### RS-485 Functions

NC	01	02	NC
PORT0-Tx/Rx+	03	04	PORT0-Tx/Rx-
NC	05	06	NC
PORT0-Rx+	07	08	NC
PORT0-GND	09	10	NC
NC	11	12	NC
PORT1-Tx/Rx+	13	14	PORT1-Tx/Rx-
NC	15	16	NC
PORT1-Rx+	17	18	NC
PORT1-GND	19	20	NC
NC	21	22	NC
PORT2-Tx/Rx+	23	24	PORT2-Tx/Rx-
NC	25	26	NC
PORT2-Rx+	27	28	NC
PORT2-GND	29	30	NC
NC	31	32	PORT3-Tx+
PORT3-Tx/Rx+	33	34	NC
NC	35	36	NC
PORT3-Rx+	37	38	NC
PORT3-GND	39	40	NC

## Specifications

### Serial Ports

Number of serial ports	8, 4, or 2
Protocol	Full RS-232, RS-422 and RS-485, independent for each port
Maximum baud rate	921.6K
Character length	5, 6, 7, or 8 data bits
Parity	Even, odd, or none
Receiver input sensitivity	±200mV differential input. Lines include factory bias and jumper selectable termination.
Common mode voltage range	+12V to -7V
Transmitter output drive capability	60mA with thermal shutdown. Lines include factory bias and jumper selectable termination.
Base address options	Programmable
Interrupts	Individual IRQs for each channel are stored onboard in non-volatile memory

### General

I/O connections	Via two 40 pin IDC type right angle connectors. There are eight pins per port plus common grounds.
Short circuit protection	All outputs protected against continuous short circuit
Power required	+5VDC at 80mA typical, all outputs open
Operating temperature	-40 to +85°C optional, all versions
Operating humidity	5% to 95% RH, non-condensing
PC/104 bus	8-bit and 16-bit bus headers are used

## Ordering Guide

104-COM-8SM	8-port RS-232/422/485
104-COM-4SM	4-port RS-232/422/485
104-COM-2SM	2-port RS-232/422/485