

CS2841B

Automotive Current Mode PWM Control Circuit

The CS2841B provides all the necessary features to implement off-line fixed frequency current-mode control with a minimum number of external components.

The CS2841B (a variation of the CS2843A) is designed specifically for use in automotive operation. The low start threshold voltage of 8.0 V (typ), and the ability to survive 40 V automotive load dump transients are important for automotive subsystem designs. The CS2841 series has a history of quality and reliability in automotive applications.

The CS2841B incorporates a precision temperature-controlled oscillator with an internally trimmed discharge current to minimize variations in frequency. Duty-cycles greater than 50% are also possible. On board logic ensures that V_{REF} is stabilized before the output stage is enabled. Ion implant resistors provide tighter control of undervoltage lockout.

Features

- Optimized for Off-Line Control
- Internally Trimmed Temperature Compensated Oscillator
- Maximum Duty-Cycle Clamp
- V_{REF} Stabilized Before Output Stage Enabled
- Low Start-Up Current
- Pulse-By-Pulse Current Limiting
- Improved Undervoltage Lockout
- Double Pulse Suppression
- 1.0 % Trimmed Bandgap Reference
- High Current Totem Pole Output



ON Semiconductor®

<http://onsemi.com>

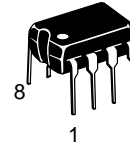

**DIP-8
N SUFFIX
CASE 626**

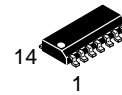

**SO-14
D SUFFIX
CASE 751A**

PIN CONNECTIONS AND MARKING DIAGRAM

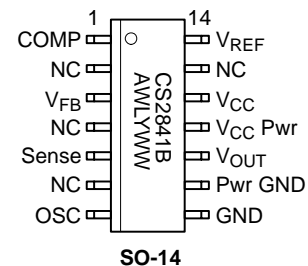
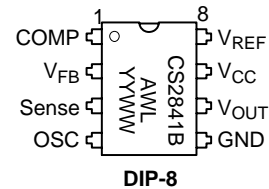

A = Assembly Location
 WL, L = Wafer Lot
 YY, Y = Year
 WW, W = Work Week

ORDERING INFORMATION

Device	Package	Shipping
CS2841BEN8	DIP-8	50 Units/Rail
CS2841BED14	SO-14	55 Units/Rail
CS2841BEDR14	SO-14	2500 Tape & Reel

CS2841B

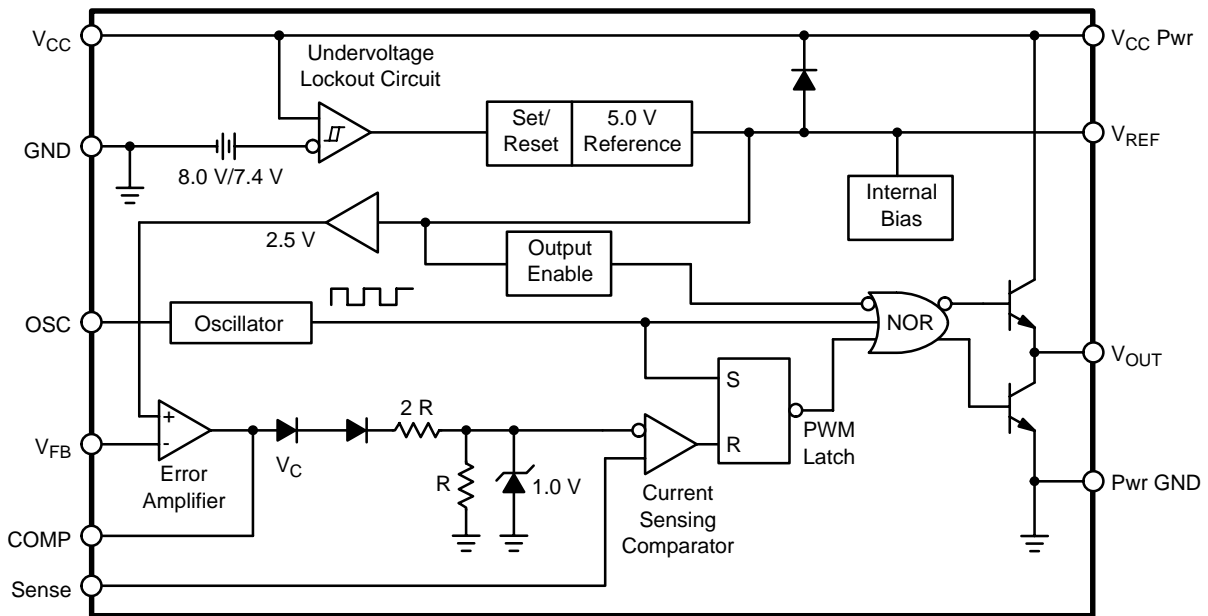

Figure 1. Block Diagram

MAXIMUM RATINGS*

Rating	Value	Unit	
Supply Voltage (Low Impedance Source)	40	V	
Output Current	±1.0	A	
Output Energy (Capacitive Load)	5.0	μJ	
Analog Inputs (V _{FB} , Sense)	-0.3 to 5.5	V	
Error Amp Output Sink Current	10	mA	
Lead Temperature Soldering	Wave Solder (through hole styles only) Note 1 Reflow (SMD styles only) Note 2	260 peak 230 peak	°C °C

1. 10 seconds max.

2. 60 seconds max above 183°C

*The maximum package power dissipation must be observed.

CS2841B

ELECTRICAL CHARACTERISTICS (-40 °C ≤ T_A ≤ 85°C, R_T = 680 kΩ, C_T = 0.022 μF for Triangular Mode, V_{CC} = 15 V (Note 3), R_T = 10 kΩ, C_T = 3.3 nF for Sawtooth Mode (see Figure 7); unless otherwise specified.)

Characteristic	Test Conditions	Min	Typ	Max	Unit
----------------	-----------------	-----	-----	-----	------

Reference Section

Output Voltage	T _J = 25°C, I _{OUT} = 1.0 mA	4.9	5.0	5.1	V
Line Regulation	8.4 ≤ V _{CC} ≤ 16 V	-	6.0	20	mV
Load Regulation	1.0 ≤ I _{OUT} ≤ 20 mA	-	6.0	25	mV
Temperature Stability	Note 4	-	0.2	0.4	mV/°C
Total Output Variation	Line, Load, Temp. Note 4	4.82	-	5.18	V
Output Noise Voltage	10 Hz ≤ f ≤ 10 kHz, T _J = 25°C. Note 4	-	50	-	μV
Long Term Stability	T _A = 125°C, 1000 Hrs. Note 4	-	5.0	25	mV
Output Short Circuit	T _A = 25°C	-30	-100	-180	mA

Oscillator Section

Initial Accuracy	Sawtooth Mode: T _J = 25°C. See Figure 7.	47	52	57	kHz
	Sawtooth Mode: -40°C ≤ T _A ≤ +85°C	44	52	60	kHz
	Triangular Mode: T _J = 25°C. See Figure 7.	44	52	60	kHz
Voltage Stability	8.4 ≤ V _{CC} ≤ 16 V	-	0.2	1.0	%
Temperature Stability	Sawtooth Mode: T _{MIN} ≤ T _A ≤ T _{MAX} . Note 4	-	5.0	-	%
	Triangular Mode: T _{MIN} ≤ T _A ≤ T _{MAX} . Note 4	-	8.0	-	%
Amplitude	V _{OSC} (Peak to Peak)	-	1.7	-	V
Discharge Current	T _J = 25°C	7.4	8.3	9.2	mA
	T _{MIN} ≤ T _A ≤ T _{MAX}	7.2	-	9.4	mA

Error Amp Section

Input Voltage	V _{COMP} = 2.5 V	2.42	2.5	2.58	V
Input Bias Current	V _{FB} = 0 V	-	-0.3	-2.0	μA
A _{VOL}	2.0 ≤ V _{OUT} ≤ 4.0 V	65	90	-	dB
Unity Gain Bandwidth	Note 4	0.7	1.0	-	MHz
PSRR	8.4 V ≤ V _{CC} ≤ 16 V	60	70	-	dB
Output Sink Current	V _{FB} = 2.7 V, V _{COMP} = 1.1 V	2.0	6.0	-	mA
Output Source Current	V _{FB} = 2.3 V, V _{COMP} = 5.0 V	-0.5	-0.8	-	mA
V _{OUT} High	V _{FB} = 2.3 V, R _L = 15 kΩ to Ground	5.0	6.0	-	V
V _{OUT} Low	V _{FB} = 2.7 V, R _L = 15 kΩ to V _{REF}	-	0.7	1.1	V

Current Sense Section

Gain	Notes 5 and 6	2.85	3.0	3.15	V/V
Maximum Input Signal	V _{COMP} = 5.0 V. Note 5	0.9	1.0	1.1	V
PSRR	12 V ≤ V _{CC} ≤ 25 V. Note 5	-	70	-	dB
Input Bias Current	V _{Sense} = 0 V	-	-2.0	-10	μA
Delay to Output	T _J = 25°C. Note 4	-	150	300	ns

- Adjust V_{CC} above the start threshold before setting at 15 V.
- These parameters, although guaranteed, are not 100% tested in production.
- Parameter measured at trip point of latch with V_{FB} = 0.
- Gain defined as:

$$A = \frac{\Delta V_{COMP}}{\Delta V_{Sense}}; 0 \leq V_{Sense} \leq 0.8 \text{ V.}$$

CS2841B

ELECTRICAL CHARACTERISTICS (continued) ($-40^{\circ}\text{C} \leq T_A \leq 85^{\circ}\text{C}$, $R_T = 680\text{ k}\Omega$, $C_T = 0.022\text{ }\mu\text{F}$ for Triangular Mode, $V_{CC} = 15\text{ V}$ (Note 3), $R_T = 10\text{ k}\Omega$, $C_T = 3.3\text{ nF}$ for Sawtooth Mode (see Figure 7); unless otherwise specified.)

Characteristic	Test Conditions	Min	Typ	Max	Unit
----------------	-----------------	-----	-----	-----	------

Output Section

Output Low Level	$I_{\text{SINK}} = 20\text{ mA}$	-	0.1	0.4	V
	$I_{\text{SINK}} = 200\text{ mA}$	-	1.5	2.2	V
Output High Level	$I_{\text{SOURCE}} = 20\text{ mA}$	13	13.5	-	V
	$I_{\text{SOURCE}} = 200\text{ mA}$	12	13.5	-	V
Rise Time	$T_J = 25^{\circ}\text{C}$, $C_L = 1.0\text{ nF}$. Note 7	-	50	150	ns
Fall Time	$T_J = 25^{\circ}\text{C}$, $C_L = 1.0\text{ nF}$. Note 7	-	50	150	ns
Output Leakage	Undervoltage Active, $V_{\text{OUT}} = 0$	-	-0.01	-10	μA

Total Standby Current

Start-Up Current	-	-	0.5	1.0	mA
Operating Supply Current I_{CC}	$V_{\text{FB}} = V_{\text{Sense}} = 0\text{ V}$, $R_T = 10\text{ k}\Omega$, $C_T = 3.3\text{ nF}$	-	11	17	mA

Undervoltage Lockout Section

Start Threshold	-	7.6	8.0	8.4	V
Min. Operating Voltage	After Turn On	7.0	7.4	7.8	V

7. These parameters, although guaranteed, are not 100% tested in production.

PACKAGE PIN DESCRIPTION

PACKAGE PIN #		PIN SYMBOL	FUNCTION
DIP-8	SO-14		
1	1	COMP	Error amp output, used to compensate error amplifier.
2	3	V_{FB}	Error amp inverting input.
3	5	Sense	Noninverting input to Current Sense Comparator.
4	7	OSC	Oscillator timing network with Capacitor to Ground, resistor to V_{REF} .
5	8	GND	Ground.
	9	Pwr GND	Output driver Ground.
6	10	V_{OUT}	Output drive pin.
	11	$V_{\text{CC Pwr}}$	Output driver positive supply.
7	12	V_{CC}	Positive power supply.
8	14	V_{REF}	Output of 5.0 V internal reference.
	2, 4, 6, 13	NC	No connection.

CS2841B

TYPICAL PERFORMANCE CHARACTERISTICS

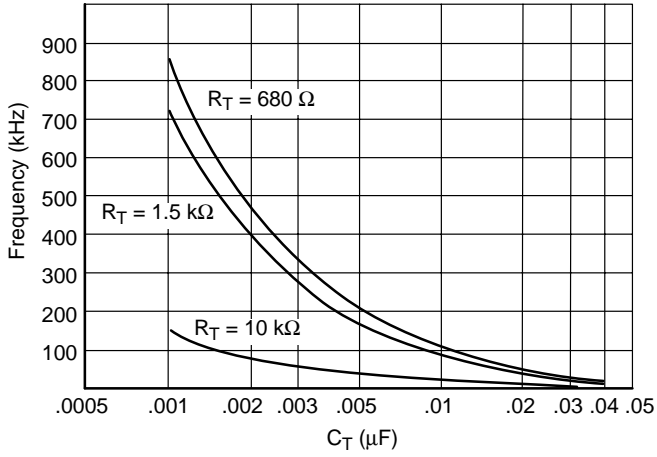

Figure 2. Oscillator Frequency vs. C_T

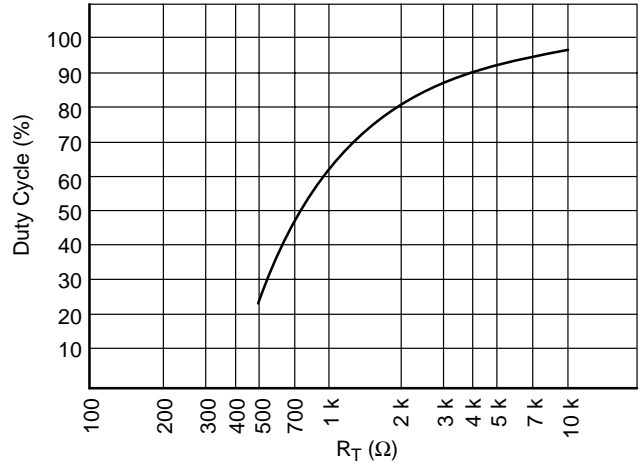

Figure 3. Oscillator Duty Cycle vs. R_T

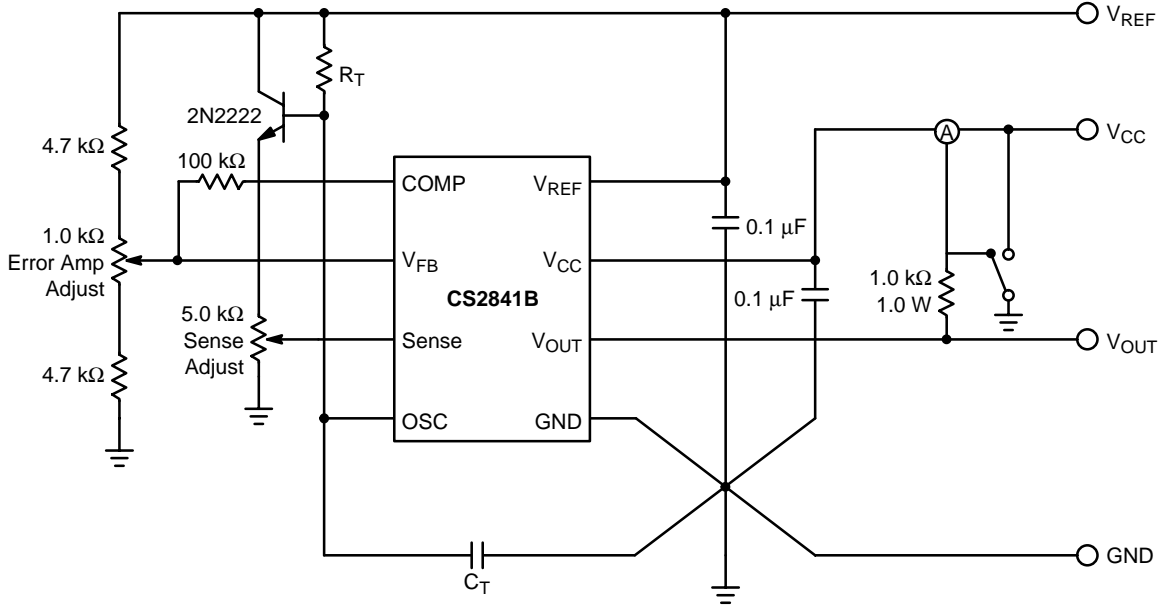

Figure 4. Test Circuit

CIRCUIT DESCRIPTION

Undervoltage Lockout

During Undervoltage Lockout (Figure 5), the output driver is biased to a high impedance state. The output should be shunted to ground with a resistor to prevent output leakage current from activating the power switch.

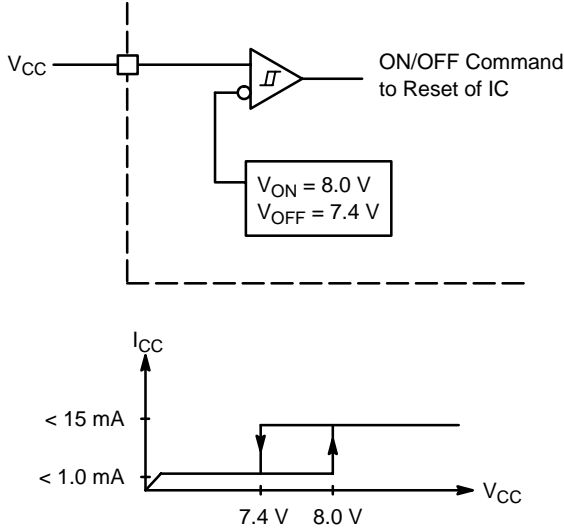

Figure 5. Typical Undervoltage Characteristics

PWM Waveform

To generate the PWM waveform, the control voltage from the error amplifier is compared to a current sense signal which represents the peak output inductor current (Figure 6). An increase in V_{CC} causes the inductor current slope to increase, thus reducing the duty cycle. This is an inherent feed-forward characteristic of current mode control, since the control voltage does not have to change during changes of input supply voltage.

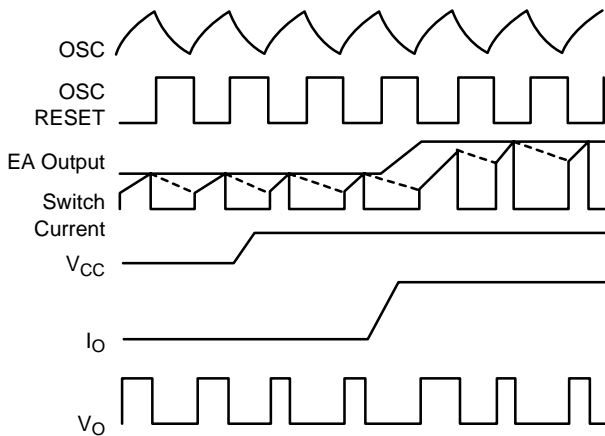
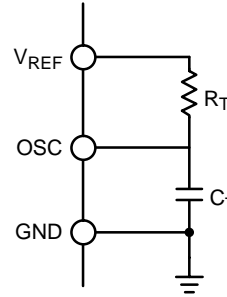
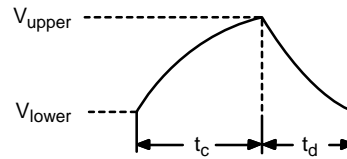

Figure 6. Timing Diagram for Key CS2841B Parameters

When the power supply sees a sudden large output current increase, the control voltage will increase allowing the duty cycle to momentarily increase. Since the duty cycle tends to exceed the maximum allowed to prevent transformer saturation in some power supplies, the internal oscillator waveform provides the maximum duty cycle clamp as programmed by the selection of OSC components.



Timing Parameters



Sawtooth Mode

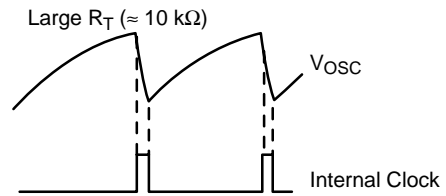

Triangular Mode

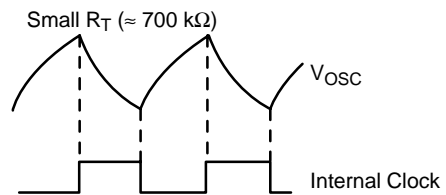

Figure 7. Oscillator Timing Network and Parameters

Setting the Oscillator

Oscillator timing capacitor, C_T , is charged by V_{REF} through R_T and discharged by an internal current source. During the discharge time, the internal clock signal blanks out the output to the Low state, thus providing a user selected maximum duty cycle clamp. Charge and discharge times are determined by the general formulas:

CS2841B

$$t_c = R_T C_T \ln \left(\frac{V_{REF} - V_{lower}}{V_{REF} - V_{upper}} \right)$$

$$t_d = R_T C_T \ln \left(\frac{V_{REF} - I_d R_T - V_{upper}}{V_{REF} - I_d R_T - V_{lower}} \right)$$

Substituting in typical values for the parameters in the above formulas:

$$V_{REF} = 5.0 \text{ V}$$

$$V_{upper} = 2.7 \text{ V}$$

$$V_{lower} = 1.0 \text{ V}$$

$$I_d = 8.3 \text{ mA}$$

$$t_c \approx 0.5534 R_T C_T$$

The frequency and maximum duty cycle can be determined from the Typical Performance Characteristic graphs.

Grounding

High peak currents associated with capacitive loads necessitate careful grounding techniques. Timing and bypass capacitors should be connected close to GND pin in a single point ground.

The transistor and 5.0 kΩ potentiometer are used to sample the oscillator waveform and apply an adjustable ramp to Sense.

$$t_d = R_T C_T \ln \left(\frac{2.3 - 0.0083 R_T}{4.0 - 0.0083 R_T} \right)$$

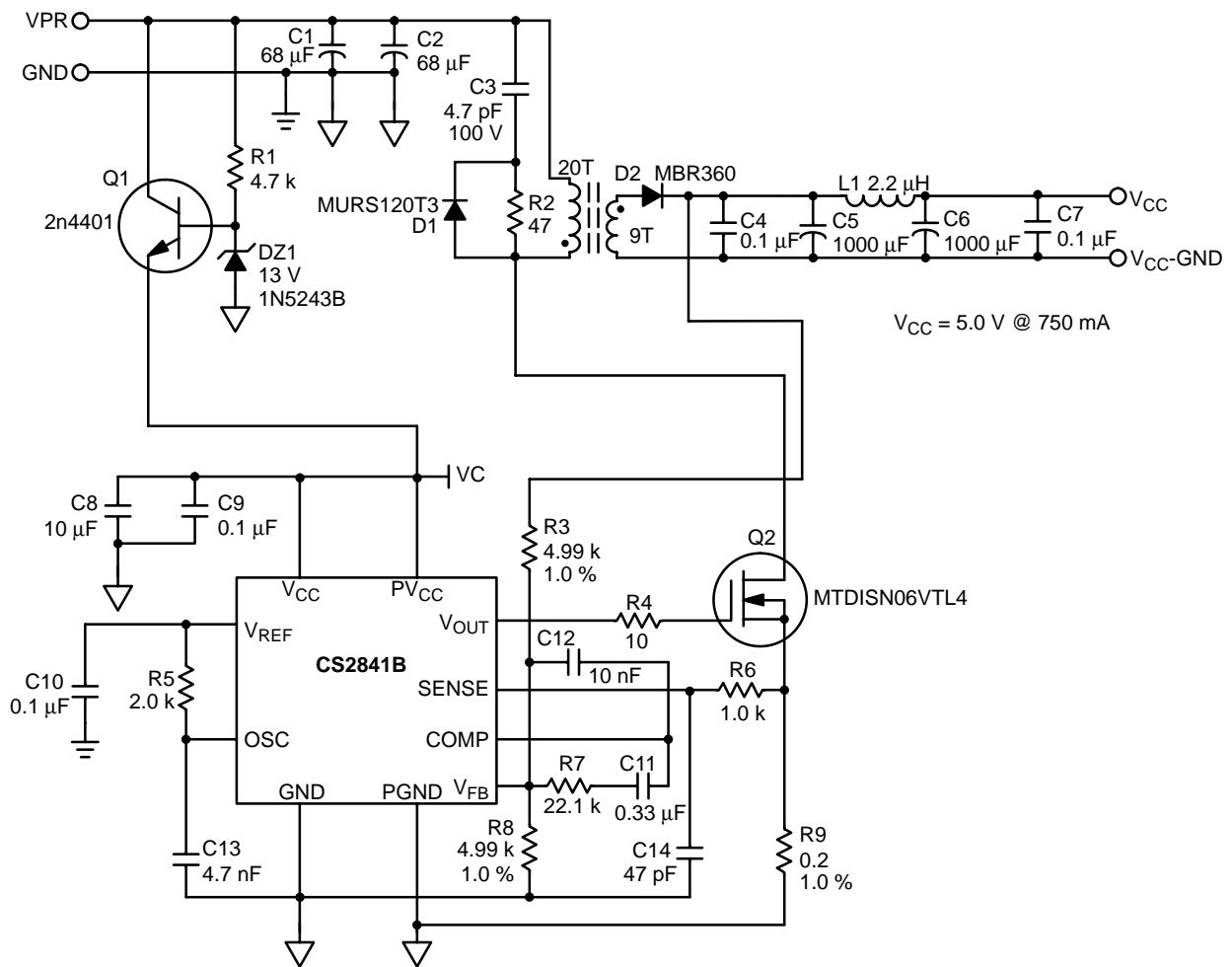
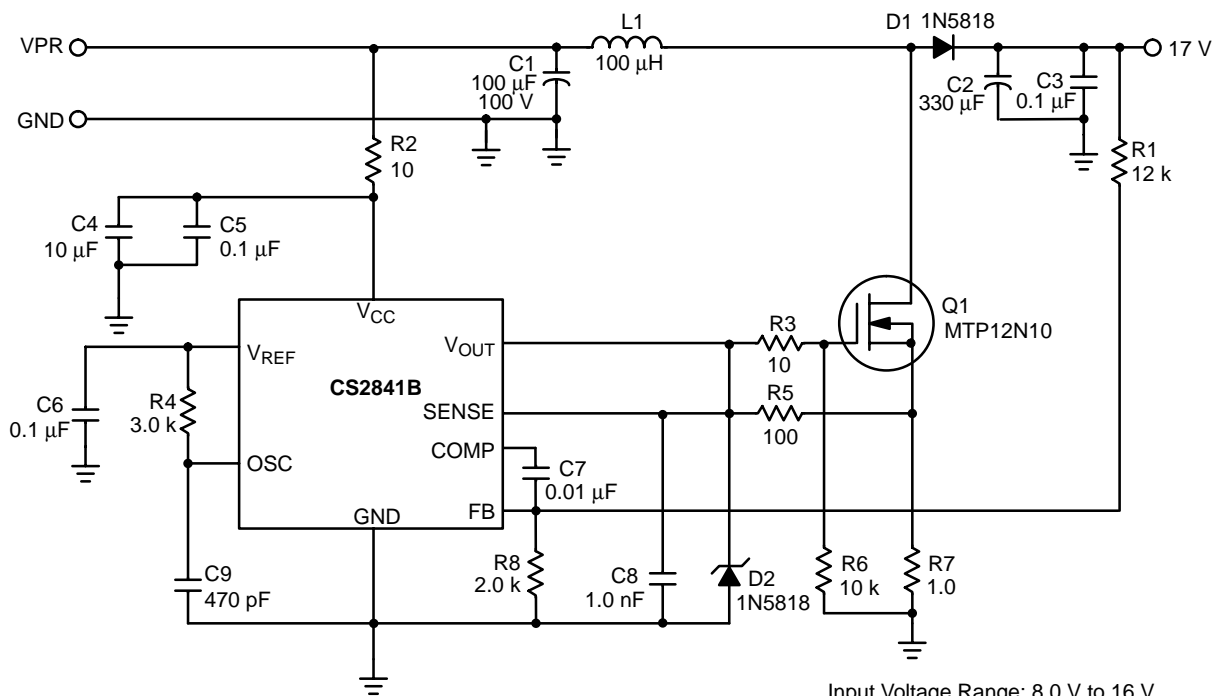

Figure 8. Flyback Application

CS2841B



Input Voltage Range: 8.0 V to 16 V
Output Voltage: 17 V @ 100 mA > 300 mA

Figure 9. Boost Application

CS2841B

PACKAGE DIMENSIONS

DIP-8
N SUFFIX
CASE 626-05
ISSUE L

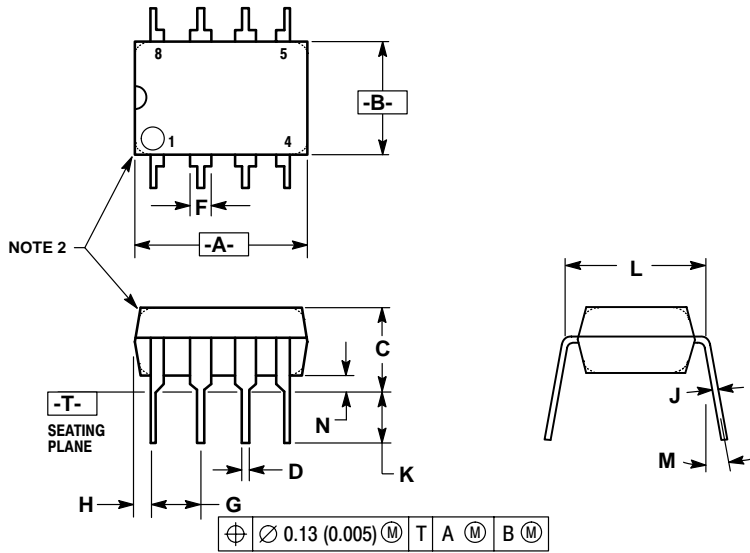

NOTES:

1. DIMENSION L TO CENTER OF LEAD WHEN FORMED PARALLEL.
2. PACKAGE CONTOUR OPTIONAL (ROUND OR SQUARE CORNERS).
3. DIMENSIONING AND TOLERANCING PER ANSI Y14.5M, 1982.

DIM	MILLIMETERS		INCHES	
	MIN	MAX	MIN	MAX
A	9.40	10.16	0.370	0.400
B	6.10	6.60	0.240	0.260
C	3.94	4.45	0.155	0.175
D	0.38	0.51	0.015	0.020
F	1.02	1.78	0.040	0.070
G	2.54 BSC		0.100 BSC	
H	0.76	1.27	0.030	0.050
J	0.20	0.30	0.008	0.012
K	2.92	3.43	0.115	0.135
L	7.62 BSC		0.300 BSC	
M	---		10°	
N	0.76	1.01	0.030	0.040

SO-14
D SUFFIX
CASE 751A-03
ISSUE F

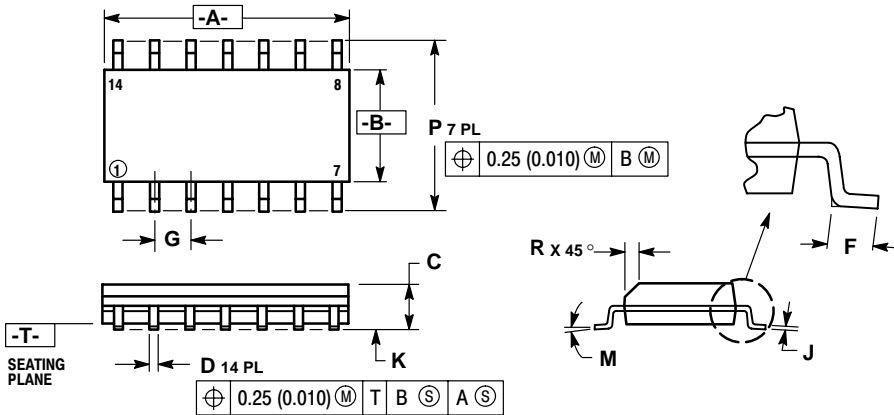

NOTES:

1. DIMENSIONING AND TOLERANCING PER ANSI Y14.5M, 1982.
2. CONTROLLING DIMENSION: MILLIMETER.
3. DIMENSIONS A AND B DO NOT INCLUDE MOLD PROTRUSION.
4. MAXIMUM MOLD PROTRUSION 0.15 (0.006) PER SIDE.
5. DIMENSION D DOES NOT INCLUDE DAMBAR PROTRUSION. ALLOWABLE DAMBAR PROTRUSION SHALL BE 0.127 (0.005) TOTAL IN EXCESS OF THE D DIMENSION AT MAXIMUM MATERIAL CONDITION.

DIM	MILLIMETERS		INCHES	
	MIN	MAX	MIN	MAX
A	8.55	8.75	0.337	0.344
B	3.80	4.00	0.150	0.157
C	1.35	1.75	0.054	0.068
D	0.35	0.49	0.014	0.019
F	0.40	1.25	0.016	0.049
G	1.27 BSC		0.050 BSC	
J	0.19	0.25	0.008	0.009
K	0.10	0.25	0.004	0.009
M	0°		7°	
P	5.80	6.20	0.228	0.244
R	0.25	0.50	0.010	0.019

PACKAGE THERMAL DATA

Parameter		DIP-8	SO-14	Unit
$R_{\theta JC}$	Typical	52	30	°C/W
$R_{\theta JA}$	Typical	100	125	°C/W

ON Semiconductor and  are registered trademarks of Semiconductor Components Industries, LLC (SCILLC). SCILLC reserves the right to make changes without further notice to any products herein. SCILLC makes no warranty, representation or guarantee regarding the suitability of its products for any particular purpose, nor does SCILLC assume any liability arising out of the application or use of any product or circuit, and specifically disclaims any and all liability, including without limitation special, consequential or incidental damages. "Typical" parameters which may be provided in SCILLC data sheets and/or specifications can and do vary in different applications and actual performance may vary over time. All operating parameters, including "Typicals" must be validated for each customer application by customer's technical experts. SCILLC does not convey any license under its patent rights nor the rights of others. SCILLC products are not designed, intended, or authorized for use as components in systems intended for surgical implant into the body, or other applications intended to support or sustain life, or for any other application in which the failure of the SCILLC product could create a situation where personal injury or death may occur. Should Buyer purchase or use SCILLC products for any such unintended or unauthorized application, Buyer shall indemnify and hold SCILLC and its officers, employees, subsidiaries, affiliates, and distributors harmless against all claims, costs, damages, and expenses, and reasonable attorney fees arising out of, directly or indirectly, any claim of personal injury or death associated with such unintended or unauthorized use, even if such claim alleges that SCILLC was negligent regarding the design or manufacture of the part. SCILLC is an Equal Opportunity/Affirmative Action Employer.

PUBLICATION ORDERING INFORMATION

Literature Fulfillment:

Literature Distribution Center for ON Semiconductor
P.O. Box 5163, Denver, Colorado 80217 USA
Phone: 303-675-2175 or 800-344-3860 Toll Free USA/Canada
Fax: 303-675-2176 or 800-344-3867 Toll Free USA/Canada
Email: ONlit@hibbertco.com

N. American Technical Support: 800-282-9855 Toll Free USA/Canada

JAPAN: ON Semiconductor, Japan Customer Focus Center
2-9-1 Kamimeguro, Meguro-ku, Tokyo, Japan 153-0051
Phone: 81-3-5773-3850

ON Semiconductor Website: <http://onsemi.com>

For additional information, please contact your local Sales Representative.