

FEATURES

- Voltage Noise
 - 1.1nV/ $\sqrt{\text{Hz}}$ Max at 1kHz
 - 0.85nV/ $\sqrt{\text{Hz}}$ Typ at 1kHz
 - 1.0nV/ $\sqrt{\text{Hz}}$ Typ at 10Hz
 - 35nV_{P-P} Typ, 0.1Hz to 10Hz
- Voltage and Current Noise 100% Tested
- Gain-Bandwidth Product
 - LT1028: 50MHz Min
 - LT1128: 13MHz Min
- Slew Rate
 - LT1028: 11V/ μs Min
 - LT1128: 5V/ μs Min
- Offset Voltage: 40 μV Max
- Drift with Temperature: 0.8 $\mu\text{V}/^\circ\text{C}$ Max
- Voltage Gain: 7 Million Min
- Available in 8-Pin SO Package

APPLICATIONS

- Low Noise Frequency Synthesizers
- High Quality Audio
- Infrared Detectors
- Accelerometer and Gyro Amplifiers
- 350 Ω Bridge Signal Conditioning
- Magnetic Search Coil Amplifiers
- Hydrophone Amplifiers

DESCRIPTION

The LT[®]1028 (gain of -1 stable)/LT1128 (gain of +1 stable) achieve a new standard of excellence in noise performance with 0.85nV/ $\sqrt{\text{Hz}}$ 1kHz noise, 1.0nV/ $\sqrt{\text{Hz}}$ 10Hz noise. This ultralow noise is combined with excellent high speed specifications (gain-bandwidth product is 75MHz for LT1028, 20MHz for LT1128), distortion-free output, and true precision parameters (0.1 $\mu\text{V}/^\circ\text{C}$ drift, 10 μV offset voltage, 30 million voltage gain). Although the LT1028/LT1128 input stage operates at nearly 1mA of collector current to achieve low voltage noise, input bias current is only 25nA.

The LT1028/LT1128's voltage noise is less than the noise of a 50 Ω resistor. Therefore, even in very low source impedance transducer or audio amplifier applications, the LT1028/LT1128's contribution to total system noise will be negligible.

 LTC and LT are registered trademarks of Linear Technology Corporation

TYPICAL APPLICATION

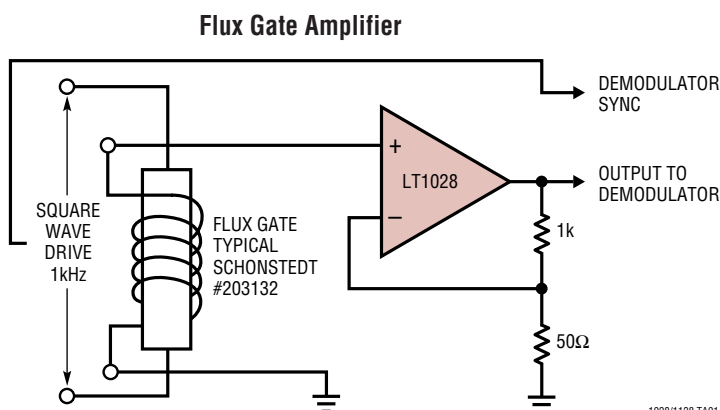

1028/1128 TA01

Voltage Noise vs Frequency

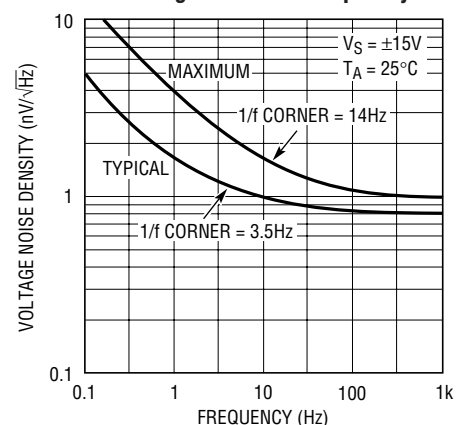

1028/1128 TA02

LT1028/LT1128

ABSOLUTE MAXIMUM RATINGS (Note 1)

Supply Voltage
 -55°C to 105°C ±22V
 105°C to 125°C ±16V
 Differential Input Current (Note 9) ±25mA
 Input Voltage Equal to Supply Voltage
 Output Short Circuit Duration Indefinite

Operating Temperature Range
 LT1028/LT1128AM, M (**OBSOLETE**) -55°C to 125°C
 LT1028/LT1128AC, C (Note 11) -40°C to 85°C
 Storage Temperature Range
 All Devices -65°C to 150°C
 Lead Temperature (Soldering, 10 sec.) 300°C

PACKAGE/ORDER INFORMATION

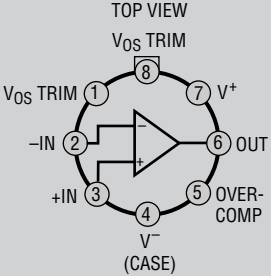
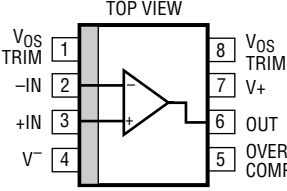
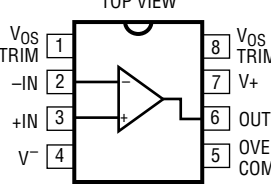
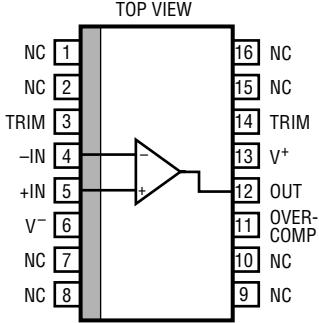
 <p>H PACKAGE 8-LEAD TO-5 METAL CAN $T_{JMAX} = 175^{\circ}\text{C}$, $\theta_{JA} = 140^{\circ}\text{C/W}$, $\theta_{JC} = 40^{\circ}\text{C/W}$</p> <p>OBSOLETE PACKAGE Consider S8 or N8 Packages for Alternate Source</p>	<p>ORDER PART NUMBER</p> <p>LT1028AMH LT1028MH LT1028ACH LT1028CH</p>	 <p>S8 PACKAGE 8-LEAD PLASTIC SOIC $T_{JMAX} = 135^{\circ}\text{C}$, $\theta_{JA} = 140^{\circ}\text{C/W}$</p>	<p>ORDER PART NUMBER</p> <p>LT1028CS8 LT1128CS8</p> <p>S8 PART MARKING</p> <p>1028 1128</p>
 <p>N8 PACKAGE 8-LEAD PLASTIC DIP $T_{JMAX} = 130^{\circ}\text{C}$, $\theta_{JA} = 130^{\circ}\text{C/W}$</p> <p>J8 PACKAGE 8-LEAD CERAMIC DIP $T_{JMAX} = 165^{\circ}\text{C}$, $\theta_{JA} = 100^{\circ}\text{C/W}$</p> <p>OBSOLETE PACKAGE Consider N8 Package for Alternate Source</p>	<p>ORDER PART NUMBER</p> <p>LT1028ACN8 LT1028CN8 LT1128ACN8 LT1128CN8</p> <p>LT1028AMJ8 LT1028MJ8 LT1028ACJ8 LT1028CJ8 LT1128AMJ8 LT1128MJ8 LT1128CJ8</p>	 <p>SW PACKAGE 16-LEAD PLASTIC SOL $T_{JMAX} = 140^{\circ}\text{C}$, $\theta_{JA} = 130^{\circ}\text{C/W}$</p> <p>NOTE: THIS DEVICE IS NOT RECOMMENDED FOR NEW DESIGNS</p>	<p>ORDER PART NUMBER</p> <p>LT1028CSW</p>

Consult LTC Marketing for parts specified with wider operating temperature ranges.

ELECTRICAL CHARACTERISTICS $V_S = \pm 15V$, $T_A = 25^\circ C$, unless otherwise noted.

SYMBOL	PARAMETER	CONDITIONS	LT1028AM/AC LT1128AM/AC			LT1028M/C LT1128M/C			UNITS
			MIN	TYP	MAX	MIN	TYP	MAX	
V_{OS}	Input Offset Voltage	(Note 2)		10	40		20	80	μV
$\frac{\Delta V_{OS}}{\Delta Time}$	Long Term Input Offset Voltage Stability	(Note 3)		0.3			0.3		$\mu V/Mo$
I_{OS}	Input Offset Current	$V_{CM} = 0V$		12	50		18	100	nA
I_B	Input Bias Current	$V_{CM} = 0V$		± 25	± 90		± 30	± 180	nA
e_n	Input Noise Voltage	0.1Hz to 10Hz (Note 4)		35	75		35	90	nV _{p-p}
	Input Noise Voltage Density	$f_0 = 10Hz$ (Note 5) $f_0 = 1000Hz$, 100% tested		1.00 0.85	1.7 1.1		1.0 0.9	1.9 1.2	nV/ \sqrt{Hz} nV/ \sqrt{Hz}
I_n	Input Noise Current Density	$f_0 = 10Hz$ (Note 4 and 6) $f_0 = 1000Hz$, 100% tested		4.7 1.0	10.0 1.6		4.7 1.0	12.0 1.8	pA/ \sqrt{Hz} pA/ \sqrt{Hz}
	Input Resistance Common Mode Differential Mode			300 20			300 20		M Ω k Ω
	Input Capacitance			5			5		pF
	Input Voltage Range			± 11.0	± 12.2		± 11.0	± 12.2	V
CMRR	Common Mode Rejection Ratio	$V_{CM} = \pm 11V$		114	126		110	126	dB
PSRR	Power Supply Rejection Ratio	$V_S = \pm 4V$ to $\pm 18V$		117	133		110	132	dB
A_{VOL}	Large-Signal Voltage Gain	$R_L \geq 2k$, $V_O = \pm 12V$ $R_L \geq 1k$, $V_O = \pm 10V$ $R_L \geq 600\Omega$, $V_O = \pm 10V$		7.0 5.0 3.0	30.0 20.0 15.0		5.0 3.5 2.0	30.0 20.0 15.0	V/ μV V/ μV V/ μV
V_{OUT}	Maximum Output Voltage Swing	$R_L \geq 2k$ $R_L \geq 600\Omega$		± 12.3 ± 11.0	± 13.0 ± 12.2		± 12.0 ± 10.5	± 13.0 ± 12.2	V V
SR	Slew Rate	$A_{VCL} = -1$ LT1028 $A_{VCL} = -1$ LT1128		11.0 5.0	15.0 6.0		11.0 4.5	15.0 6.0	V/ μs V/ μs
GBW	Gain-Bandwidth Product	$f_0 = 20kHz$ (Note 7) LT1028 $f_0 = 200kHz$ (Note 7) LT1128		50 13	75 20		50 11	75 20	MHz MHz
Z_O	Open-Loop Output Impedance	$V_O = 0$, $I_O = 0$		80			80		Ω
I_S	Supply Current			7.4	9.5		7.6	10.5	mA

ELECTRICAL CHARACTERISTICS The ● denotes the specifications which apply over the temperature range $-55^\circ C \leq T_A \leq 125^\circ C$. $V_S = \pm 15V$, unless otherwise noted.

SYMBOL	PARAMETER	CONDITIONS		LT1028AM LT1128AM			LT1028M LT1128M			UNITS
				MIN	TYP	MAX	MIN	TYP	MAX	
V_{OS}	Input Offset Voltage	(Note 2)	●		30	120		45	180	μV
$\frac{\Delta V_{OS}}{\Delta Temp}$	Average Input Offset Drift	(Note 8)	●		0.2	0.8		0.25	1.0	$\mu V/^\circ C$
I_{OS}	Input Offset Current	$V_{CM} = 0V$	●		25	90		30	180	nA
I_B	Input Bias Current	$V_{CM} = 0V$	●		± 40	± 150		± 50	± 300	nA
	Input Voltage Range		●		± 10.3	± 11.7		± 10.3	± 11.7	V
CMRR	Common Mode Rejection Ratio	$V_{CM} = \pm 10.3V$	●		106	122		100	120	dB
PSRR	Power Supply Rejection Ratio	$V_S = \pm 4.5V$ to $\pm 16V$	●		110	130		104	130	dB
A_{VOL}	Large-Signal Voltage Gain	$R_L \geq 2k$, $V_O = \pm 10V$ $R_L \geq 1k$, $V_O = \pm 10V$	●		3.0 2.0	14.0 10.0		2.0 1.5	14.0 10.0	V/ μV V/ μV
V_{OUT}	Maximum Output Voltage Swing	$R_L \geq 2k$	●		± 10.3	± 11.6		± 10.3	± 11.6	V
I_S	Supply Current		●		8.7	11.5		9.0	13.0	mA

ELECTRICAL CHARACTERISTICS

The ● denotes the specifications which apply over the temperature range $0^{\circ}\text{C} \leq T_A \leq 70^{\circ}\text{C}$. $V_S = \pm 15\text{V}$, unless otherwise noted.

SYMBOL	PARAMETER	CONDITIONS		LT1028AC LT1128AC			LT1028C LT1128C			UNITS
				MIN	TYP	MAX	MIN	TYP	MAX	
V_{OS}	Input Offset Voltage	(Note 2)	●	15	80		30	125	μV	
$\frac{\Delta V_{OS}}{\Delta \text{Temp}}$	Average Input Offset Drift	(Note 8)	●	0.1	0.8		0.2	1.0	$\mu\text{V}/^{\circ}\text{C}$	
I_{OS}	Input Offset Current	$V_{CM} = 0\text{V}$	●	15	65		22	130	nA	
I_B	Input Bias Current	$V_{CM} = 0\text{V}$	●	± 30	± 120		± 40	± 240	nA	
	Input Voltage Range		●	± 10.5	± 12.0		± 10.5	± 12.0	V	
CMRR	Common Mode Rejection Ratio	$V_{CM} = \pm 10.5\text{V}$	●	110	124		106	124	dB	
PSRR	Power Supply Rejection Ratio	$V_S = \pm 4.5\text{V}$ to $\pm 18\text{V}$	●	114	132		107	132	dB	
A_{VOL}	Large-Signal Voltage Gain	$R_L \geq 2\text{k}$, $V_O = \pm 10\text{V}$	●	5.0	25.0		3.0	25.0	$\text{V}/\mu\text{V}$	
		$R_L \geq 1\text{k}$, $V_O = \pm 10\text{V}$		4.0	18.0		2.5	18.0	$\text{V}/\mu\text{V}$	
V_{OUT}	Maximum Output Voltage Swing	$R_L \geq 2\text{k}$	●	± 11.5	± 12.7		± 11.5	± 12.7	V	
		$R_L \geq 600\Omega$ (Note 10)		± 9.5	± 11.0		± 9.0	± 10.5	V	
I_S	Supply Current		●	8.0	10.5		8.2	11.5	mA	

ELECTRICAL CHARACTERISTICS

The ● denotes the specifications which apply over the temperature range $-40^{\circ}\text{C} \leq T_A \leq 85^{\circ}\text{C}$. $V_S = \pm 15\text{V}$, unless otherwise noted. (Note 11)

SYMBOL	PARAMETER	CONDITIONS		LT1028AC LT1128AC			LT1028C LT1128C			UNITS
				MIN	TYP	MAX	MIN	TYP	MAX	
V_{OS}	Input Offset Voltage		●	20	95		35	150	μV	
$\frac{\Delta V_{OS}}{\Delta \text{Temp}}$	Average Input Offset Drift	(Note 8)	●	0.2	0.8		0.25	1.0	$\mu\text{V}/^{\circ}\text{C}$	
I_{OS}	Input Offset Current	$V_{CM} = 0\text{V}$	●	20	80		28	160	nA	
I_B	Input Bias Current	$V_{CM} = 0\text{V}$	●	± 35	± 140		± 45	± 280	nA	
	Input Voltage Range		●	± 10.4	± 11.8		± 10.4	± 11.8	V	
CMRR	Common Mode Rejection Ratio	$V_{CM} = \pm 10.5\text{V}$	●	108	123		102	123	dB	
PSRR	Power Supply Rejection Ratio	$V_S = \pm 4.5\text{V}$ to $\pm 18\text{V}$	●	112	131		106	131	dB	
A_{VOL}	Large-Signal Voltage Gain	$R_L \geq 2\text{k}$, $V_O = \pm 10\text{V}$	●	4.0	20.0		2.5	20.0	$\text{V}/\mu\text{V}$	
		$R_L \geq 1\text{k}$, $V_O = \pm 10\text{V}$		3.0	14.0		2.0	14.0	$\text{V}/\mu\text{V}$	
V_{OUT}	Maximum Output Voltage Swing	$R_L \geq 2\text{k}$	●	± 11.0	± 12.5		± 11.0	± 12.5	V	
I_S	Supply Current		●	8.5	11.0		8.7	12.5	mA	

Note 1: Absolute Maximum Ratings are those values beyond which the life of a device may be impaired.

Note 2: Input Offset Voltage measurements are performed by automatic test equipment approximately 0.5 sec. after application of power. In addition, at $T_A = 25^{\circ}\text{C}$, offset voltage is measured with the chip heated to approximately 55°C to account for the chip temperature rise when the device is fully warmed up.

Note 3: Long Term Input Offset Voltage Stability refers to the average trend line of Offset Voltage vs. Time over extended periods after the first 30 days of operation. Excluding the initial hour of operation, changes in V_{OS} during the first 30 days are typically $2.5\mu\text{V}$.

Note 4: This parameter is tested on a sample basis only.

Note 5: 10Hz noise voltage density is sample tested on every lot with the exception of the S8 and S16 packages. Devices 100% tested at 10Hz are available on request.

Note 6: Current noise is defined and measured with balanced source resistors. The resultant voltage noise (after subtracting the resistor noise

on an RMS basis) is divided by the sum of the two source resistors to obtain current noise. Maximum 10Hz current noise can be inferred from 100% testing at 1kHz.

Note 7: Gain-bandwidth product is not tested. It is guaranteed by design and by inference from the slew rate measurement.

Note 8: This parameter is not 100% tested.

Note 9: The inputs are protected by back-to-back diodes. Current-limiting resistors are not used in order to achieve low noise. If differential input voltage exceeds $\pm 1.8\text{V}$, the input current should be limited to 25mA.

Note 10: This parameter guaranteed by design, fully warmed up at $T_A = 70^{\circ}\text{C}$. It includes chip temperature increase due to supply and load currents.

Note 11: The LT1028/LT1128 are designed, characterized and expected to meet these extended temperature limits, but are not tested at -40°C and 85°C . Guaranteed I grade parts are available. Consult factory.

TYPICAL PERFORMANCE CHARACTERISTICS

10Hz Voltage Noise Distribution

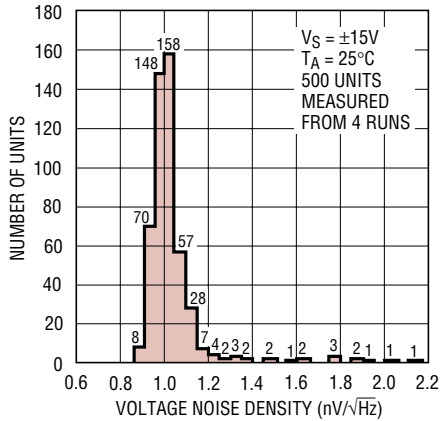

LT1028/1128 • TPC01

Wideband Noise, DC to 20kHz

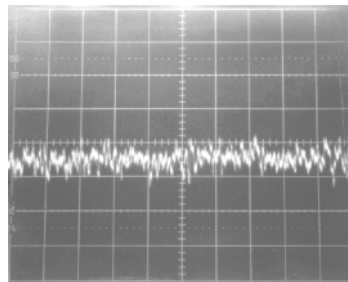

VERTICAL SCALE = 0.5µV/DIV
 HORIZONTAL SCALE = 0.5ms/DIV

Wideband Voltage Noise (0.1Hz to Frequency Indicated)

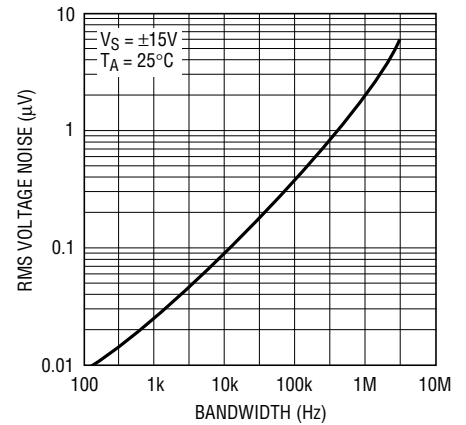

LT1028/1128 • TPC03

Total Noise vs Matched Source Resistance

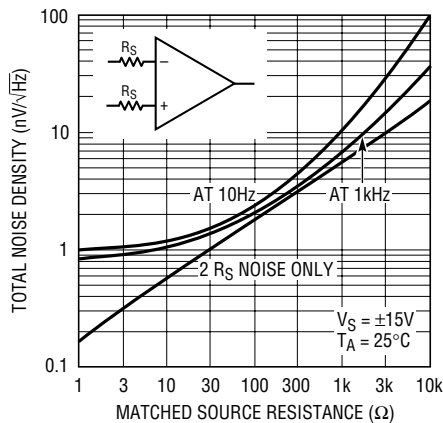

LT1028/1128 • TPC04

Total Noise vs Unmatched Source Resistance

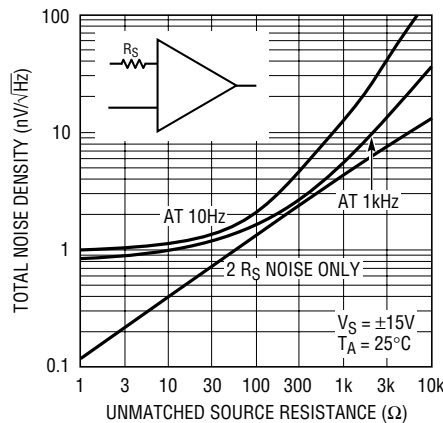

LT1028/1128 • TPC05

Current Noise Spectrum

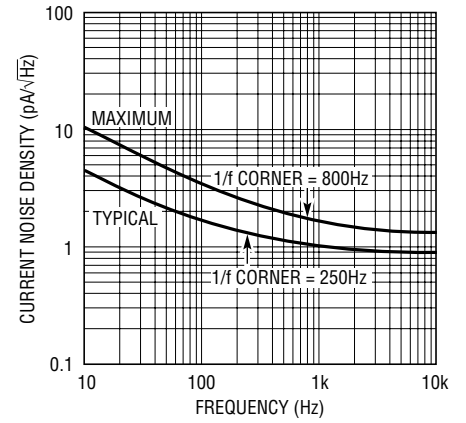

LT1028/1128 • TPC06

0.1Hz to 10Hz Voltage Noise

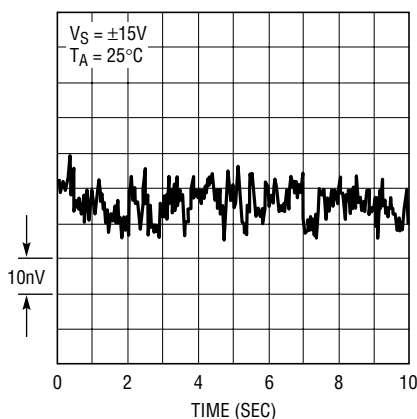

LT1028/1128 • TPC07

0.01Hz to 1Hz Voltage Noise

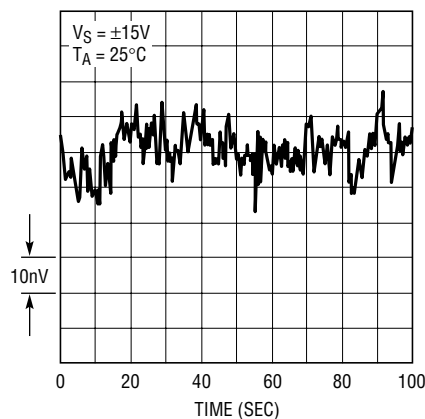

LT1028/1128 • TPC08

Voltage Noise vs Temperature

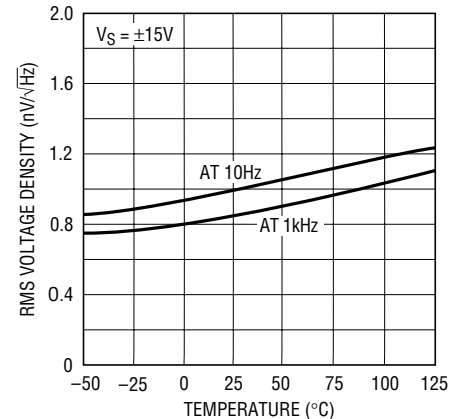

LT1028/1128 • TPC09

TYPICAL PERFORMANCE CHARACTERISTICS

Distribution of Input Offset Voltage

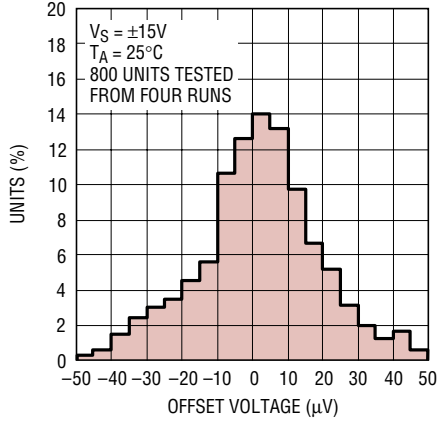

Offset Voltage Drift with Temperature of Representative Units

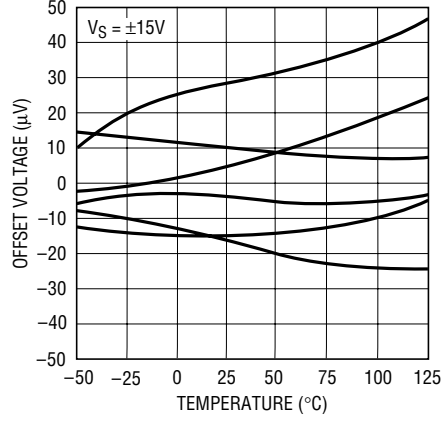

Long-Term Stability of Five Representative Units

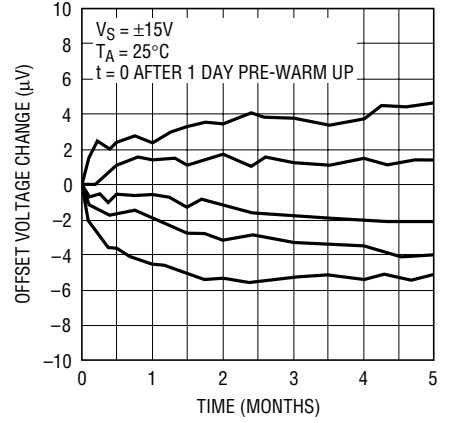

Warm-Up Drift

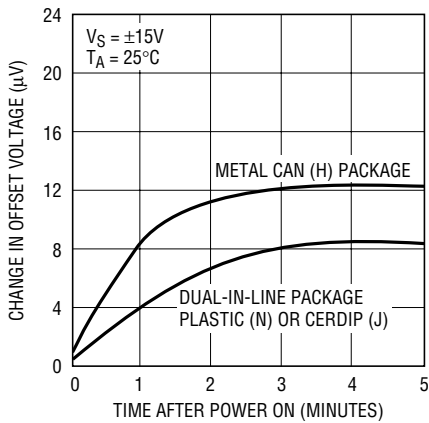

Input Bias and Offset Currents Over Temperature

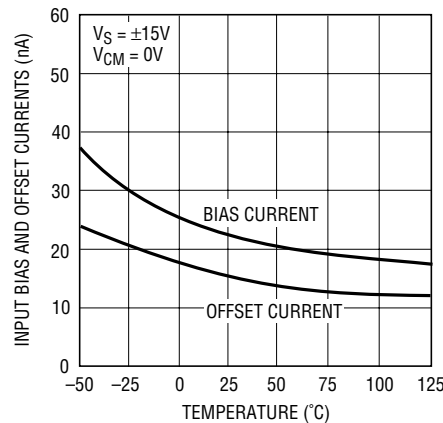

Bias Current Over the Common Mode Range

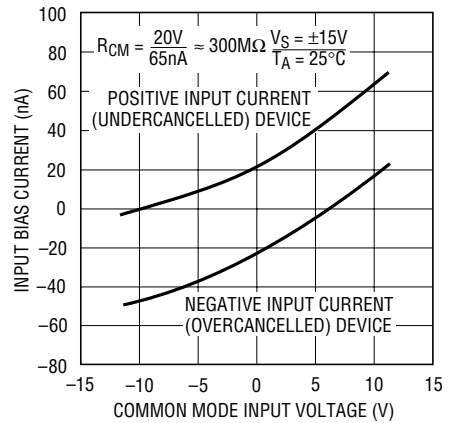

Voltage Noise vs Supply Voltage

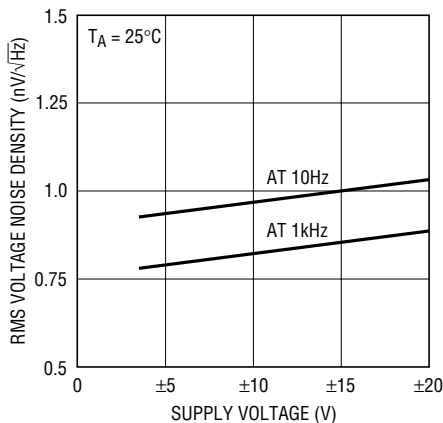

Supply Current vs Temperature

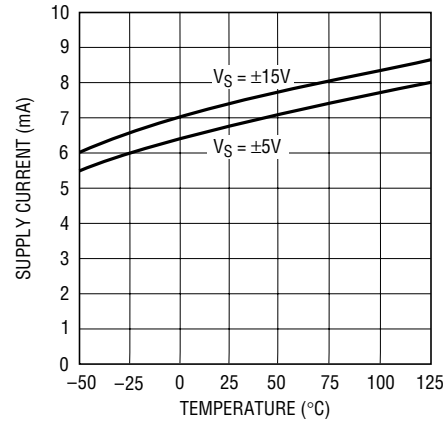

Output Short-Circuit Current vs Time

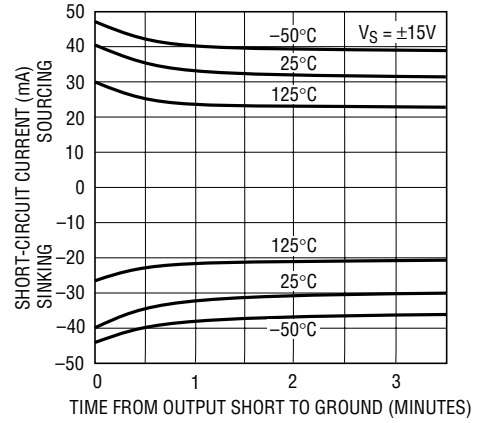

TYPICAL PERFORMANCE CHARACTERISTICS

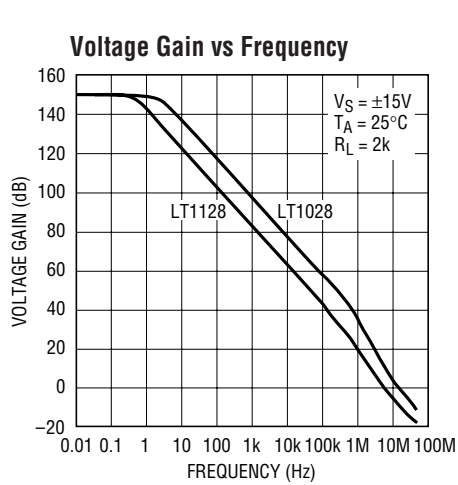

LT1028/1128 • TPC19

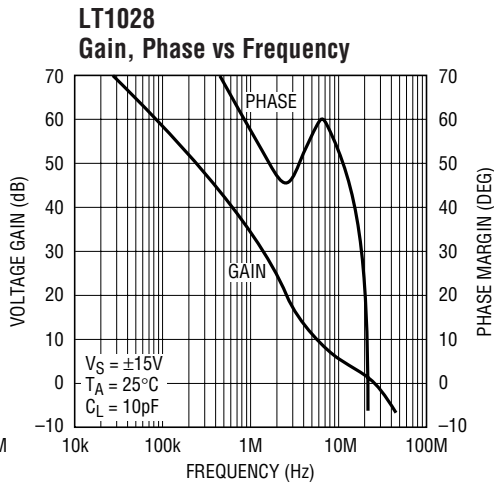

LT1028/1128 • TPC20

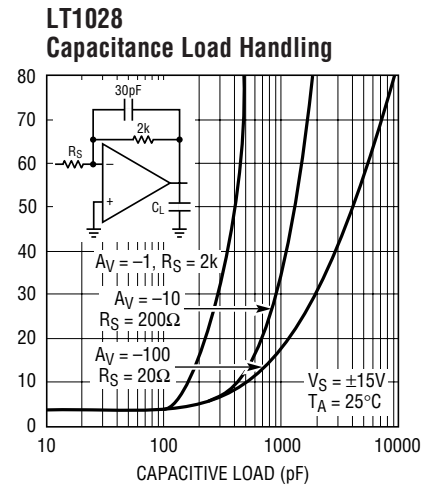

LT1028/1128 • TPC21

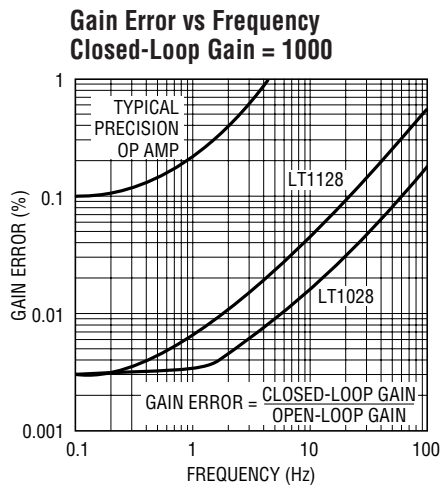

LT1028/1128 • TPC22

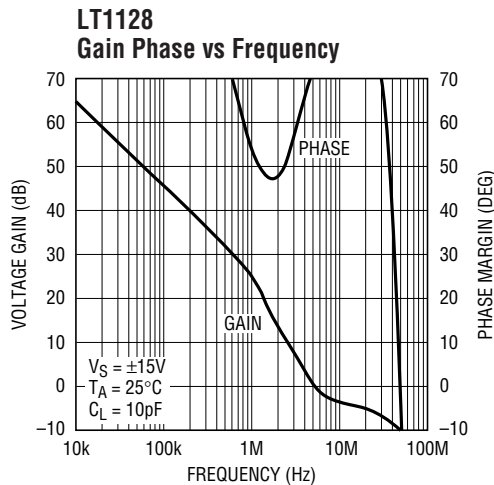

LT1028/1128 • TPC23

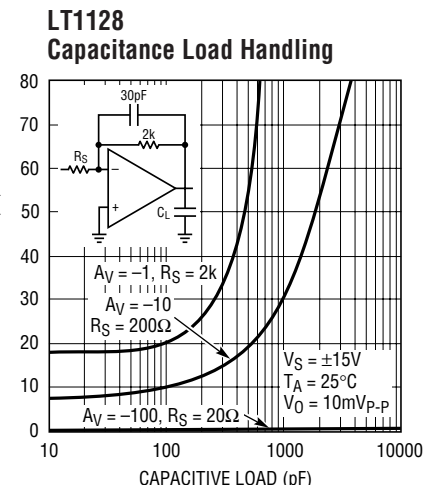

LT1028/1128 • TPC24

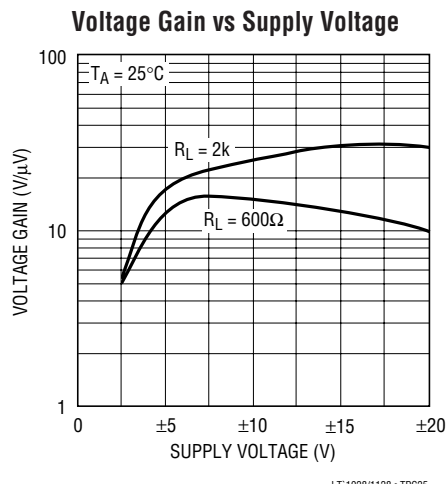

LT1028/1128 • TPC25

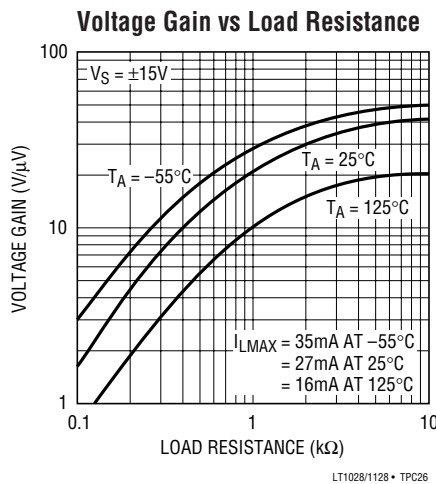

LT1028/1128 • TPC26

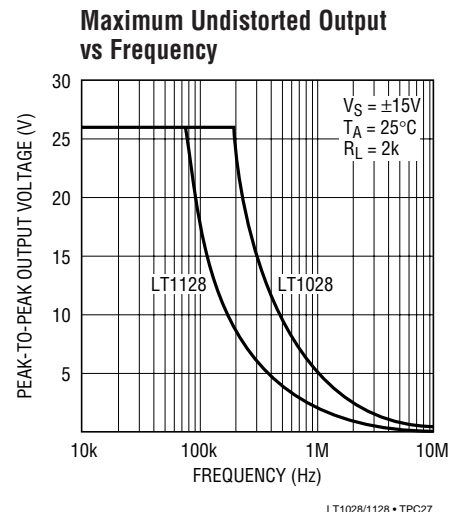

LT1028/1128 • TPC27

TYPICAL PERFORMANCE CHARACTERISTICS

LT1028
Large-Signal Transient Response

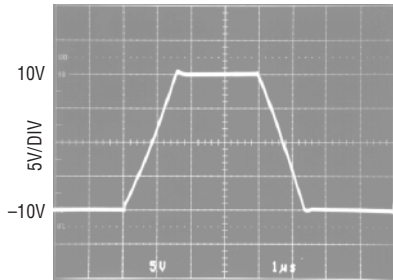

1μs/DIV
 $A_V = -1$, $R_S = R_F = 2k$, $C_F = 15pF$

LT1028
Small-Signal Transient Response

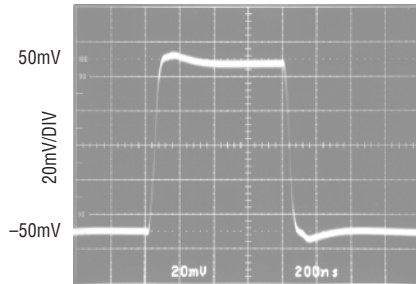

0.2μs/DIV
 $A_V = -1$, $R_S = R_F = 2k$
 $C_F = 15pF$, $C_L = 80pF$

LT1028
Slew Rate, Gain-Bandwidth Product Over Temperature

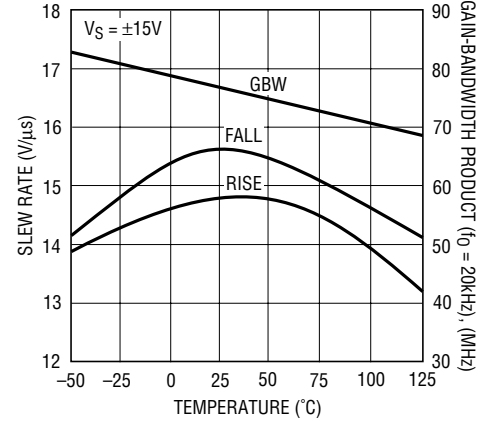

LT1028/1128 • TPC30

LT1128
Large-Signal Transient Response

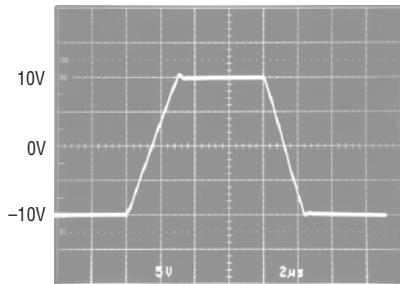

2μs/DIV
 $A_V = -1$, $R_S = R_F = 2k$, $C_F = 30pF$

LT1128
Small-Signal Transient Response

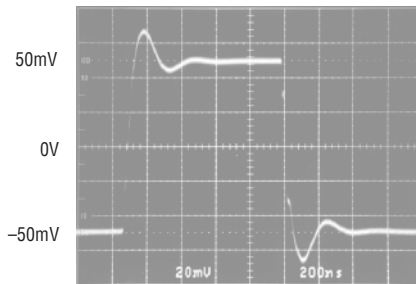

0.2μs/DIV
 $A_V = 1$, $C_L = 10pF$

LT1128
Slew Rate, Gain-Bandwidth Product Over Temperature

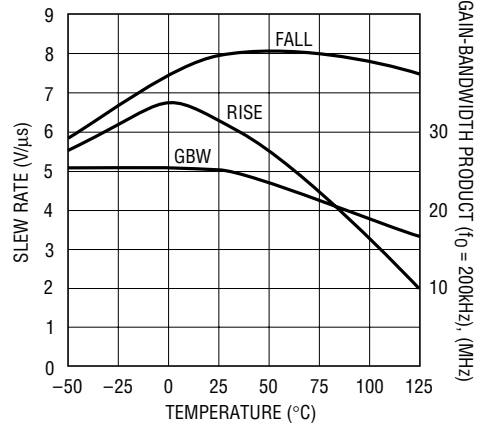

LT1028/1128 • TPC33

Closed-Loop Output Impedance

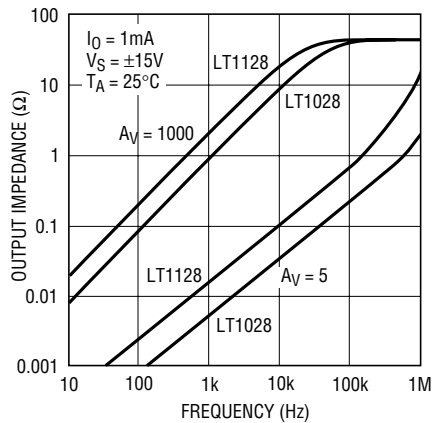

LT1028/1128 • TPC34

LT1128
Slew Rate, Gain-Bandwidth Product vs Over-Compensation Capacitor

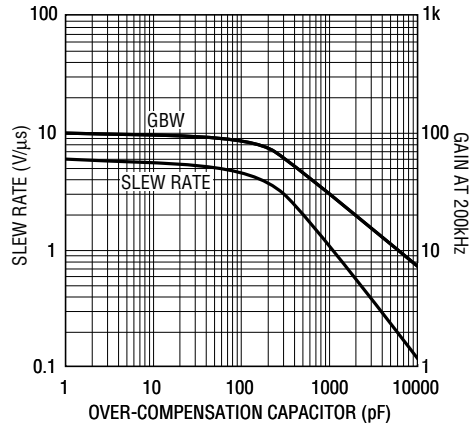

LT1028/1128 • TPC35

LT1028
Slew Rate, Gain-Bandwidth Product vs Over-Compensation Capacitor

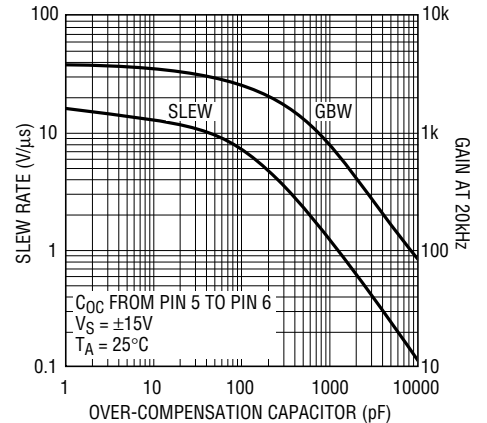

LT1028/1128 • TPC36

TYPICAL PERFORMANCE CHARACTERISTICS

Common Mode Limit Over Temperature

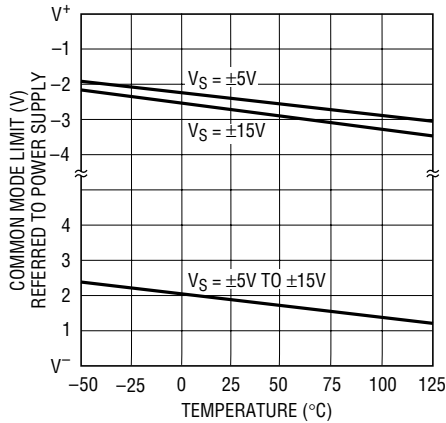

LT1028/1128 • TPC37

Common Mode Rejection Ratio vs Frequency

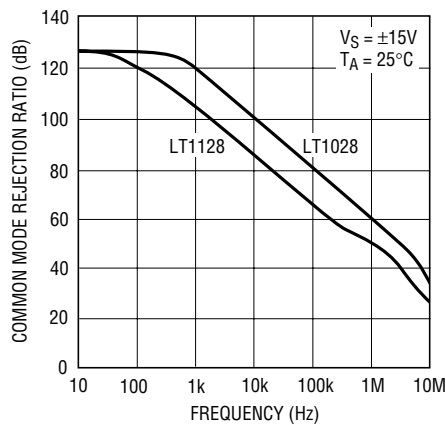

LT1028/1128 • TPC38

Power Supply Rejection Ratio vs Frequency

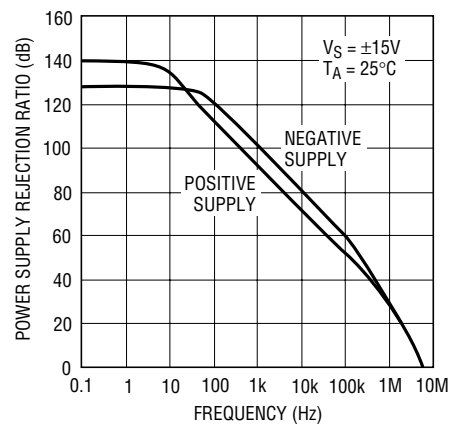

LT1028/1128 • TPC39

LT1028 Total Harmonic Distortion vs Frequency and Load Resistance

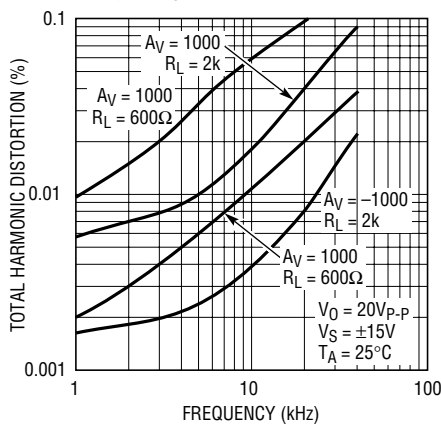

LT1028/1128 • TPC40

LT1028 Total Harmonic Distortion vs Closed-Loop Gain

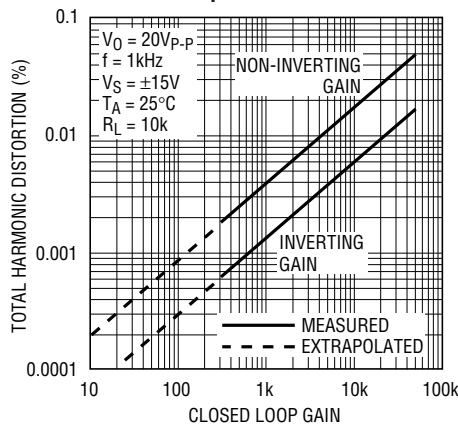

LT1028/1128 • TPC41

High Frequency Voltage Noise vs Frequency

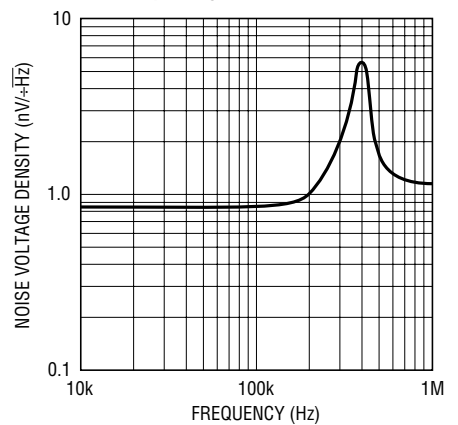

LT1028/1128 • TPC42

LT1128 Total Harmonic Distortion vs Frequency and Load Resistance

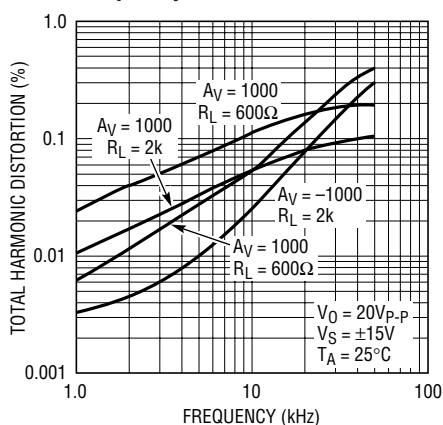

LT1028/1128 • TPC43

LT1128 Total Harmonic Distortion vs Closed-Loop Gain

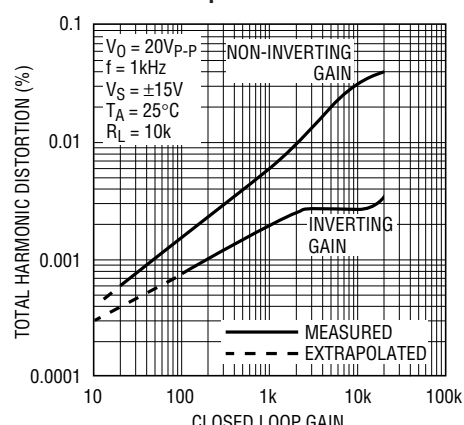

LT1028/1128 • TPC44

APPLICATIONS INFORMATION—NOISE

Voltage Noise vs Current Noise

The LT1028/LT1128's less than $1\text{nV}/\sqrt{\text{Hz}}$ voltage noise is three times better than the lowest voltage noise heretofore available (on the LT1007/1037). A necessary condition for such low voltage noise is operating the input transistors at nearly 1mA of collector currents, because voltage noise is inversely proportional to the square root of the collector current. Current noise, however, is directly proportional to the square root of the collector current. Consequently, the LT1028/LT1128's current noise is significantly higher than on most monolithic op amps.

Therefore, to realize truly low noise performance it is important to understand the interaction between voltage noise (e_n), current noise (I_n) and resistor noise (r_n).

Total Noise vs Source Resistance

The total input referred noise of an op amp is given by

$$e_t = [e_n^2 + r_n^2 + (I_n R_{eq})^2]^{1/2}$$

where R_{eq} is the total equivalent source resistance at the two inputs, and

$$r_n = \sqrt{4kTR_{eq}} = 0.13\sqrt{R_{eq}} \text{ in nV}/\sqrt{\text{Hz}} \text{ at } 25^\circ\text{C}$$

As a numerical example, consider the total noise at 1kHz of the gain 1000 amplifier shown below.

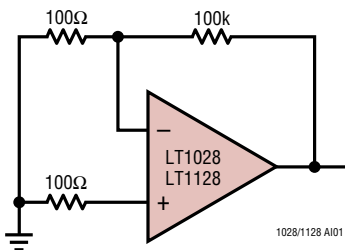

$$R_{eq} = 100\Omega + 100\Omega \parallel 100k \approx 200\Omega$$

$$r_n = 0.13\sqrt{200} = 1.84\text{nV}/\sqrt{\text{Hz}}$$

$$e_n = 0.85\text{nV}/\sqrt{\text{Hz}}$$

$$I_n = 1.0\text{pA}/\sqrt{\text{Hz}}$$

$$e_t = [0.85^2 + 1.84^2 + (1.0 \times 0.2)^2]^{1/2} = 2.04\text{nV}/\sqrt{\text{Hz}}$$

$$\text{Output noise} = 1000 e_t = 2.04\mu\text{V}/\sqrt{\text{Hz}}$$

At very low source resistance ($R_{eq} < 40\Omega$) voltage noise dominates. As R_{eq} is increased resistor noise becomes the

largest term, as in the example above, and the LT1028/LT1128's voltage noise becomes negligible. As R_{eq} is further increased, current noise becomes important. At 1kHz, when R_{eq} is in excess of 20k, the current noise component is larger than the resistor noise. The total noise versus matched source resistance plot illustrates the above calculations.

The plot also shows that current noise is more dominant at low frequencies, such as 10Hz. This is because resistor noise is flat with frequency, while the 1/f corner of current noise is typically at 250Hz. At 10Hz when $R_{eq} > 1k$, the current noise term will exceed the resistor noise.

When the source resistance is unmatched, the total noise versus unmatched source resistance plot should be consulted. Note that total noise is lower at source resistances below 1k because the resistor noise contribution is less. When $R_S > 1k$ total noise is not improved, however. This is because bias current cancellation is used to reduce input bias current. The cancellation circuitry injects two correlated current noise components into the two inputs. With matched source resistors the injected current noise creates a common-mode voltage noise and gets rejected by the amplifier. With source resistance in one input only, the cancellation noise is added to the amplifier's inherent noise.

In summary, the LT1028/LT1128 are the optimum amplifiers for noise performance, provided that the source resistance is kept low. The following table depicts which op amp manufactured by Linear Technology should be used to minimize noise, as the source resistance is increased beyond the LT1028/LT1128's level of usefulness.

Best Op Amp for Lowest Total Noise vs Source Resistance

SOURCE RESIS- TANCE(Ω) (Note 1)	BEST OP AMP	
	AT LOW FREQ(10Hz)	WIDEBAND(1kHz)
0 to 400	LT1028/LT1128	LT1028/LT1128
400 to 4k	LT1007/1037	LT1028/LT1128
4k to 40k	LT1001	LT1007/1037
40k to 500k	LT1012	LT1001
500k to 5M	LT1012 or LT1055	LT1012
>5M	LT1055	LT1055

Note 1: Source resistance is defined as matched or unmatched, e.g., $R_S = 1k$ means: 1k at each input, or 1k at one input and zero at the other.

APPLICATIONS INFORMATION—NOISE

Noise Testing – Voltage Noise

The LT1028/LT1128's RMS voltage noise density can be accurately measured using the Quan Tech Noise Analyzer, Model 5173 or an equivalent noise tester. Care should be taken, however, to subtract the noise of the source resistor used. Prefabricated test cards for the Model 5173 set the device under test in a closed-loop gain of 31 with a 60Ω source resistor and a 1.8k feedback resistor. The noise of this resistor combination is $0.13\sqrt{58} = 1.0\text{nV}/\sqrt{\text{Hz}}$. An LT1028/LT1128 with $0.85\text{nV}/\sqrt{\text{Hz}}$ noise will read $(0.85^2 + 1.0^2)^{1/2} = 1.31\text{nV}/\sqrt{\text{Hz}}$. For better resolution, the resistors should be replaced with a 10Ω source and 300Ω feedback resistor. Even a 10Ω resistor will show an apparent noise which is 8% to 10% too high.

The 0.1Hz to 10Hz peak-to-peak noise of the LT1028/LT1128 is measured in the test circuit shown. The frequency response of this noise tester indicates that the 0.1Hz corner is defined by only one zero. The test time to measure 0.1Hz to 10Hz noise should not exceed 10 seconds, as this time limit acts as an additional zero to eliminate noise contributions from the frequency band below 0.1Hz.

Measuring the typical 35nV peak-to-peak noise performance of the LT1028/LT1128 requires special test precautions:

- The device should be warmed up for at least five minutes. As the op amp warms up, its offset voltage changes typically 10μV due to its chip temperature increasing 30°C to 40°C from the moment the power supplies are turned on. In the 10 second measurement interval these temperature-induced effects can easily exceed tens of nanovolts.
- For similar reasons, the device must be well shielded from air current to eliminate the possibility of thermoelectric effects in excess of a few nanovolts, which would invalidate the measurements.
- Sudden motion in the vicinity of the device can also "feedthrough" to increase the observed noise.

A noise-voltage density test is recommended when measuring noise on a large number of units. A 10Hz noise-voltage density measurement will correlate well with a 0.1Hz to 10Hz peak-to-peak noise reading since both results are determined by the white noise and the location of the 1/f corner frequency.

0.1Hz to 10Hz Noise Test Circuit

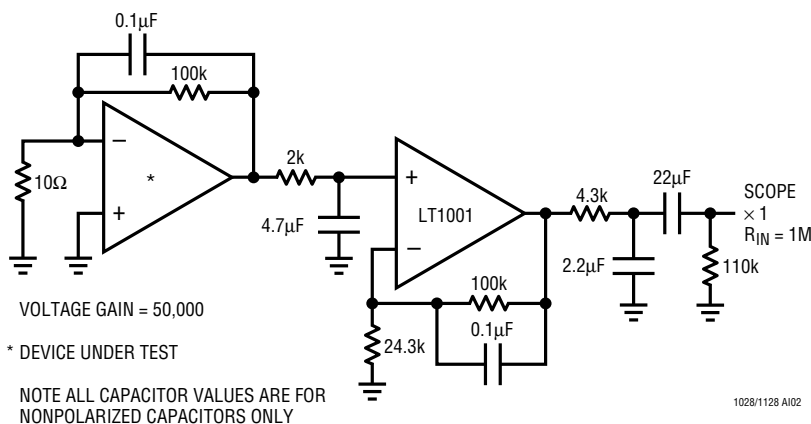

0.1Hz to 10Hz Peak-to-Peak Noise Tester Frequency Response

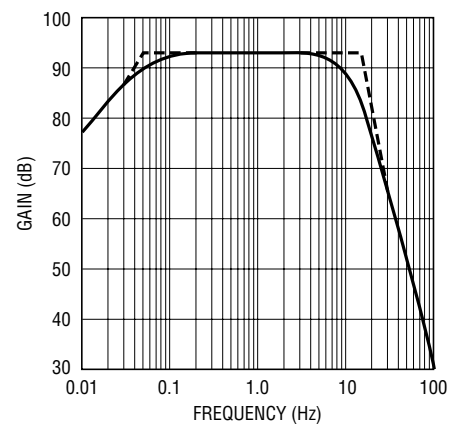

APPLICATIONS INFORMATION—NOISE

Noise Testing – Current Noise

Current noise density (I_n) is defined by the following formula, and can be measured in the circuit shown:

$$I_n = \frac{[e_{no}^2 - (31 \times 18.4nV/\sqrt{Hz})^2]^{1/2}}{20k \times 31}$$

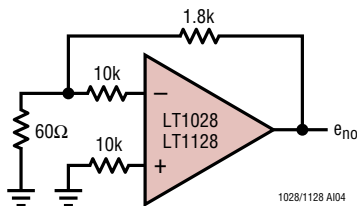

If the Quan Tech Model 5173 is used, the noise reading is input-referred, therefore the result should not be divided by 31; the resistor noise should not be multiplied by 31.

100% Noise Testing

The 1kHz voltage and current noise is 100% tested on the LT1028/LT1128 as part of automated testing; the approximate frequency response of the filters is shown. The limits on the automated testing are established by extensive correlation tests on units measured with the Quan Tech Model 5173.

10Hz voltage noise density is sample tested on every lot. Devices 100% tested at 10Hz are available on request for an additional charge.

10Hz current noise is not tested on every lot but it can be inferred from 100% testing at 1kHz. A look at the current noise spectrum plot will substantiate this statement. The only way 10Hz current noise can exceed the guaranteed limits is if its 1/f corner is higher than 800Hz and/or its white noise is high. If that is the case then the 1kHz test will fail.

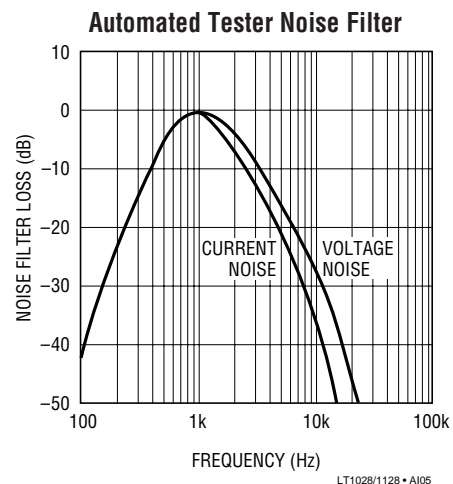

APPLICATIONS INFORMATION

General

The LT1028/LT1128 series devices may be inserted directly into OP-07, OP-27, OP-37, LT1007 and LT1037 sockets with or without removal of external nulling components. In addition, the LT1028/LT1128 may be fitted to 5534 sockets with the removal of external compensation components.

Offset Voltage Adjustment

The input offset voltage of the LT1028/LT1128 and its drift with temperature, are permanently trimmed at wafer testing to a low level. However, if further adjustment of V_{OS} is necessary, the use of a 1k nulling potentiometer will not degrade drift with temperature. Trimming to a value other

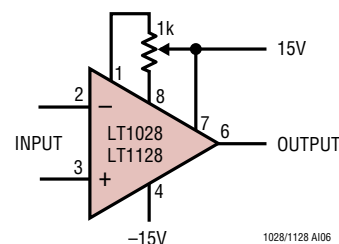

than zero creates a drift of $(V_{OS}/300)\mu V/^\circ C$, e.g., if V_{OS} is adjusted to $300\mu V$, the change in drift will be $1\mu V/^\circ C$.

The adjustment range with a 1k pot is approximately $\pm 1.1mV$.

Offset Voltage and Drift

Thermocouple effects, caused by temperature gradients across dissimilar metals at the contacts to the input

APPLICATIONS INFORMATION

terminals, can exceed the inherent drift of the amplifier unless proper care is exercised. Air currents should be minimized, package leads should be short, the two input leads should be close together and maintained at the same temperature.

The circuit shown to measure offset voltage is also used as the burn-in configuration for the LT1028/LT1128.

Test Circuit for Offset Voltage and Offset Voltage Drift with Temperature

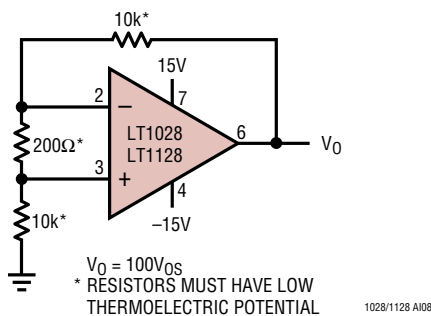

Unity-Gain Buffer Applications (LT1128 Only)

When $R_F \leq 100\Omega$ and the input is driven with a fast, large-signal pulse ($>1V$), the output waveform will look as shown in the pulsed operation diagram.

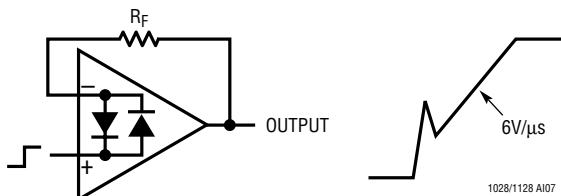

During the fast feedthrough-like portion of the output, the input protection diodes effectively short the output to the input and a current, limited only by the output short-circuit protection, will be drawn by the signal generator. With $R_F \geq 500\Omega$, the output is capable of handling the current requirements ($I_L \leq 20mA$ at 10V) and the amplifier stays in its active mode and a smooth transition will occur.

As with all operational amplifiers when $R_F > 2k$, a pole will be created with R_F and the amplifier's input capacitance, creating additional phase shift and reducing the phase margin. A small capacitor (20pF to 50pF) in parallel with R_F will eliminate this problem.

Frequency Response

The LT1028's Gain, Phase vs Frequency plot indicates that the device is stable in closed-loop gains greater than +2 or -1 because phase margin is about 50° at an open-loop gain of 6dB. In the voltage follower configuration phase margin seems inadequate. This is indeed true when the output is shorted to the inverting input and the noninverting input is driven from a 50Ω source impedance. However, when feedback is through a parallel R-C network (provided $C_F < 68pF$), the LT1028 will be stable because of interaction between the input resistance and capacitance and the feedback network. Larger source resistance at the noninverting input has a similar effect. The following voltage follower configurations are stable:

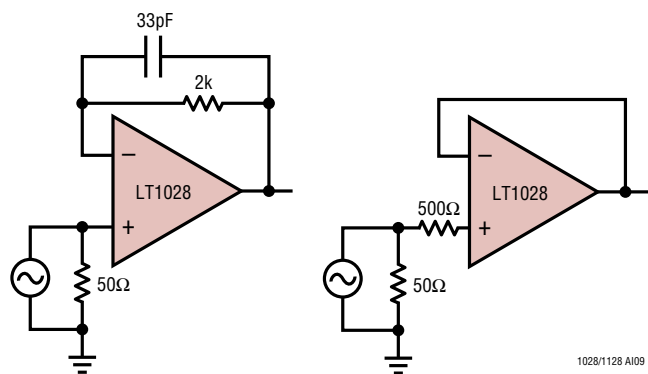

Another configuration which requires unity-gain stability is shown below. When C_F is large enough to effectively short the output to the input at 15MHz, oscillations can occur. The insertion of $R_{S2} \geq 500\Omega$ will prevent the LT1028 from oscillating. When $R_{S1} \geq 500\Omega$, the additional noise contribution due to the presence of R_{S2} will be minimal. When $R_{S1} \leq 100\Omega$, R_{S2} is not necessary, because R_{S1} represents a heavy load on the output through the C_F short. When $100\Omega < R_{S1} < 500\Omega$, R_{S2} should match R_{S1} . For example, $R_{S1} = R_{S2} = 300\Omega$ will be stable. The noise increase due to R_{S2} is 40%.

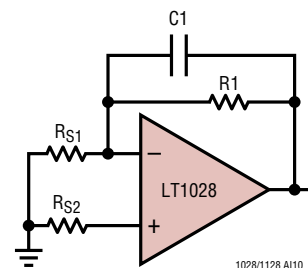

APPLICATIONS INFORMATION

If C_F is only used to cut noise bandwidth, a similar effect can be achieved using the over-compensation terminal.

The Gain, Phase plot also shows that phase margin is about 45° at gain of 10 (20dB). The following configura-

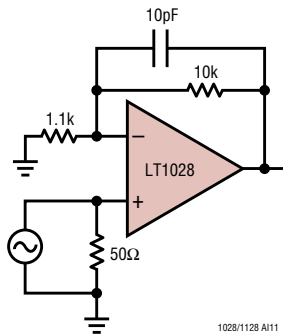

1028/1128 AI11

tion has a high ($\approx 70\%$) overshoot without the 10pF capacitor because of additional phase shift caused by the feedback resistor – input capacitance pole. The presence of the 10pF capacitor cancels this pole and reduces overshoot to 5%.

Over-Compensation

The LT1028/LT1128 are equipped with a frequency over-compensation terminal (Pin 5). A capacitor connected between Pin 5 and the output will reduce noise bandwidth. Details are shown on the Slew Rate, Gain-Bandwidth Product vs Over-Compensation Capacitor plot. An additional benefit is increased capacitive load handling capability.

TYPICAL APPLICATIONS

Strain Gauge Signal Conditioner with Bridge Excitation

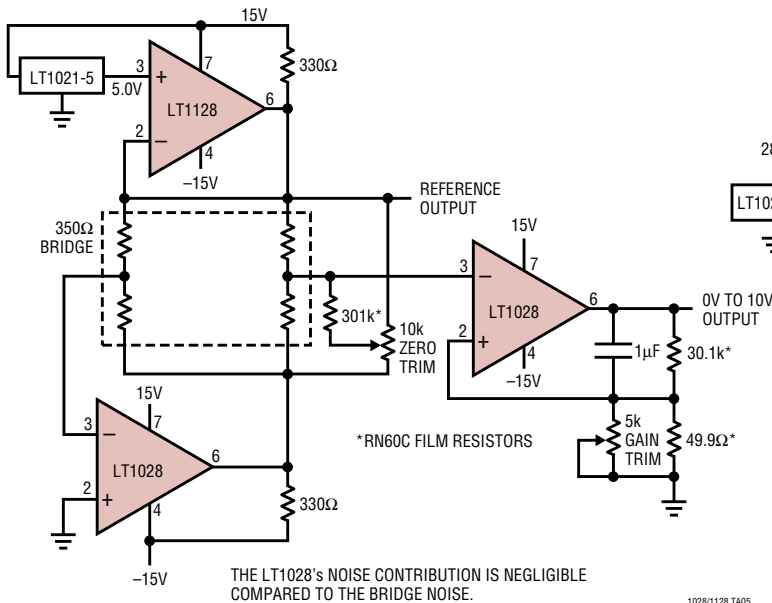

1028/1128 TA05

Low Noise Voltage Regulator

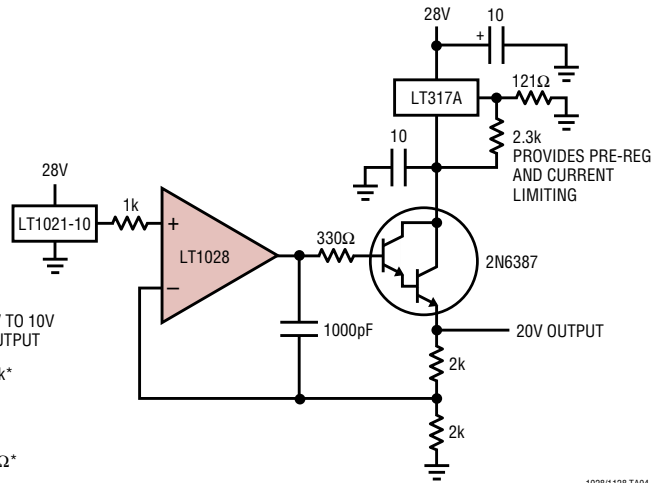

1028/1128 TA04

TYPICAL APPLICATIONS

Paralleling Amplifiers to Reduce Voltage Noise

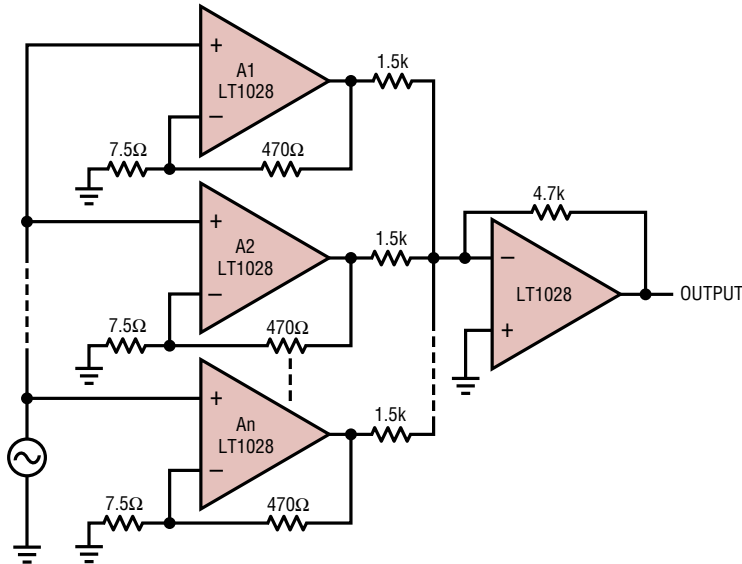

1. ASSUME VOLTAGE NOISE OF LT1028 AND 7.5Ω SOURCE RESISTOR = $0.9\text{nV}/\sqrt{\text{Hz}}$.
2. GAIN WITH n LT1028s IN PARALLEL = $n \times 200$.
3. OUTPUT NOISE = $\sqrt{n} \times 200 \times 0.9\text{nV}/\sqrt{\text{Hz}}$.
4. INPUT REFERRED NOISE = $\frac{\text{OUTPUT NOISE}}{n \times 200} = \frac{0.9}{\sqrt{n}}\text{nV}/\sqrt{\text{Hz}}$.
5. NOISE CURRENT AT INPUT INCREASES \sqrt{n} TIMES.
6. IF $n = 5$, GAIN = 1000, BANDWIDTH = 1MHz, RMS NOISE, DC TO 1MHz = $\frac{2\mu\text{V}}{\sqrt{5}} = 0.9\mu\text{V}$.

1028/1128 TA03

Phono Preamplifier

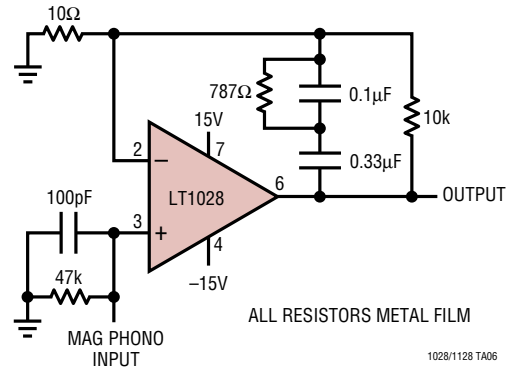

ALL RESISTORS METAL FILM

1028/1128 TA06

Tape Head Amplifier

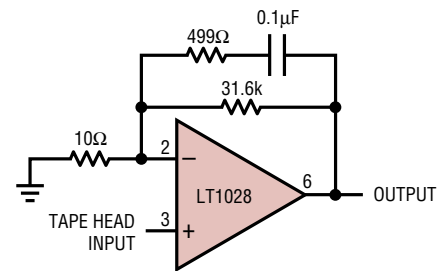

ALL RESISTORS METAL FILM

1028/1128 TA07

Low Noise, Wide Bandwidth Instrumentation Amplifier

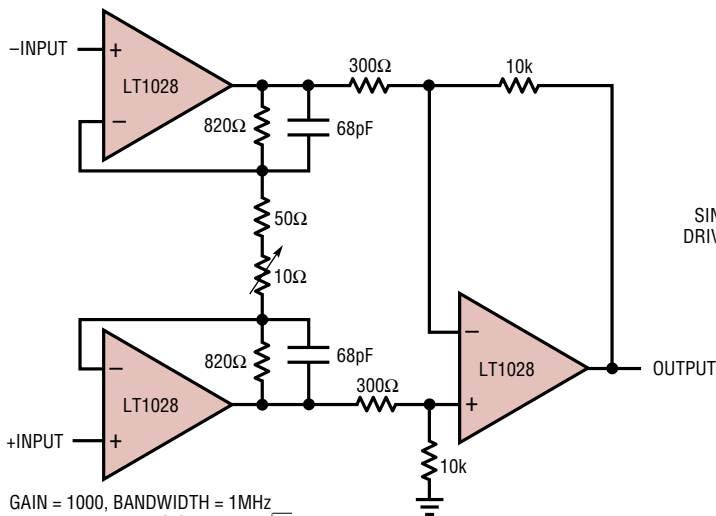

GAIN = 1000, BANDWIDTH = 1MHz
 INPUT REFERRED NOISE = $1.5\text{nV}/\sqrt{\text{Hz}}$ AT 1kHz
 WIDEBAND NOISE -DC TO 1MHz = $3\mu\text{VRMS}$
 IF BW LIMITED TO DC TO 100kHz = $0.55\mu\text{VRMS}$

1028/1128 TA08

Gyro Pick-Off Amplifier

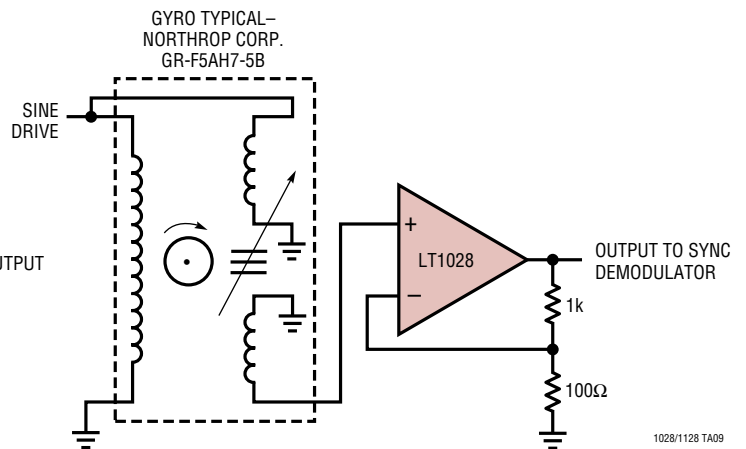

1028/1128 TA09

TYPICAL APPLICATIONS

Super Low Distortion Variable Sine Wave Oscillator

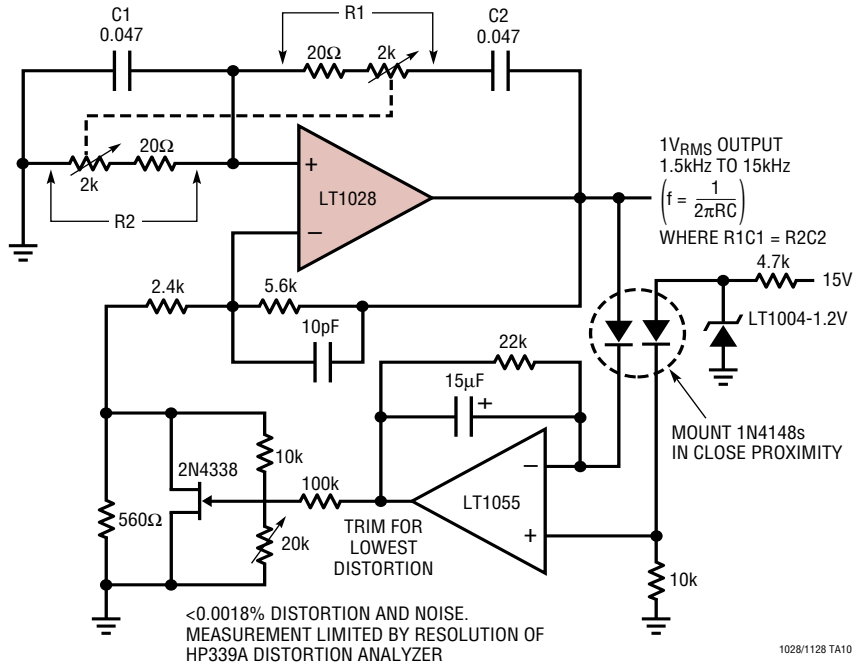

Chopper-Stabilized Amplifier

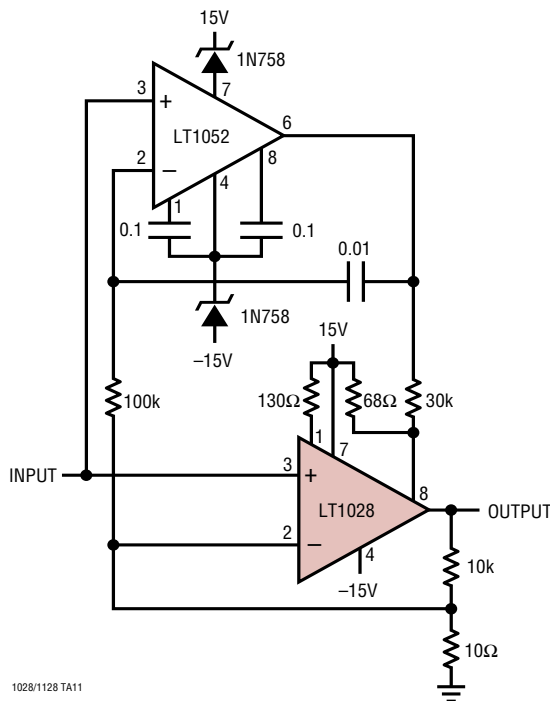

SCHEMATIC DIAGRAM

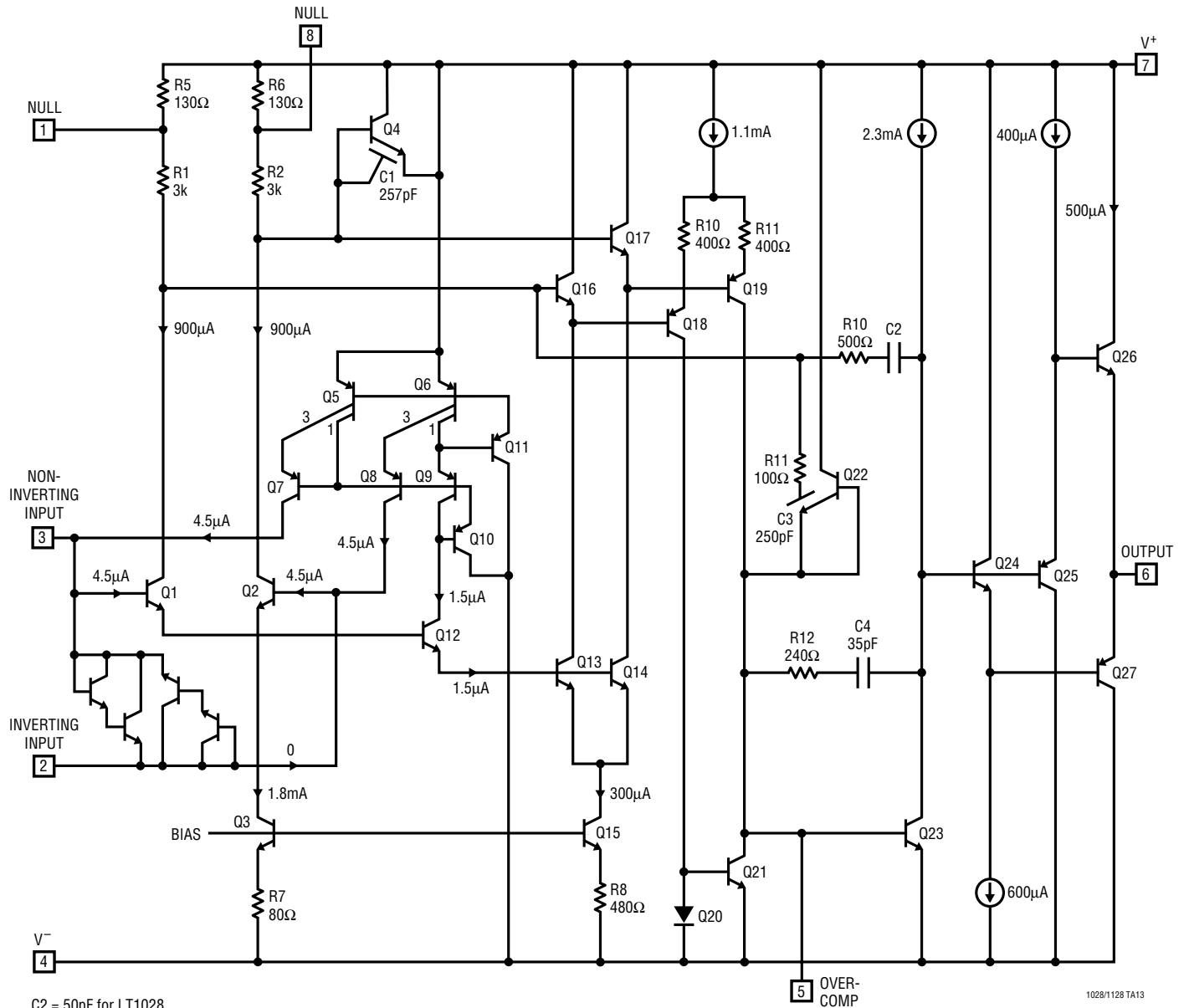

C2 = 50pF for LT1028
 C2 = 275pF for LT1128

1028/1128 TA13

PACKAGE DESCRIPTION

OBSOLETE PACKAGE

J8 Package
8-Lead CERDIP (Narrow .300 Inch, Hermetic)
 (Reference LTC DWG # 05-08-1110)

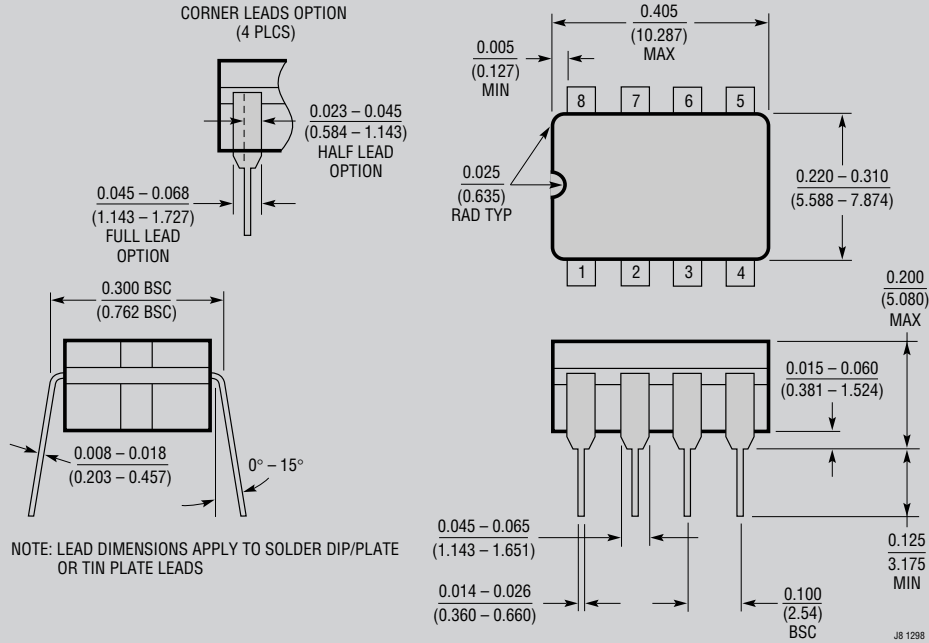

N8 Package
8-Lead PDIP (Narrow .300 Inch)
 (Reference LTC DWG # 05-08-1510)

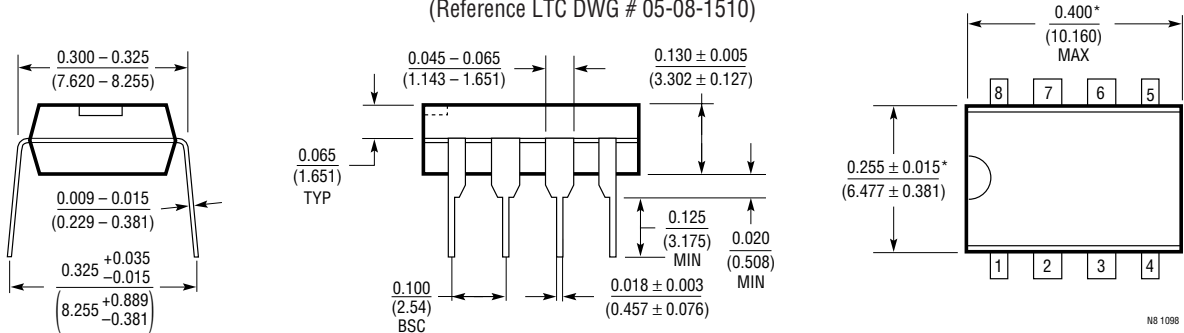

*THESE DIMENSIONS DO NOT INCLUDE MOLD FLASH OR PROTRUSIONS. MOLD FLASH OR PROTRUSIONS SHALL NOT EXCEED 0.010 INCH (0.254mm)

S8 Package
8-Lead Plastic Small Outline (Narrow .150 Inch)
 (Reference LTC DWG # 05-08-1610)

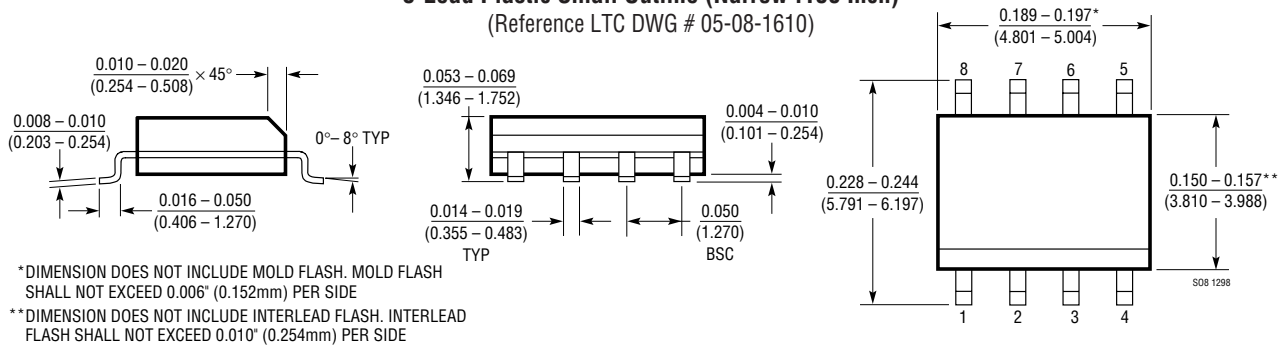

PACKAGE DESCRIPTION

S Package 16-Lead Plastic Small Outline (Narrow .150 Inch) (Reference LTC DWG # 05-08-1610)

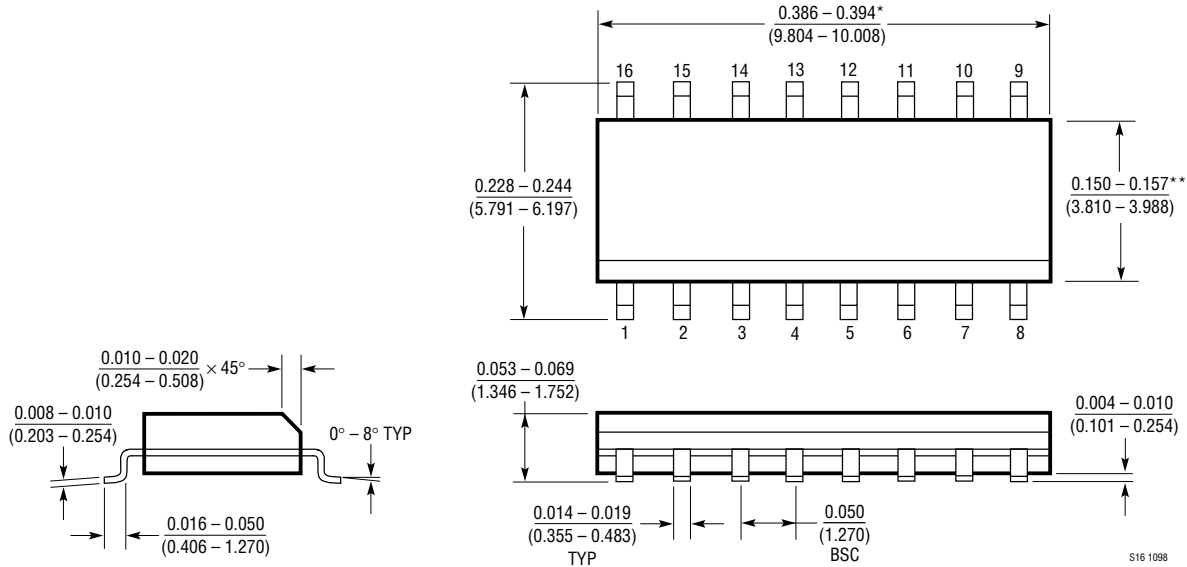

* DIMENSION DOES NOT INCLUDE MOLD FLASH. MOLD FLASH SHALL NOT EXCEED 0.006" (0.152mm) PER SIDE
 ** DIMENSION DOES NOT INCLUDE INTERLEAD FLASH. INTERLEAD FLASH SHALL NOT EXCEED 0.010" (0.254mm) PER SIDE

H Package 3-Lead TO-39 Metal Can (Reference LTC DWG # 05-08-1330)

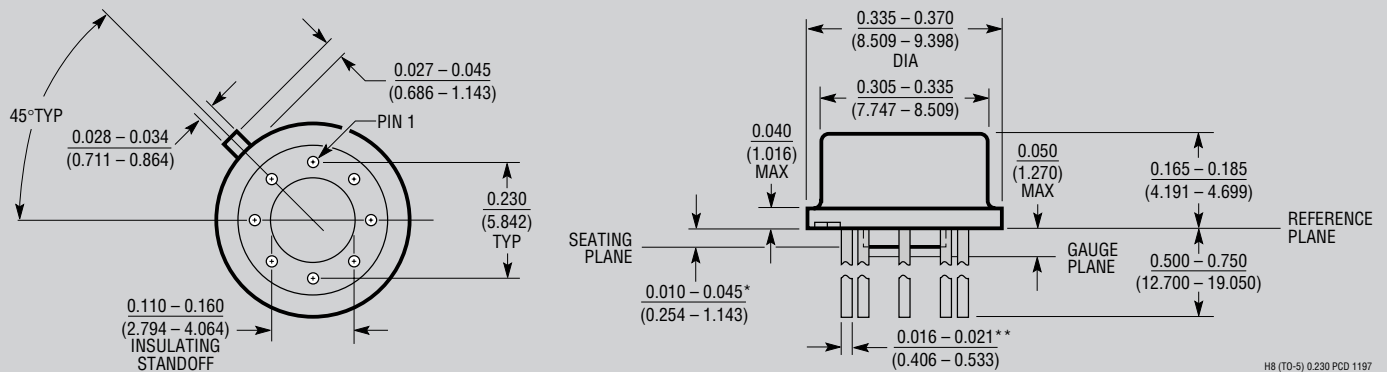

* LEAD DIAMETER IS UNCONTROLLED BETWEEN THE REFERENCE PLANE AND 0.045" BELOW THE REFERENCE PLANE
 ** FOR SOLDER DIP LEAD FINISH, LEAD DIAMETER IS $0.016 - 0.024$ (0.406 - 0.610)

OBsolete PACKAGE

TYPICAL APPLICATION

Low Noise Infrared Detector

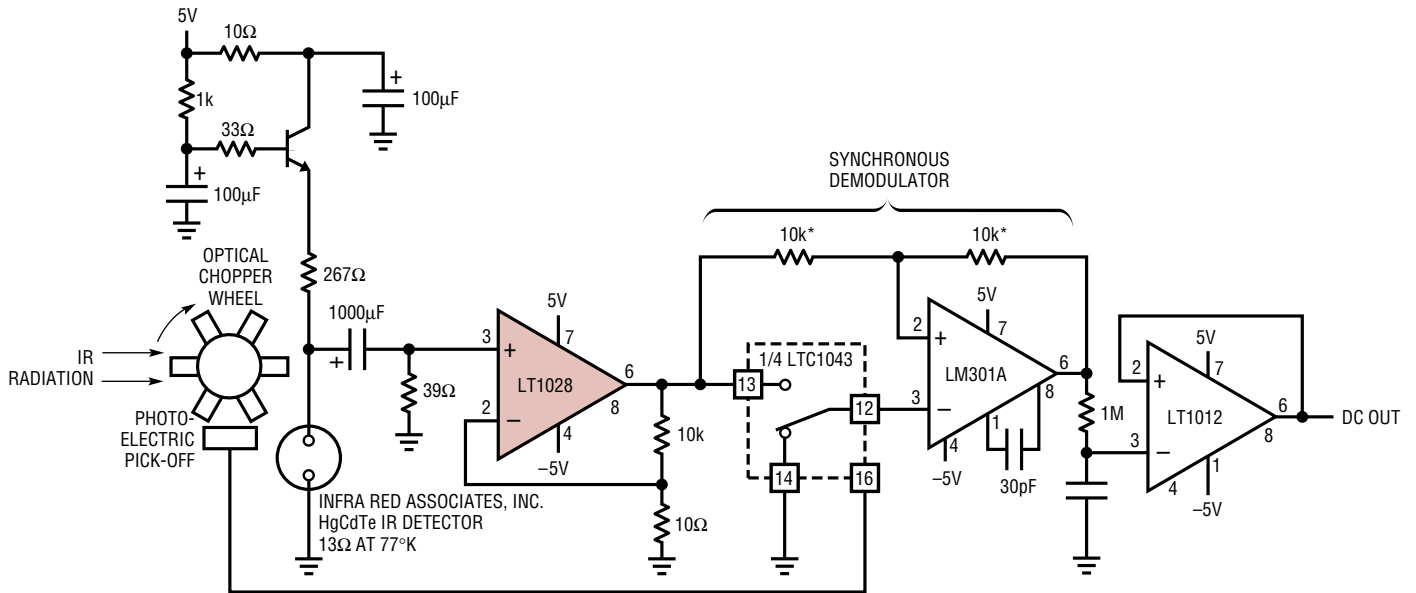

1028/1128 TA12

RELATED PARTS

PART NUMBER	DESCRIPTION	COMMENTS
LT1806/LT1807	325MHz, 3.5nV/√Hz Single and Dual Op Amps	Slew Rate = 140V/μs, Low Distortion at 5MHz: -80dBc