

160-1026 Solder terminal, turreted

Recommended mounting hole .094 (2,37), #42 drill

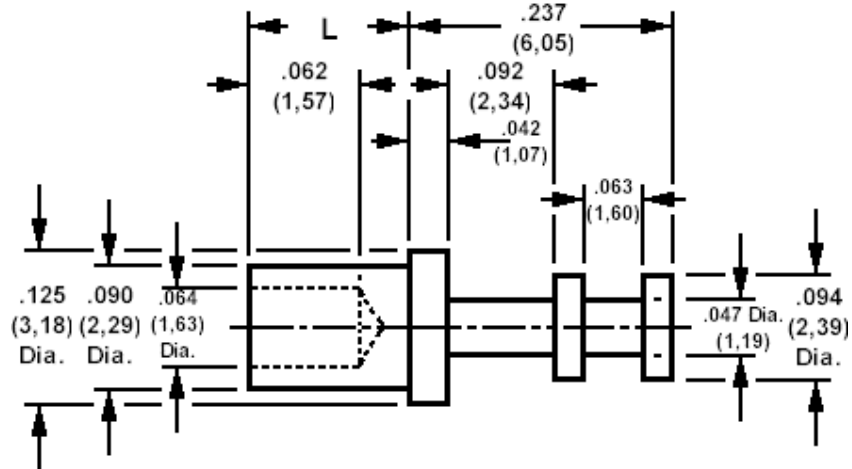

How to order code

160-1026-XX-YY-00

Basic Part No XX = L dimension, YY = Plating Finish

DIMENSIONS (XX)			
Basic Part No	(XX)	L	Board Thickness
160-1026	-01	.075 (1,91)	.031 (0,79)
	-02	.105 (2,67)	.062 (1,58)
	-03	.135 (3,43)	.094 (2,38)
	-04	.165 (4,19)	.125 (3,18)

MATERIALS			
Component	Material	Finish (YY)	
Terminal	Brass	-01	-05
		Silver	Electro Solder

SWAGE TOOLING	
Recommended Swaging Tools:-	
Anvil	435-6404-01-00-00
Roll punch	435-6604-01-00-00
Flare punch	435-6663-01-00-00