

160-1798 Solder terminal, turreted, thru hole

Recommended mounting hole .141 (3,57), #28 drill

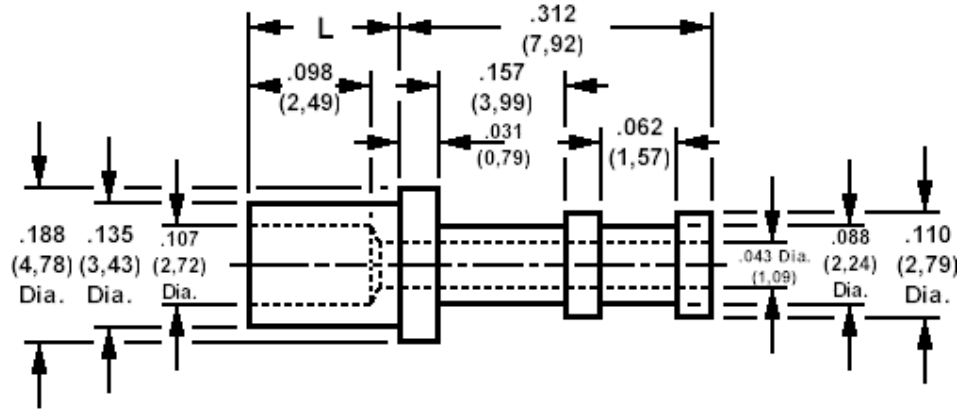

How to order code

160-1798-XX-YY-00

Basic Part No XX = L dimension, YY = Plating Finish

DIMENSIONS (XX)			
Basic Part No	(XX)	L	Board Thickness
160-1798	-02	.109 (2,77)	.062 (1,59)
	-03	.141 (3,58)	.094 (2,38)
	-04	.172 (4,37)	.125 (3,18)

MATERIALS			
Component	Material	Finish (YY)	
Terminal	Brass	-01	-05
		Silver	Electro Solder

SWAGE TOOLING	
Recommended Swaging Tools:-	
Anvil	435-6407-01-00-00
Roll punch	435-6607-01-00-00
Flare punch	435-6664-01-00-00