

Dimensions (Unit: mm)

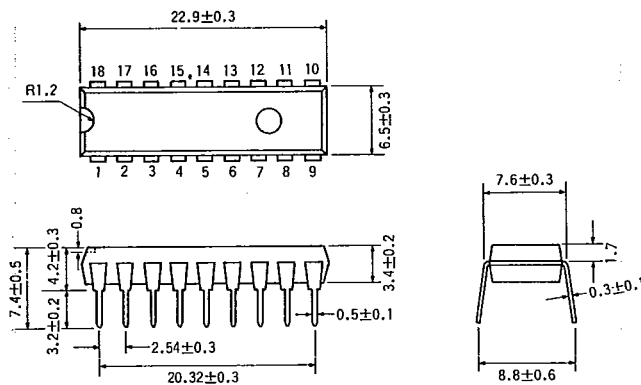

Fig. 1

The BA2266A is a monolithic radio servo controller designed for use in radio-controlled model cars.

With an internal channel divider, the device allows simultaneous control over the steering and motor speed including forward/reverse control. Since the BA2266A directly supplies control signals, energy loss is minimized and battery life is extended. The steering servo is linked to the turning lights. Also when the driving motor is switched to the reverse position, the reverse lights are automatically lit.

Combined with a receiver chip, the BA2266A provides all the functions required for radio-controlled model cars.

Features

1. Internal channel divider.
2. Internal steering servo motor driver and driving motor servo.
3. Turning lights are linked to the steering.
4. Reverse lights are linked to the driving motor.
5. Turning light flashing interval can be varied by an external capacitor.

Applications

- Radio-controlled model cars
- Radio-controlled model motorcycles
- Radio-controlled model boats

Block Diagram

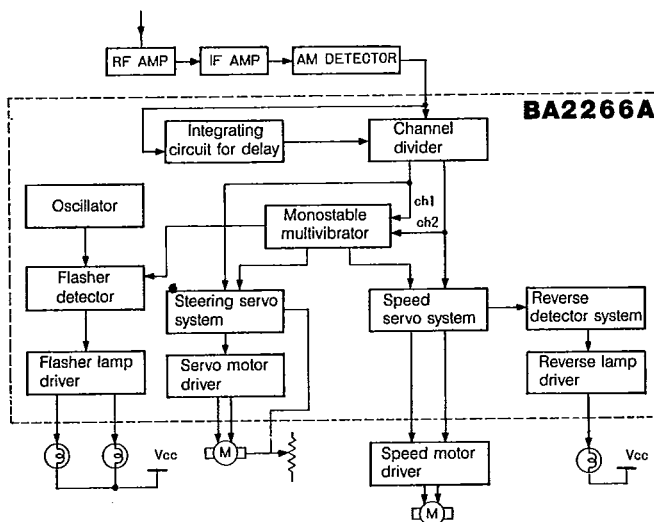

Fig. 2

Absolute Maximum Ratings (Ta=25°C)

Parameter	Symbol	Limits	Unit
Supply voltage	V _{CC}	10	V
Power dissipation	P _d	1100*	mW
Operating temperature range	T _{opr}	-25 ~ 75	°C
Storage temperature range	T _{stg}	-55 ~ 125	°C

*Derating is done at 11mW/°C for operation above Ta=25°C.

Electrical Characteristics (Ta=25°C, V_{CC}=6V)

Parameter	Symbol	Min.	Typ.	Max.	Unit	Conditions	Test circuit
Operating supply voltage	V _{CC}	3.8	6.0	9.5	V	—	Fig. 3
Input threshold voltage	V _{IN}	—	0.7	1.0	V	—	Fig. 3
Quiescent current	I _Q	—	7.0	20	mA	—	Fig. 3
Flasher drive current	I _{w1}	—	—	100	mA	—	Fig. 3
Flasher drive current	I _{w2}	—	—	100	mA	—	Fig. 3
Steering drive current 1	I _{S1-2}	—	—	370	mA	t ₁ > t ₀₁	Fig. 3
Steering drive current 2	I _{S2-1}	—	—	370	mA	t ₁ < t ₀₁	Fig. 3
Reverse lamp drive current	I _B	—	—	100	mA	t ₂ > t ₀₂	Fig. 3

Test Circuit

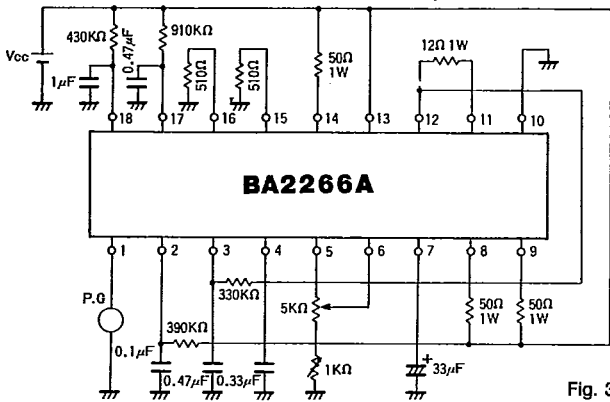
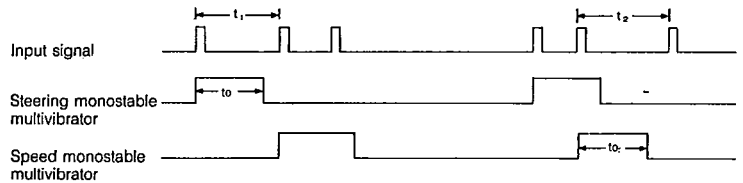

Fig. 3



Application Example

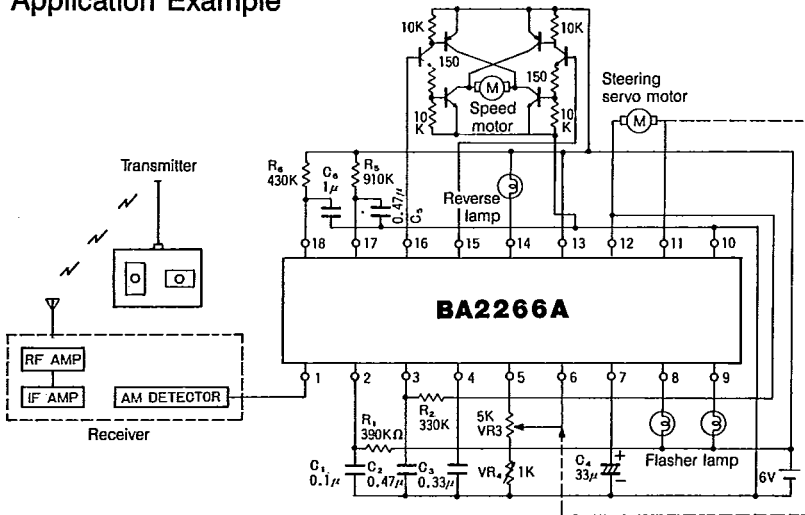
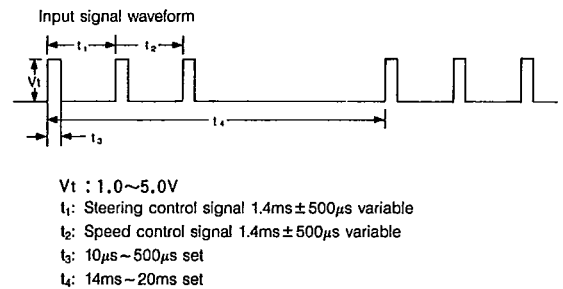

Fig. 4



Description of External Components

R₁/C₁

R₁ and C₁ provide a time constant for the delay integration circuit. C₁ is charged when the input signal is high, and is discharged when it is low. R₁ and C₁ values should be selected so that the C₁ potential does not drop below that before discharging between t₁ and t₂, but returns to it in t₄.

C₂

This capacitor determines the reference pulse width for the steering servo. An internal constant current source is provided for this capacitor. Set the pulse width using the formula, $T=C \cdot V/I$, where $I=100 \mu A$ (typ.) and V is the potential at

pin 6.

C₃

Capacitor C₃ determines the reference pulse width for the driving motor. An internal constant current source is provided for this capacitor. Set the pulse width using the formula, $T=C \cdot V/I$, where $I=120 \mu A$ (typ.) and V is the potential at pin 5.

R₂

Feedback resistor for the driving motor. Select the value of this resistor so that hunting is minimized.

VR₃

Steering servo motor position sensing variable resistor.

VR₄

An internal constant current source is provided at pin 5. This variable resistor is used to adjust the potential at pin 5.

C₄

Capacitor C₄ determines the turning light flashing interval.

R₅/C₅

This RC time constant is used to set the steering servo's stretcher gain.

R₆/C₆

This RC time constant is used to set the driving motor's stretcher gain.

Precautions

The device may malfunction due to motor noise. If the device malfunctions because pin 1, 5, or 6 is affected by motor noise, connect a noise bypassing capacitor to these pins. Also the device may malfunction because the supply line or its return line is affected by the

large load current to the motors or lights. In such a case, it is recommended that the power supply for the device be separated from that for the motors and lights. Also use a single-point ground in the vicinity of the power supply so that the return line will not be affected by

large load currents.

The device may be subject to damage if its lamp or motor driving output is shorted to the supply line. Take special handling care to avoid such an accident.