

APT5025AN	500V	20.0A	0.25 Ω
APT4525AN	450V	20.0A	0.25 Ω
APT5030AN	500V	18.0A	0.30 Ω
APT4530AN	450V	18.0A	0.30 Ω

## POWER MOS IV™

### N - CHANNEL ENHANCEMENT MODE HIGH VOLTAGE POWER MOSFETS

#### MAXIMUM RATINGS

All Ratings:  $T_C = 25^\circ\text{C}$  unless otherwise specified.

Symbol	Parameter	APT				UNIT
		4525AN	5025AN	4530AN	5030AN	
$V_{DSS}$	Drain-Source Voltage	450	500	450	500	Volts
$I_D$	Continuous Drain Current	20		18		Amps
$I_{DM}$	Pulsed Drain Current <sup>1</sup>	80		72		Amps
$V_{GS}$	Gate-Source Voltage	±30				Volts
$P_D$	Total Power Dissipation @ $T_C = 25^\circ\text{C}$ , Derate Above $25^\circ\text{C}$	230				Watts
$T_J, T_{STG}$	Operating and Storage Junction Temperature Range	- 55 to 150				°C

#### STATIC ELECTRICAL CHARACTERISTICS

Symbol	Characteristic / Test Conditions / Part Number	MIN	TYP	MAX	UNIT	
$BV_{DSS}$	Drain-Source Breakdown Voltage ( $V_{GS} = 0V, I_D = 250 \mu\text{A}$ )	APT5025AN / APT5030AN		500	Volts	
		APT4525AN / APT4530AN		450	Volts	
$I_{DSS}$	Zero Gate Voltage Drain Current ( $V_{DS} = V_{DSS}, V_{GS} = 0V$ ) ( $V_{DS} = 0.8 V_{DSS}, V_{GS} = 0V, T_C = 125^\circ\text{C}$ )			250	$\mu\text{A}$	
				1000		
$I_{GSS}$	Gate-Source Leakage Current ( $V_{GS} = \pm 30V, V_{DS} = 0V$ )			±100	nA	
$I_{D(ON)}$	On State Drain Current <sup>2</sup> ( $V_{DS} > I_{D(ON)} \times R_{DS(ON)} \text{ Max}, V_{GS} = 10V$ )	APT5025AN / APT4525AN		20	Amps	
		APT5030AN / APT4530AN		18	Amps	
$V_{GS(TH)}$	Gate Threshold Voltage ( $V_{DS} = V_{GS}, I_D = 1\text{mA}$ )	2		4	Volts	
$R_{DS(ON)}$	Static Drain-Source On-State Resistance <sup>2</sup> ( $V_{GS} = 10V, I_D = 0.5 I_D \text{ [Cont.]}$ )	APT5025AN / APT4525AN			0.25	Ohms
		APT5030AN / APT4530AN			0.30	Ohms

#### THERMAL CHARACTERISTICS

Symbol	Characteristic	MIN	TYP	MAX	UNIT
$R_{\theta JC}$	Junction to Case			0.53	°C/W
$R_{\theta JA}$	Junction to Ambient			30	°C/W
$T_L$	Max. Lead Temp. for Soldering Conditions: 0.063" from Case for 10 Sec.			300	°C

405 S.W. COLUMBIA STREET  
BEND, OREGON 97702-1035  
U.S.A.

PHONE ... (503) 382-8028

FAX ..... (503) 388-0364

**DYNAMIC CHARACTERISTICS**

APT5025/4525/5030/4530AN

Symbol	Characteristic	Test Conditions	MIN	TYP	MAX	UNIT
$C_{iss}$	Input Capacitance	$V_{GS} = 0V$ $V_{DS} = 25V$ $f = 1\text{ MHz}$		2380	2950	pF
$C_{oss}$	Output Capacitance			522	730	pF
$C_{rss}$	Reverse Transfer Capacitance			196	290	pF
$Q_g$	Total Gate Charge <sup>3</sup>	$V_{GS} = 10V, I_D = I_D [\text{Cont.}]$ $V_{DD} = 0.5 V_{DSS}$		83	130	nC
$Q_{gs}$	Gate-Source Charge			12.6	19	nC
$Q_{gd}$	Gate-Drain ("Miller") Charge			51	76	nC
$t_d(\text{on})$	Turn-on Delay Time	$V_{DD} = 0.5 V_{DSS}$ $I_D = I_D [\text{Cont.}], V_{GS} = 15V$ $R_G = 1.8$		14	28	ns
$t_r$	Rise Time			27	55	ns
$t_d(\text{off})$	Turn-off Delay Time			61	92	ns
$t_f$	Fall Time			36	71	ns

**SOURCE-DRAIN DIODE RATINGS AND CHARACTERISTICS**

T-39-15

Symbol	Characteristic / Test Conditions / Part Number	MIN	TYP	MAX	UNIT
$I_S$	Continuous Source Current (Body Diode)	APT5025AN / APT4525AN		20	Amps
		APT5030AN / APT4530AN		18	Amps
$I_{SM}$	Pulsed Source Current <sup>1</sup> (Body Diode)	APT5025AN / APT4525AN		80	Amps
		APT5030AN / APT4530AN		72	Amps
$V_{SD}$	Diode Forward Voltage <sup>2</sup> ( $V_{GS} = 0V, I_S = -I_D [\text{Cont.}]$ )			1.3	Volts
$t_{rr}$	Reverse Recovery Time ( $I_S = -I_D [\text{Cont.}], di_S/dt = 100A/\mu s$ )	160	320	640	ns
$Q_{rr}$	Reverse Recovery Charge	2.7	5.5	11	$\mu C$

**SAFE OPERATING AREA CHARACTERISTICS**

Symbol	Characteristic	Test Conditions / Part Number	MIN	TYP	MAX	UNIT
SOA1	Safe Operating Area	$V_{DS} = 0.4 V_{DSS}, I_{DS} = P_D / 0.4 V_{DSS}, t = 1\text{ Sec.}$	230			Watts
SOA2	Safe Operating Area	$I_{DS} = I_D [\text{Cont.}], V_{DS} = P_D / I_D [\text{Cont.}], t = 1\text{ Sec.}$	230			Watts
$I_{LM}$	Inductive Current Clamped	APT5025AN / APT4525AN	80			Amps
		APT5030AN / APT4530AN	72			Amps

1.) Repetitive Rating: Pulse width limited by maximum junction temperature. See Transient Thermal Impedance Curve. (Fig.1)

2.) Pulse Test: Pulse width < 380  $\mu s$   
Duty Cycle < 2%  
3.) See MIL-STD-750 Method 3471

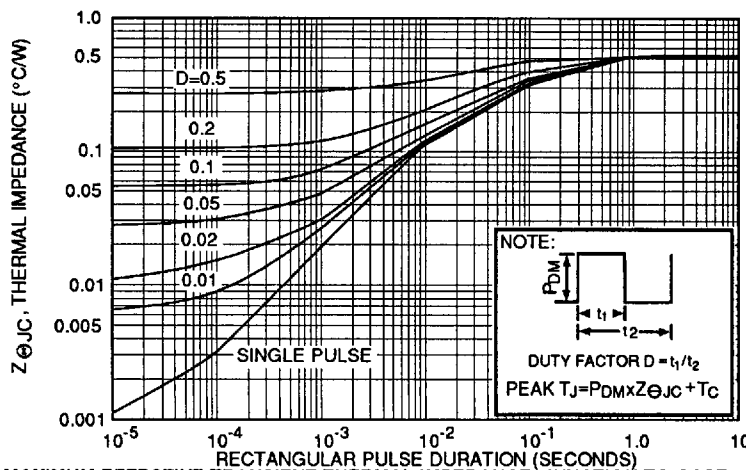

FIGURE 1, MAXIMUM EFFECTIVE TRANSIENT THERMAL IMPEDANCE, JUNCTION-TO-CASE vs PULSE DURATION

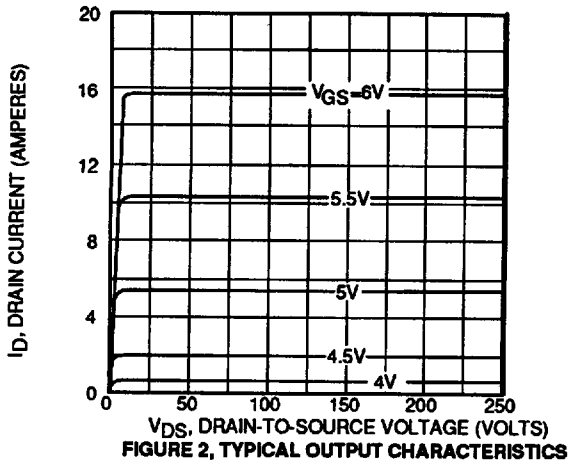

FIGURE 2, TYPICAL OUTPUT CHARACTERISTICS

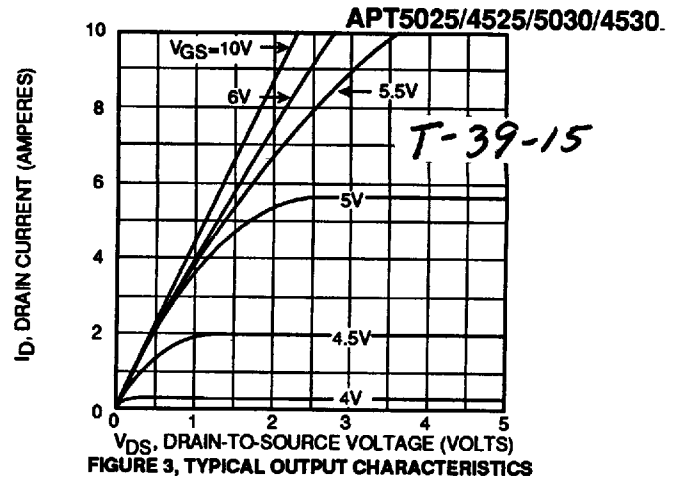

FIGURE 3, TYPICAL OUTPUT CHARACTERISTICS

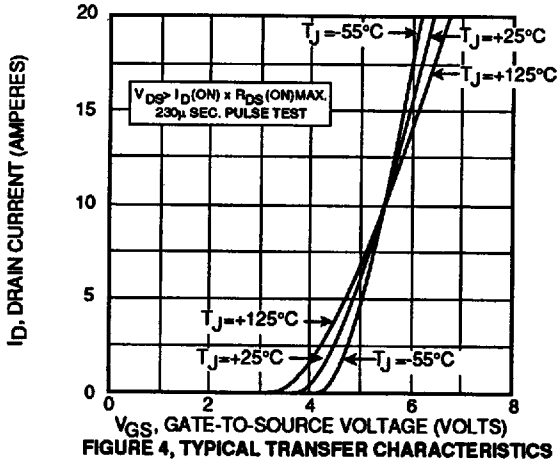

FIGURE 4, TYPICAL TRANSFER CHARACTERISTICS

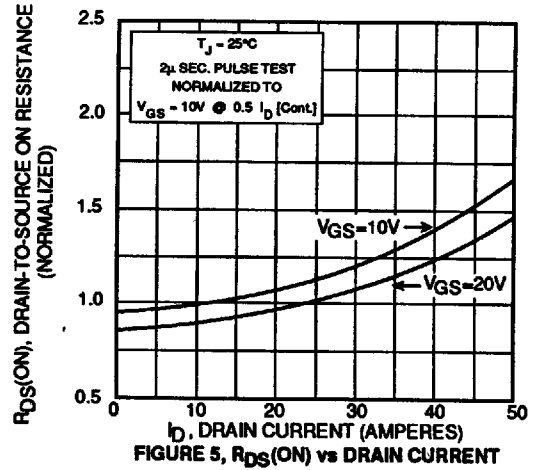

FIGURE 5,  $R_{DS(ON)}$  vs DRAIN CURRENT

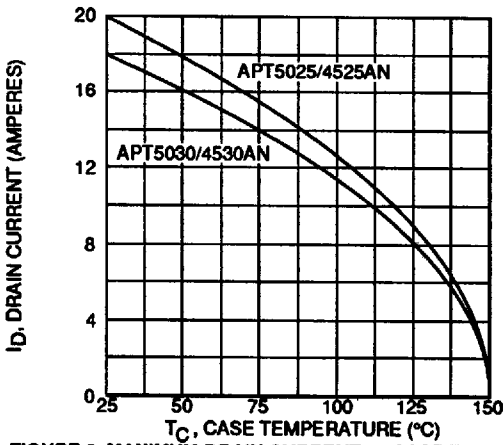

FIGURE 6, MAXIMUM DRAIN CURRENT vs CASE TEMPERATURE

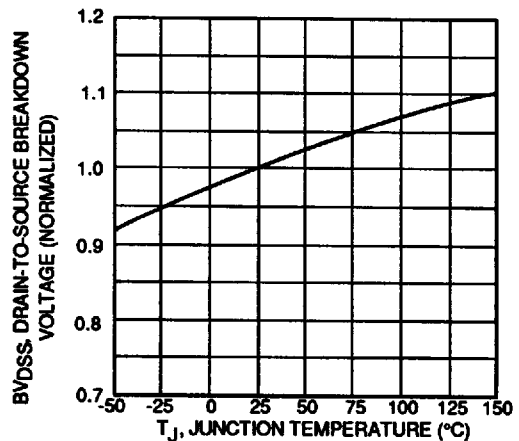

FIGURE 7, BREAKDOWN VOLTAGE vs TEMPERATURE

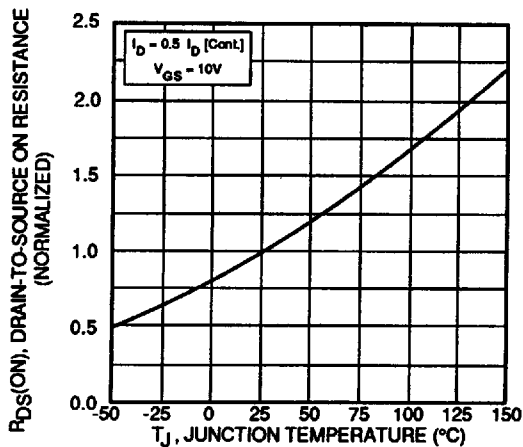

FIGURE 8, ON-RESISTANCE vs. TEMPERATURE

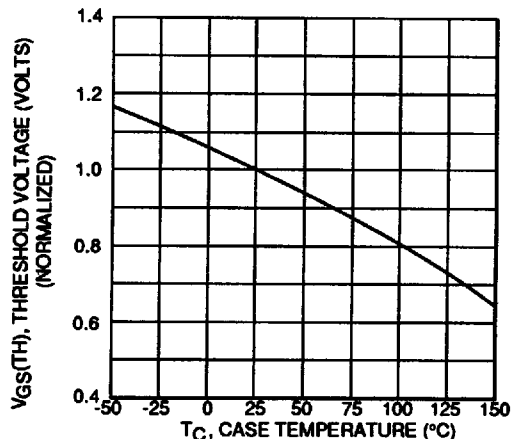

FIGURE 9, THRESHOLD VOLTAGE vs TEMPERATURE

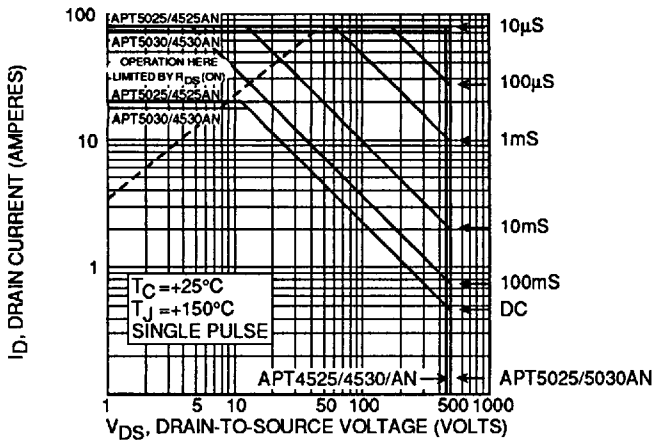

FIGURE 10, MAXIMUM SAFE OPERATING AREA

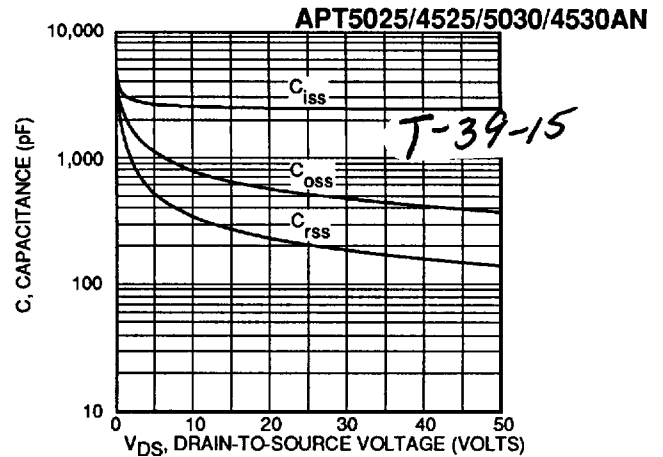

FIGURE 11, TYPICAL CAPACITANCE vs DRAIN-TO-SOURCE VOLTAGE

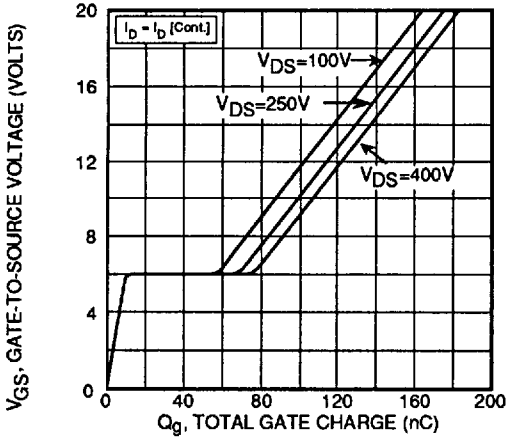

FIGURE 12, GATE CHARGES vs GATE-TO-SOURCE VOLTAGE

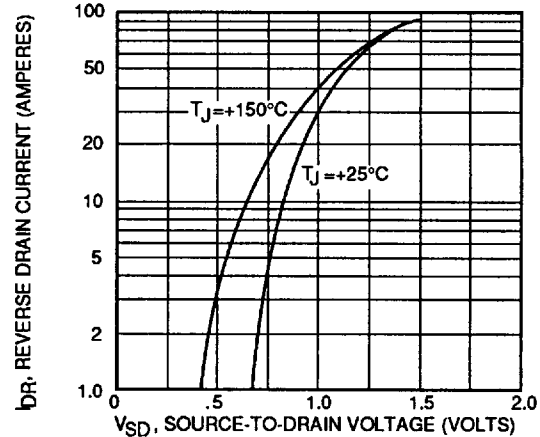
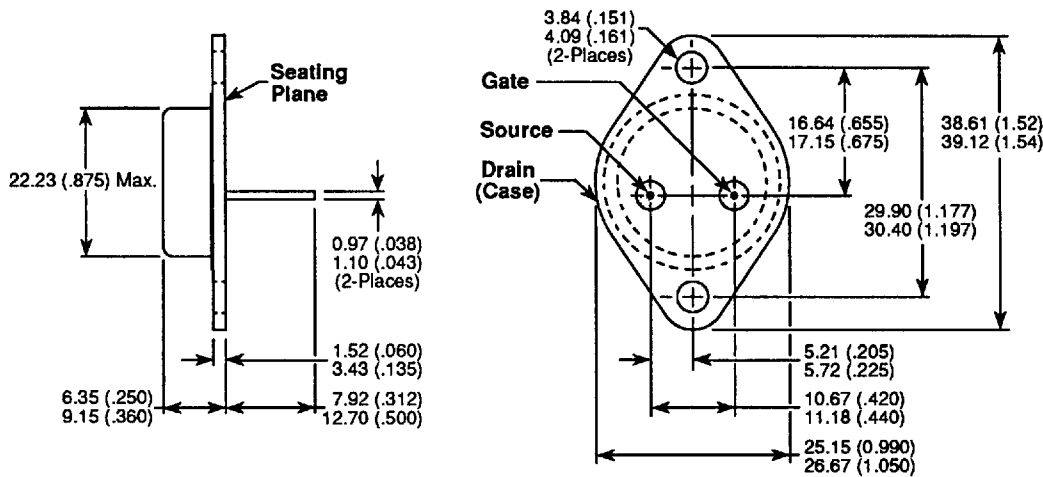

FIGURE 13, TYPICAL SOURCE-DRAIN DIODE FORWARD VOLTAGE

TO-3 Package Outline (TO-204AA)



Dimensions in Millimeters and (Inches)