

**3 Phase bridge
NPT IGBT Power Module**

**$V_{CES} = 1700V$
 $I_C = 75A @ T_c = 80^\circ C$**

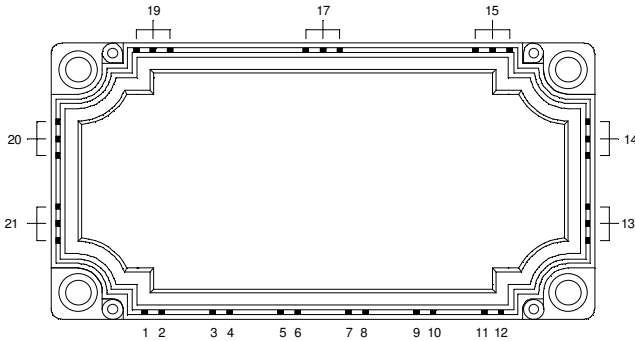
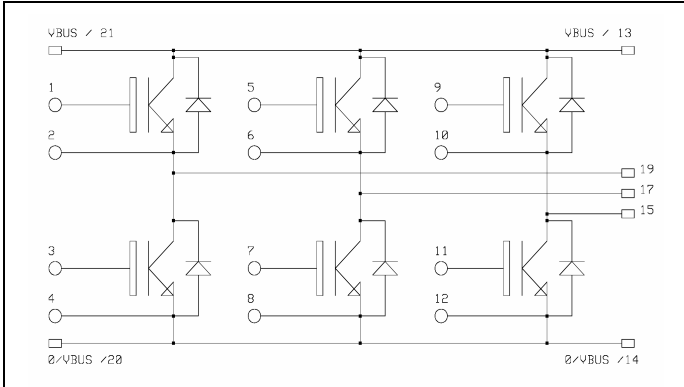

Application

- AC Motor control

Features

- Non Punch Through (NPT) Low Loss IGBT®
 - Low voltage drop
 - Low tail current
 - Switching frequency up to 20 kHz
 - Soft recovery parallel diodes
 - Low diode VF
 - Low leakage current
 - Avalanche energy rated
 - RBSOA and SCSOA rated
- Kelvin emitter for easy drive
- Very low stray inductance
- High level of integration

Benefits

- Stable temperature behavior
- Very rugged
- Solderable terminals for easy PCB mounting
- Direct mounting to heatsink (isolated package)
- Low junction to case thermal resistance
- Easy paralleling due to positive TC of VCEsat
- Low profile

Absolute maximum ratings

Symbol	Parameter	Max ratings	Unit
V_{CES}	Collector - Emitter Breakdown Voltage	1700	V
I_C	Continuous Collector Current	$T_C = 25^\circ C$	150
		$T_C = 80^\circ C$	75
I_{CM}	Pulsed Collector Current	$T_C = 25^\circ C$	250
V_{GE}	Gate - Emitter Voltage	± 20	V
P_D	Maximum Power Dissipation	$T_C = 25^\circ C$	625
RBSOA	Reverse Bias Operating Area	$T_j = 125^\circ C$	150A@1600V

CAUTION: These Devices are sensitive to Electrostatic Discharge. Proper Handling Procedures Should Be Followed.

Electrical Characteristics

All ratings @ $T_j = 25^\circ\text{C}$ unless otherwise specified

Symbol	Characteristic	Test Conditions	Min	Typ	Max	Unit
BV_{CES}	Collector - Emitter Breakdown Voltage	$V_{GE} = 0V, I_C = 1mA$	1700			V
I_{CES}	Zero Gate Voltage Collector Current	$V_{GE} = 0V$ $V_{CE} = 1700V$	$T_j = 25^\circ\text{C}$	0.03	0.15	mA
			$T_j = 125^\circ\text{C}$	2		
$V_{CE(on)}$	Collector Emitter on Voltage	$V_{GE} = 15V$ $I_C = 75A$	$T_j = 25^\circ\text{C}$	2.7	3.3	V
			$T_j = 125^\circ\text{C}$	3.2		
$V_{GE(th)}$	Gate Threshold Voltage	$V_{GE} = V_{CE}, I_C = 3.5 mA$	4.5		6.5	V
I_{GES}	Gate - Emitter Leakage Current	$V_{GE} = 20V, V_{CE} = 0V$			100	nA

Dynamic Characteristics

Symbol	Characteristic	Test Conditions	Min	Typ	Max	Unit
C_{ies}	Input Capacitance	$V_{GE} = 0V, V_{CE} = 25V$ $f = 1MHz$		5000		pF
$T_{d(on)}$	Turn-on Delay Time	Inductive Switching (25°C) $V_{GE} = \pm 15V$ $V_{Bus} = 900V$ $I_C = 75A$ $R_G = 20\Omega$		100		ns
T_r	Rise Time			100		
$T_{d(off)}$	Turn-off Delay Time			800		
T_f	Fall Time			30		
$T_{d(on)}$	Turn-on Delay Time	Inductive Switching (125°C) $V_{GE} = \pm 15V$ $V_{Bus} = 900V$ $I_C = 75A$ $R_G = 20\Omega$		100		ns
T_r	Rise Time			100		
$T_{d(off)}$	Turn-off Delay Time			900		
T_f	Fall Time			30		
E_{off}	Turn off Energy			22		mJ

Reverse diode ratings and characteristics

Symbol	Characteristic	Test Conditions	Min	Typ	Max	Unit
V_F	Diode Forward Voltage	$I_F = 75A$ $V_{GE} = 0V$	$T_j = 25^\circ\text{C}$	2.2	2.6	V
			$T_j = 125^\circ\text{C}$	2.0		
E_r	Reverse Recovery Energy	$I_F = 75A$ $V_R = 900V$ $di/dt = 900A/\mu s$	$T_j = 25^\circ\text{C}$	3.5		mJ
			$T_j = 125^\circ\text{C}$	6.5		
Q_{rr}	Reverse Recovery Charge	$I_F = 75A$ $V_R = 900V$ $di/dt = 900A/\mu s$	$T_j = 25^\circ\text{C}$	9		μC
			$T_j = 125^\circ\text{C}$	19		

Thermal and package characteristics

Symbol	Characteristic	Min	Typ	Max	Unit	
R_{thJC}	Junction to Case	IGBT		0.2	$^\circ\text{C/W}$	
		Diode		0.47		
V_{ISOL}	RMS Isolation Voltage, any terminal to case $t = 1$ min, $I_{isol} < 1mA, 50/60Hz$	2500			V	
T_j	Operating junction temperature range	-40		150	$^\circ\text{C}$	
T_{STG}	Storage Temperature Range	-40		125		
T_C	Operating Case Temperature	-40		125		
Torque	Mounting torque	To Heatsink	M5	3		4.5
Wt	Package Weight				300	g

