

3 Phase bridge NPT IGBT Power Module

$V_{CES} = 1700V$
 $I_C = 50A @ T_c = 80^\circ C$

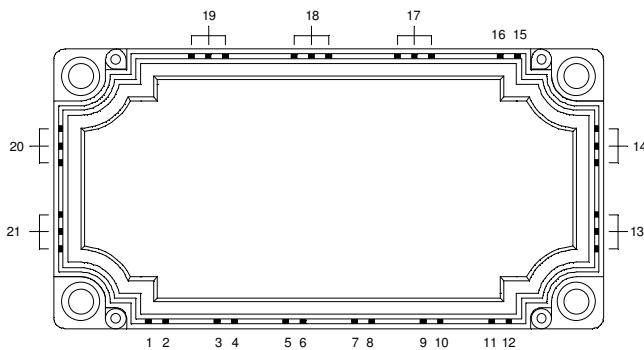
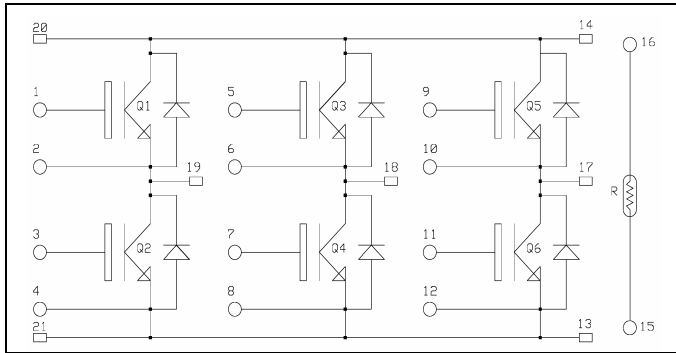

Application

- AC Motor control

Features

- Non Punch Through (NPT) Low Loss IGBT®
 - Low voltage drop
 - Low tail current
 - Switching frequency up to 20 kHz
 - Soft recovery parallel diodes
 - Low diode VF
 - Low leakage current
 - Avalanche energy rated
 - RBSOA and SCSOA rated
- Kelvin emitter for easy drive
- Very low stray inductance
- High level of integration
- Internal thermistor for temperature monitoring

Benefits

- Stable temperature behavior
- Very rugged
- Solderable terminals for easy PCB mounting
- Direct mounting to heatsink (isolated package)
- Low junction to case thermal resistance
- Easy paralleling due to positive TC of VCEsat
- Low profile

Absolute maximum ratings

Symbol	Parameter	Max ratings	Unit
V_{CES}	Collector - Emitter Breakdown Voltage	1700	V
I_C	Continuous Collector Current	$T_C = 25^\circ C$	100
		$T_C = 80^\circ C$	50
I_{CM}	Pulsed Collector Current	$T_C = 25^\circ C$	150
V_{GE}	Gate - Emitter Voltage	± 20	V
P_D	Maximum Power Dissipation	$T_C = 25^\circ C$	480
RBSOA	Reverse Bias Operating Area	$T_j = 125^\circ C$	100A@1600V

 **CAUTION:** These Devices are sensitive to Electrostatic Discharge. Proper Handling Procedures Should Be Followed.

Electrical Characteristics

All ratings @ $T_j = 25^\circ\text{C}$ unless otherwise specified

Symbol	Characteristic	Test Conditions	Min	Typ	Max	Unit
BV_{CES}	Collector - Emitter Breakdown Voltage	$V_{GE} = 0V, I_C = 1mA$	1700			V
I_{CES}	Zero Gate Voltage Collector Current	$V_{GE} = 0V$		0.02	0.1	mA
		$V_{CE} = 1700V$		1.5		
$V_{CE(on)}$	Collector Emitter on Voltage	$V_{GE} = 15V$		2.7	3.3	V
		$I_C = 50A$		3.2		
$V_{GE(th)}$	Gate Threshold Voltage	$V_{GE} = V_{CE}, I_C = 2.5 mA$	4.5		6.5	V
I_{GES}	Gate - Emitter Leakage Current	$V_{GE} = 20V, V_{CE} = 0V$			100	nA

Dynamic Characteristics

Symbol	Characteristic	Test Conditions	Min	Typ	Max	Unit
C_{ies}	Input Capacitance	$V_{GE} = 0V, V_{CE} = 25V$ $f = 1MHz$		3500		pF
$T_{d(on)}$	Turn-on Delay Time	Inductive Switching (25°C) $V_{GE} = \pm 15V$ $V_{Bus} = 900V$ $I_C = 50A$ $R_G = 30\Omega$		100		ns
T_r	Rise Time			100		
$T_{d(off)}$	Turn-off Delay Time			800		
T_f	Fall Time			30		
$T_{d(on)}$	Turn-on Delay Time	Inductive Switching (125°C) $V_{GE} = \pm 15V$ $V_{Bus} = 900V$ $I_C = 50A$ $R_G = 30\Omega$		100		ns
T_r	Rise Time			100		
$T_{d(off)}$	Turn-off Delay Time			900		
T_f	Fall Time			30		
E_{off}	Turn off Energy			14.5		mJ

Reverse diode ratings and characteristics

Symbol	Characteristic	Test Conditions	Min	Typ	Max	Unit
V_F	Diode Forward Voltage	$I_F = 50A$		2.2	2.6	V
		$V_{GE} = 0V$		2.0		
E_r	Reverse Recovery Energy	$I_F = 50A$		2		mJ
		$V_R = 900V$ $di/dt = 750A/\mu s$		4		
Q_{rr}	Reverse Recovery Charge	$I_F = 50A$		6		μC
		$V_R = 900V$ $di/dt = 750A/\mu s$		12		

Temperature sensor NTC

Symbol	Characteristic	Min	Typ	Max	Unit
R_{25}	Resistance @ 25°C		5		k Ω
$B_{25/50}$	$T_{25} = 298.16 K$		3375		K

$$R_T = \frac{R_{25}}{\exp\left[B_{25/50}\left(\frac{1}{T_{25}} - \frac{1}{T}\right)\right]}$$

T: Thermistor temperature
R_T: Thermistor value at T

Thermal and package characteristics

Symbol	Characteristic	Min	Typ	Max	Unit	
R _{thJC}	Junction to Case	IGBT		0.26	°C/W	
		Diode		0.56		
V _{ISOL}	RMS Isolation Voltage, any terminal to case t =1 min, I _{isol} < 1mA, 50/60Hz	2500			V	
T _J	Operating junction temperature range	-40		150	°C	
T _{STG}	Storage Temperature Range	-40		125		
T _C	Operating Case Temperature	-40		125		
Torque	Mounting torque	To Heatsink	M5	3	4.5	N.m
Wt	Package Weight				300	g

Package outline

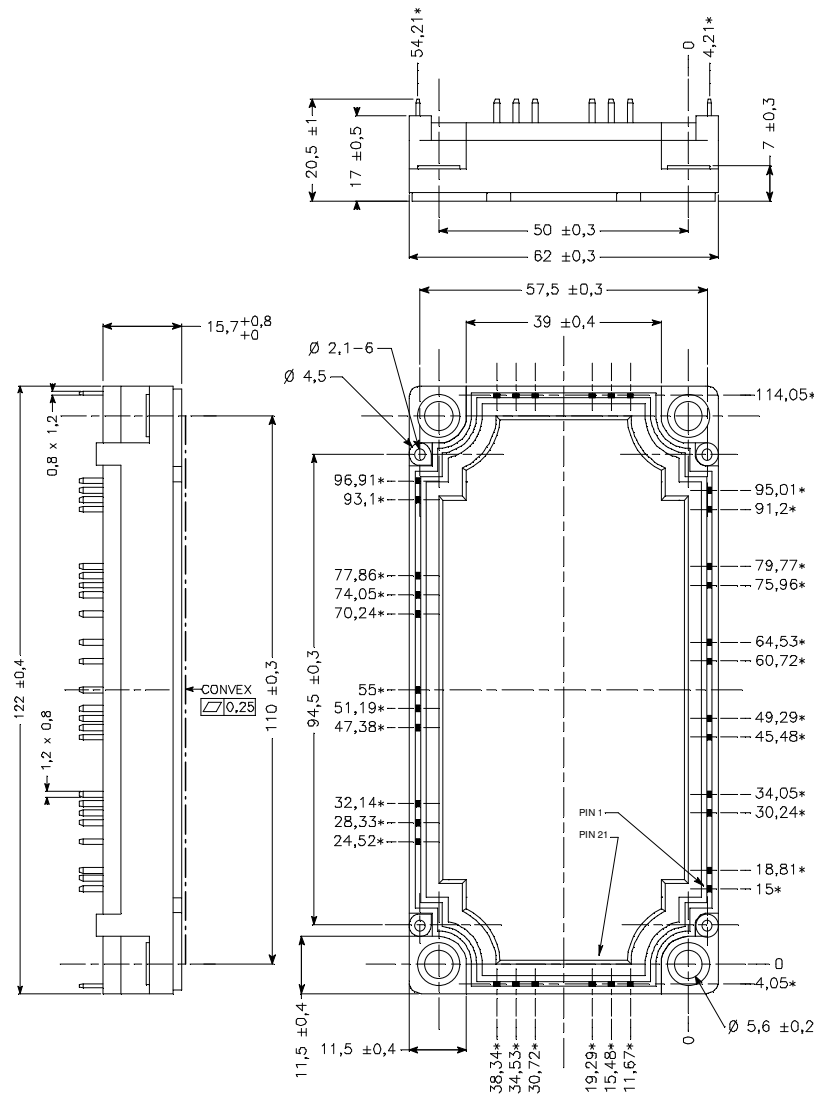

ALL DIMENSIONS MARKED * * * ARE TOLERANCED AS : $\oplus \ominus 0,4$

APT reserves the right to change, without notice, the specifications and information contained herein

APT's products are covered by one or more of U.S patents 4,895,810 5,045,903 5,089,434 5,182,234 5,019,522 5,262,336 6,503,786 5,256,583 4,748,103 5,283,202 5,231,474 5,434,095 5,528,058 and foreign patents. U.S and Foreign patents pending. All Rights Reserved.