

Features

- Very Low Dropout Voltage
- Low Current Consumption: Typ. 50µA
- Output Voltage: 3.3V
- Guaranteed 500mA (min) Output
- Input Range up to 5.5V
- Current Limiting
- Stable with either electrolytic capacitor or low-ESR MLCC (multi-layer ceramic capacitor) Low Temperature Coefficient
- SOP-8L: Available in "Green" Molding Compound (No Br, Sb)
- Lead Free Finish / RoHS Compliant (Note 1)

General Description

The AP7217 low-dropout linear regulator operates from a 3.3V to 5.5V supply and delivers a guaranteed 500mA (min) continuous load current.

The high-accuracy output voltage is preset to an internally trimmed voltage. An active-low open-drain reset output remains asserted for at least 20ms (TYP) after output voltage reaches V_{DF} .

The space-saving SOP-8L package is suitable for "pocket" and hand-held applications.

Applications

- HD/BlueRay DVD & MP3/4 Players
- Mobile Handsets and Smartphones
- Digital Still Camera
- Hand-Held Computers

Ordering Information

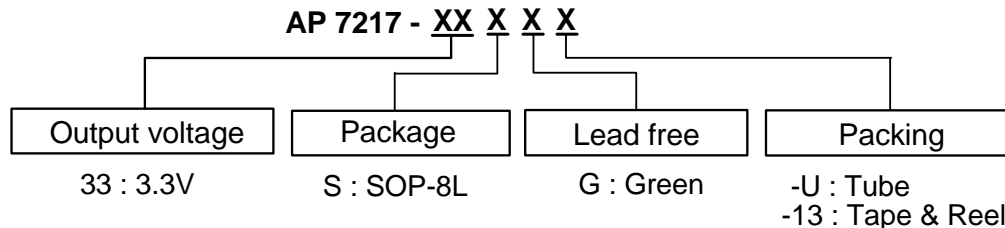

Device	Package Code	Packaging (Note 2)	Tube		13" Tape and Reel	
			Quantity	Part Number Suffix	Quantity	Part Number Suffix
AP7217-XXS	S	SOP-8L	100	-U	2500/Tape & Reel	-13

Notes: 1. EU Directive **2002/95/EC** (RoHS). All applicable RoHS exemptions applied, see *EU Directive 2002/95/EC Annex Notes*.
 2. Pad layout as shown on Diodes Inc. suggested pad layout document AP02001, which can be on our website at <http://www.diodes.com/datasheets/ap02001.pdf>.

Pin Assignments

Pin Descriptions

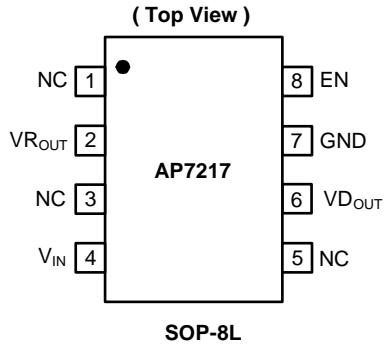

Pin Name	Pin No.	Function
NC	1	No Connection
VR _{OUT}	2	Voltage Output
NC	3	No Connection
V _{IN}	4	Supply Voltage
NC	5	No connection
VD _{OUT}	6	V _D Output (Reset on I/P)
GND	7	Ground
EN	8	Enable (V _R On/Off)

Block Diagram

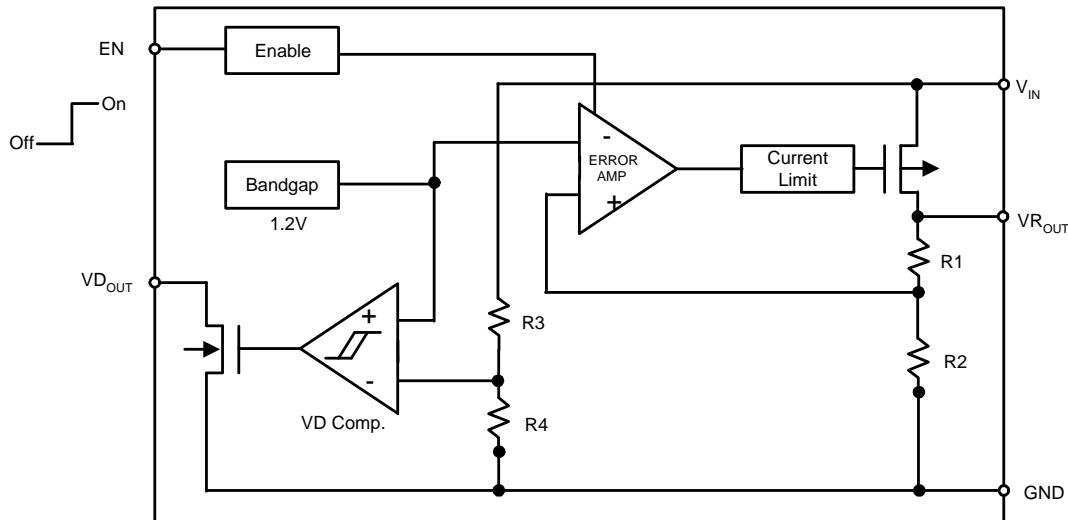

Absolute Maximum Ratings

Symbol	Parameter	Rating	Unit
ESD HBM	Human Body Model ESD Protection	2	KV
ESD MM	Machine Model ESD Protection	450	V
V _{IN}	Input Voltage	+6	V
I _{OUT}	Output Current	P _D / (V _{IN} -V _O)	mA
VR _{OUT}	Output Voltage	GND - 0.3 ~ V _{IN} + 0.3	V
T _J	Operating Junction Temperature Range	-40 to +125	°C
T _{J(MAX)}	Maximum Junction Temperature	150	°C
P _D	Internal Power Dissipation	1.2	W

Recommended Operating Conditions

Symbol	Parameter	Min	Max	Unit
V_{IN}	Input Voltage	3.3	5.5	V
I_{OUT}	Output Current	0	500	mA
T_A	Operating Ambient Temperature	-40	85	°C

Electrical Characteristics

($T_A = 25^\circ\text{C}$, $C_{IN} = 1\mu\text{F}$, $C_{OUT} = 1\mu\text{F}$, $V_{EN} = V_{IN}$, unless otherwise noted)

Symbol	Parameter	Test Conditions	Min	Typ.	Max	Unit
I_Q	Quiescent Current	$I_O = 0\text{mA}$	-	50	70	μA
I_{STB}	Standby Current	$V_{EN} = \text{Off}$ $V_{IN} = 5.0\text{V}$		15	30	μA
VR_{OUT}	Output Voltage Accuracy	$I_O = 30\text{mA}$, $V_{IN} = 5\text{V}$	3.234	3.300	3.366	V
	VR_{OUT} Temperature Coefficient	-40°C to 85°C , $I_{OUT} = 30\text{mA}$		± 100		ppm / °C
$V_{DROPOUT}$	Dropout Voltage	$I_{OUT} = 100\text{mA}$		100	250	mV
I_{OUT}	Maximum Output Current	$V_{IN} = 5.3\text{V}$	500			mA
I_{LIMIT}	Current Limit	$V_{IN} = 5.3\text{V}$		600		mA
I_{short}	Short Circuit Current	$V_{IN} = 5.3\text{V}$		50		mA
$\Delta V_{LINE}/\Delta V_{IN}/VR_{OUT}$	Line Regulation	$4.3\text{V} \leq V_{IN} \leq 5.5\text{V}$; $I_{OUT} = 30\text{mA}$		0.01	± 0.2	%/V
ΔVR_{OUT}	Load Regulation	$1\text{mA} \leq I_{OUT} \leq 100\text{mA}$, $V_{IN} = 5.3\text{V}$		15	50	mV
PSRR	Power Supply Rejection	$V_{IN} = 4.3\text{V} + 0.5\text{Vp-pAC}$, $I_{OUT} = 50\text{mA}$, $F = 1\text{KHz}$		55		dB
V_{EH}	EN Input Threshold	Output ON	1.6			V
V_{EL}		Output OFF			0.25	V
I_{EN}	Enable Pin Current		-0.1		0.1	μA
V_{DF}	Detect fall voltage		3.83	3.91	3.98	V
$V_{Hysteresis}$	V_D Hysteresis Range		$V_{DF} \times 1.02$	$V_{DF} \times 1.05$	$V_{DF} \times 1.08$	V
IV_{DOUT}	VD Supply Current	$V_{DOUT} = 0.5\text{V}$ $V_{IN} = 2.0\text{V}$ 3.0V		20 30		mA
t_{RP}	V_{DOUT} Delay Time	$V_{IN} = 1.8\text{V}$ to $V_{DF} + 1\text{V}$	10	20	40	mSec
θ_{JA}	Thermal Resistance	SOP-8L (Note 3)		134		°C/W
θ_{JC}	Thermal Resistance	SOP-8L (Note 3)		28		°C/W

Notes: 3. Test conditions for SOP-8L: Devices mounted on FR-4 PC board, MRP, 2oz copper layout, calibrate at $T_J = 150^\circ\text{C}$, measure at $T_A = 25^\circ\text{C}$, minimum recommended pad layout

Typical Application

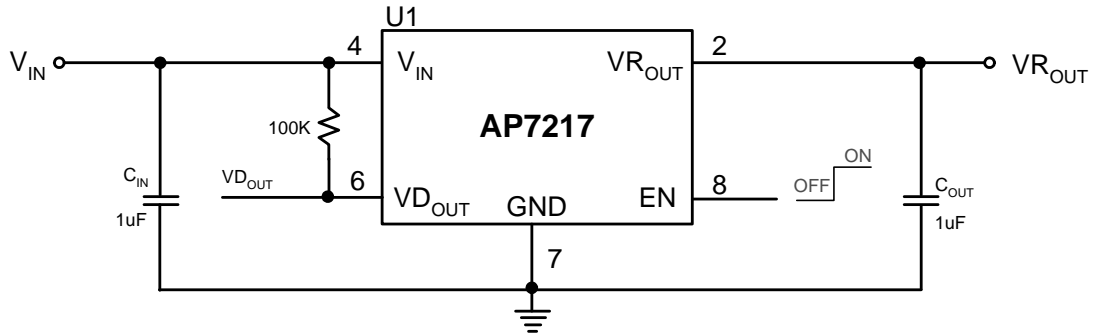

Typical Performance Characteristics

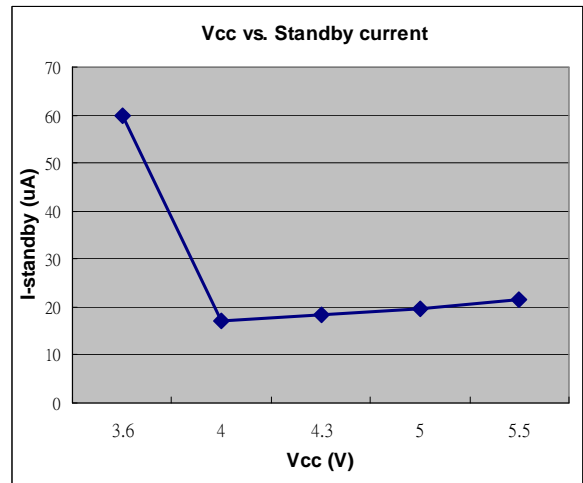
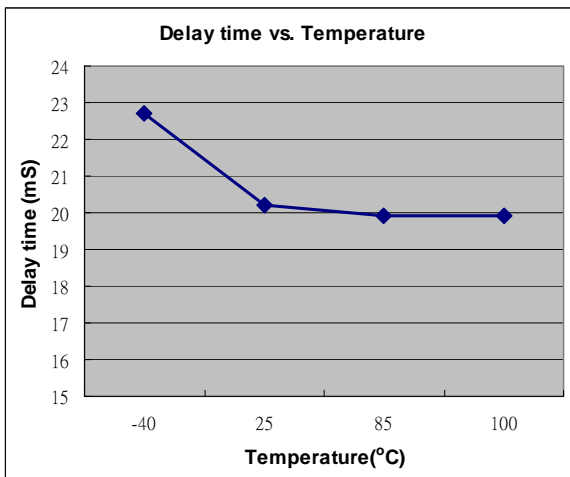
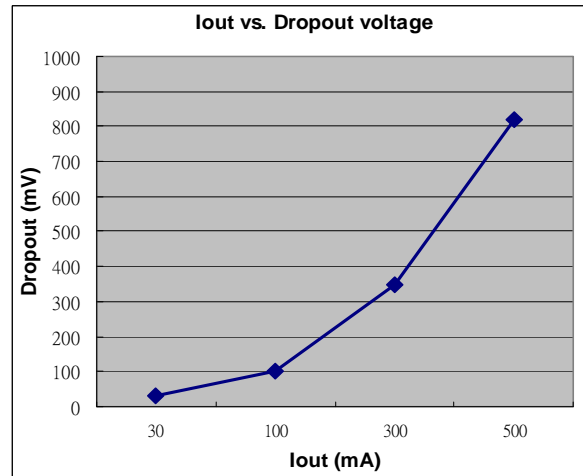
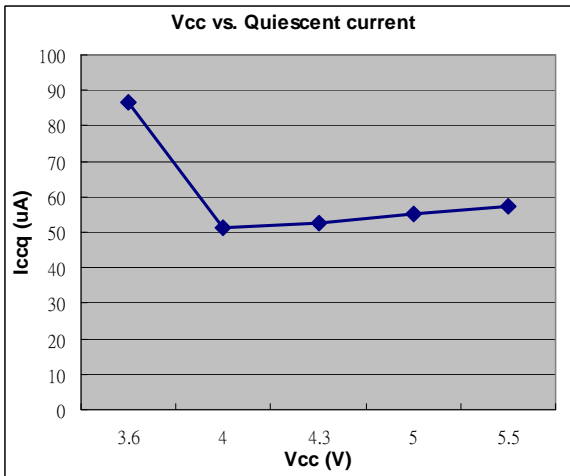

Typical Performance Characteristics (Continued)

Load Transient Response
($V_{IN}=4.3V$, $I_{OUT}=0\sim 500mA$)

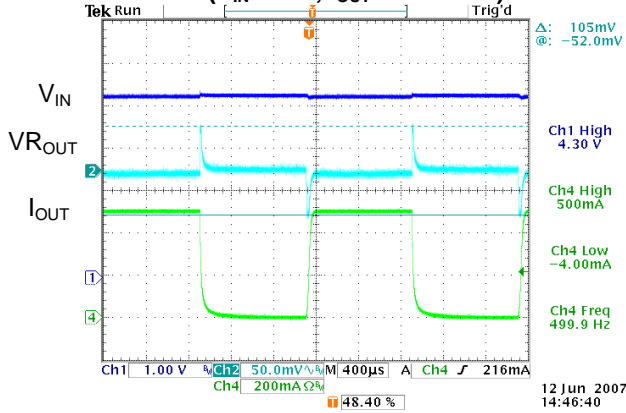

Load Transient Response
($V_{IN}=5.5V$, $I_{OUT}=0\sim 500mA$)

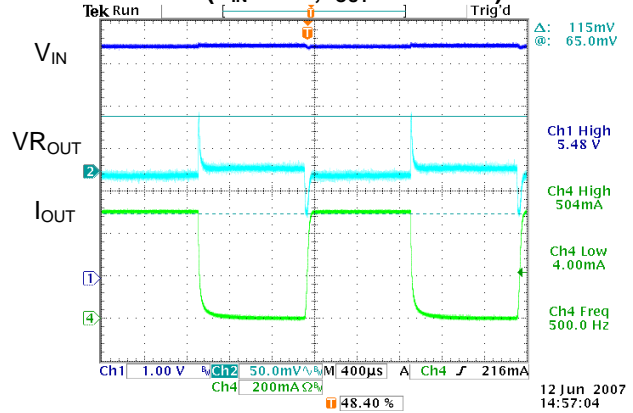

Load Transient Response
($V_{IN}=4.3V$, $I_{OUT}=100\sim 300mA$)

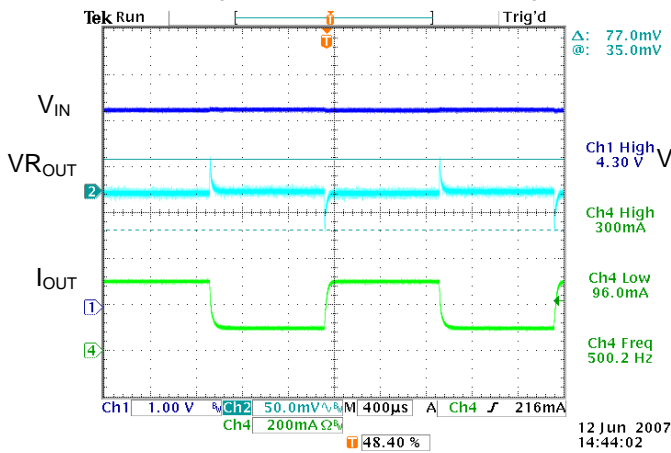

Load Transient Response
($V_{IN}=5.5V$, $I_{OUT}=100\sim 300mA$)

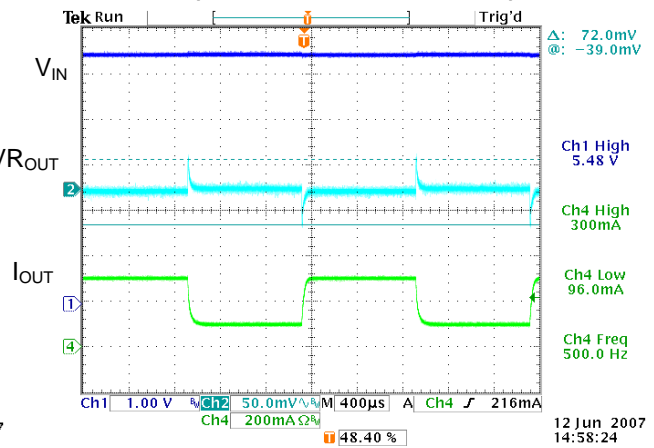

Timing Diagram

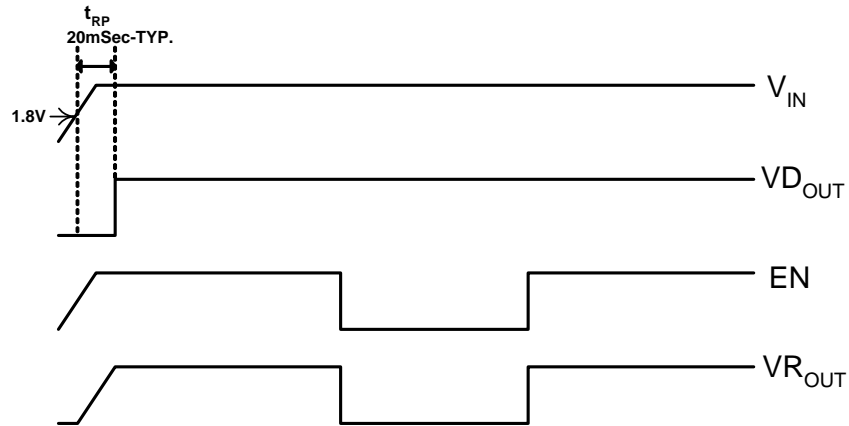

Application Note

Input Capacitor

A 1 μ F ceramic capacitor is recommended to connect between IN and GND pins to decouple input power supply glitch and noise. The amount of the capacitance may be increased without limit. A lower ESR (Equivalent Series Resistance) capacitor allows the use of less capacitance, while higher ESR type requires more capacitance. This input capacitor must be located as close as possible to the device to assure input stability and less noise. For PCB layout, a wide copper trace is required for both IN and GND.

Output Capacitor

The output capacitor is required to stabilize and help the transient response of the LDO. The AP7217 is designed to have excellent transient response for most applications with a small amount of output capacitance. The AP7217 is stable with any small ceramic output capacitors of 1.0 μ F or higher value, and the temperature coefficients of X7R or X5R type. Additional capacitance helps to reduce undershoot and overshoot during transient. For PCB layout, the output capacitor must be placed as close as possible to OUT and GND pins, and keep the leads as short as possible.

ENABLE/SHUTDOWN Operation

The AP7217 is turned on by setting the EN pin high, and is turned off by pulling it low. If this feature is not used, the EN pin should be tied to IN pin to keep the regulator output on at all time. To ensure proper operation, the signal source used to drive the EN pin must be able to swing above and below the specified turn-on/off voltage thresholds listed in the Electrical Characteristics section under V_{IL} and V_{IH} .

	VR_{OUT}	VD_{OUT}
EN=0	0V	ϕ
EN=1	3.3V	ϕ

Current Limit Protection

When output current at OUT pin is higher than current limit threshold, the current limit protection will be triggered and clamp the output current to approximately 600mA to prevent over-current and to protect the regulator from damage due to overheating.

Short circuit protection

When VR_{OUT} pin is shorted to GND or VR_{OUT} voltage is less than 200mV, short circuit protection will be triggered and clamp the output current to approximately 50mA.

VD_{OUT} (reset output)

---Open-Drain Active-Low reset output---

In general, VD_{OUT} is pulled up by a resistor (100Kohm) to V_{IN} . The AP7217 microprocess (uP) supervisory circuitry asserts a guaranteed logic-low reset during power-up and power-down. Reset is asserted asserts when V_{IN} is below the reset threshold and remain asserted for at least t_{RP} after V_{IN} rises above the reset threshold.

As long as V_{IN} is lower than the reset threshold, VD_{OUT} remains at logic "0". When V_{IN} become higher than V_{TH} , a logic "1" is asserted after a time delay defined by t_{RP} .

Marking Information

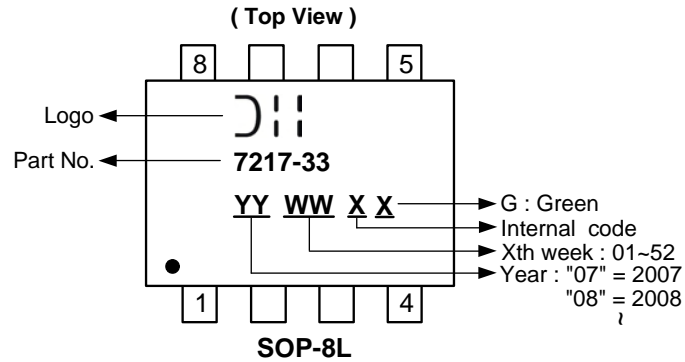

Package Information (All Dimensions in mm)

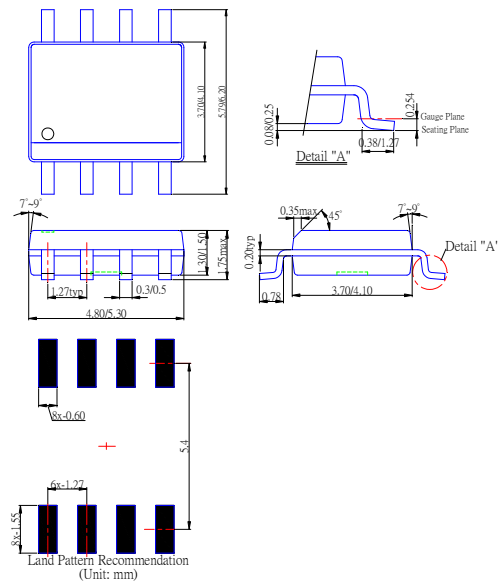

IMPORTANT NOTICE

Diodes Incorporated and its subsidiaries reserve the right to make modifications, enhancements, improvements, corrections or other changes without further notice to any product herein. Diodes Incorporated does not assume any liability arising out of the application or use of any product described herein; neither does it convey any license under its patent rights, nor the rights of others. The user of products in such applications shall assume all risks of such use and will agree to hold Diodes Incorporated and all the companies whose products are represented on our website, harmless against all damages.

LIFE SUPPORT

Diodes Incorporated products are not authorized for use as critical components in life support devices or systems without the expressed written approval of the President of Diodes Incorporated.