

**Features**

- Very Low Dropout Voltage
- Low Current Consumption: Typ. 40µA
- Output Voltage: 1.25V
- Guaranteed 600mA (min) Output
- Input Range up to 5.5V
- Current Limiting
- Stability with Low ESR Capacitors
- Thermal shutdown Protection
- Low Temperature Coefficient
- SOP-8L-EP: Available in "Green" Molding Compound (No Br, Sb)
- Lead Free Finish / RoHS Compliant (Note 1)

**General Description**

The AP7217C low-dropout linear regulator operates from a 2.5V to 5.5V supply and delivers a guaranteed 600mA (min) continuous load current.

The space-saving SOP-8L-EP package is suitable for "pocket" and hand-held applications.

**Applications**

- CD and MP3 Players
- Cellular and PCS Phones
- Digital Still Camera
- Hand-Held Computers

**Ordering Information**

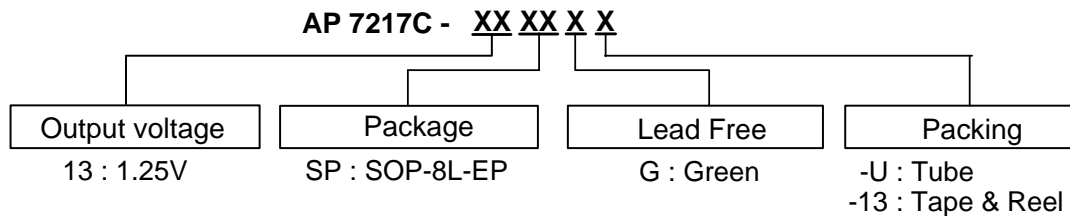

Device	Package Code	Packaging (Note 2)	Tube		13" Tape and Reel	
			Quantity	Part Number Suffix	Quantity	Part Number Suffix
AP7217C-XXSP	SP	SOP-8L-EP	100	-U	2500/Tape & Reel	-13

Notes: 1. EU Directive **2002/95/EC** (RoHS). All applicable RoHS exemptions applied, see *EU Directive 2002/95/EC Annex Notes*.  
 2. Pad layout as shown on Diodes Inc. suggested pad layout document AP02001, which can be found on our website at <http://www.diodes.com/datasheets/ap02001.pdf>.

## Pin Assignments

(1) SOP-8L-EP

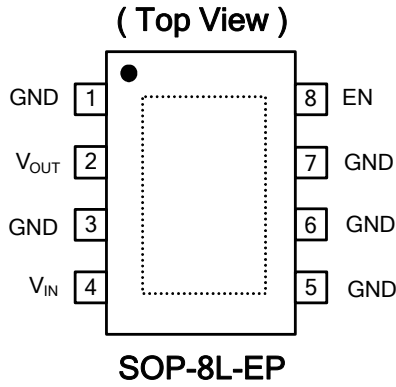

## Pin Descriptions

Pin Name	Pin No.	Function
GND	1, 3, 5, 6, 7	Ground
V <sub>OUT</sub>	2	Voltage Output
V <sub>IN</sub>	4	Supply Voltage
EN	8	High Enable

**Block Diagram**

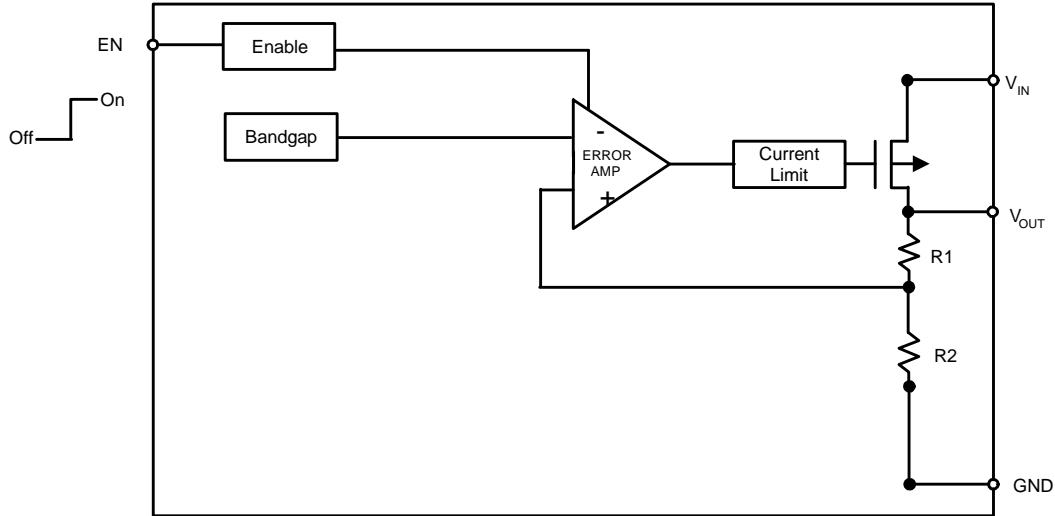

**Absolute Maximum Ratings**

Symbol	Parameter	Rating	Unit	
ESD HBM	Human Body Model ESD Protection	3.5	KV	
ESD MM	Machine Model ESD Protection	500	V	
$V_{IN}$	Input Voltage	+6	V	
$I_{OUT}$	Output Current	$P_D / (V_{IN} - V_O)$	mA	
$P_D$	Power Dissipation	SOP-8L-EP	1650	mW
$T_J$	Operating Junction Temperature Range	-40 to +125	°C	

**Recommended Operating Conditions**

Symbol	Parameter	Min	Max	Unit
$V_{IN}$	Input Voltage	2.5	5.5	V
$I_{OUT}$	Output Current	0	600	mA
$T_A$	Operating Ambient Temperature	-40	85	°C

**Electrical Characteristics**

(T<sub>A</sub> = 25°C, C<sub>IN</sub> = 1µF, C<sub>OUT</sub> = 1µF, V<sub>EN</sub> = V<sub>IN</sub>, unless otherwise noted)

Symbol	Parameter	Test Conditions	Min	Typ.	Max	Unit
I <sub>Q</sub>	Quiescent Current	I <sub>O</sub> = 0mA	-	40	60	µA
I <sub>STB</sub>	Standby Current	V <sub>EN</sub> = Off V <sub>IN</sub> = 5.0V		2	5	µA
V <sub>OUT</sub>	Output Voltage Accuracy	I <sub>O</sub> = 30mA, V <sub>IN</sub> = 5V	1.225	1.25	1.275	V
	V <sub>OUT</sub> Temperature Coefficient	-40°C to 85°C, I <sub>OUT</sub> = 30mA		±100		ppm / °C
V <sub>DROPOUT</sub>	Dropout Voltage	I <sub>OUT</sub> = 100mA, V <sub>OUT</sub> = 1.25V		1250		mV
		I <sub>OUT</sub> = 600mA, V <sub>OUT</sub> = 1.25V		2000		
I <sub>OUT</sub>	Maximum Output Current	V <sub>IN</sub> = 5.3V	600			mA
I <sub>LIMIT</sub>	Current Limit	V <sub>IN</sub> = 5.3V		750		mA
I <sub>SHORT</sub>	Short Circuit Current	V <sub>IN</sub> = 5.3V		70		mA
ΔV <sub>LINE</sub> /ΔV <sub>IN</sub> /V <sub>OUT</sub>	Line Regulation	4.3V ≤ V <sub>IN</sub> ≤ 5.5V; I <sub>OUT</sub> = 30mA		0.01	±0.2	%/V
ΔV <sub>OUT</sub>	Load Regulation	1mA ≤ I <sub>OUT</sub> ≤ 100mA, V <sub>IN</sub> = 5.3V		10	20	mV
PSRR	Power Supply Rejection	V <sub>IN</sub> = 4.3V + 0.5Vp-pAC, I <sub>OUT</sub> = 50mA, F = 1KHz		55		dB
V <sub>EH</sub>	EN Input Threshold	Output ON	1.6			V
V <sub>EL</sub>		Output OFF			0.25	V
I <sub>EN</sub>	Enable Pin Current		-0.1		0.1	µA
θ <sub>JA</sub>	Thermal Resistance Junction-to-Ambient	SOP-8L-EP (Note 3)		82		°C/W
θ <sub>JC</sub>	Thermal Resistance Junction-to-Case	SOP-8L-EP (Note 3)		12		°C/W

Notes: 3. Test condition for SOP-8L-EP: Device mounted on 2oz copper, minimum recommended pad layout on top & bottom layer with thermal vias, double sided FR-4 PCB.

**Typical Application**

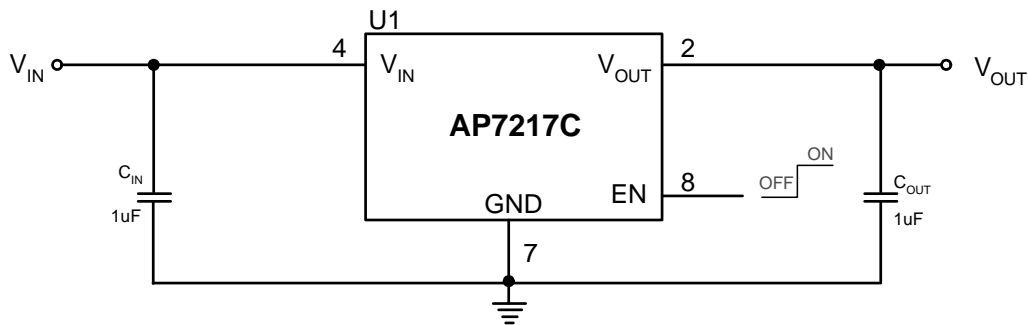

**Typical Performance Characteristics**

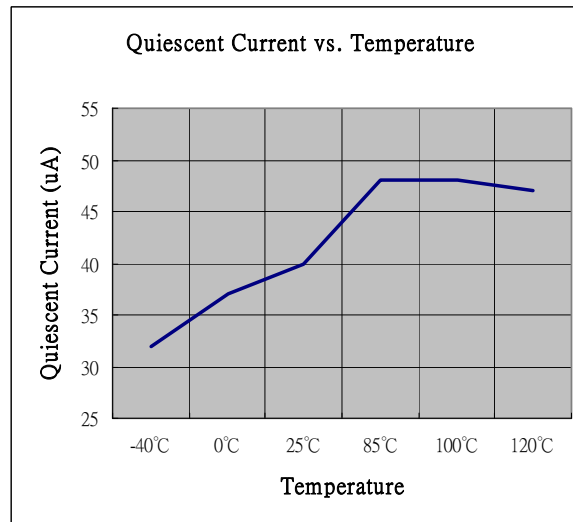
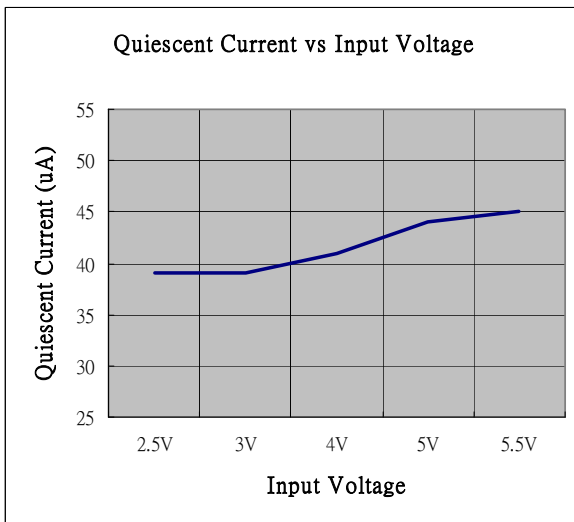
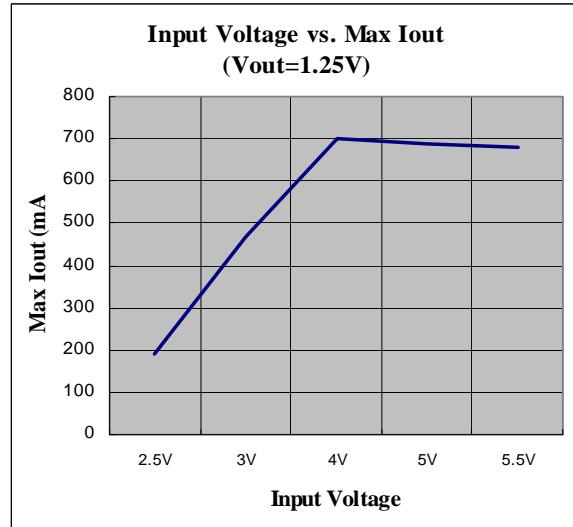
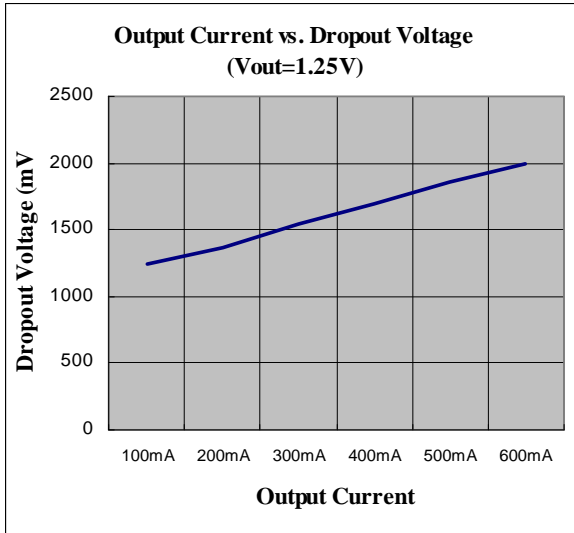

**Typical Performance Characteristics (Continued)**

**Load Transient Response**  
( $V_{OUT} = 1.25V$ )

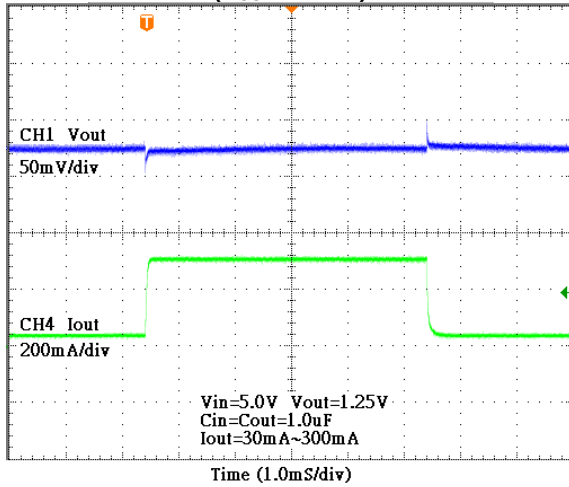

**Load Transient Response**  
( $V_{OUT} = 1.25V$ )

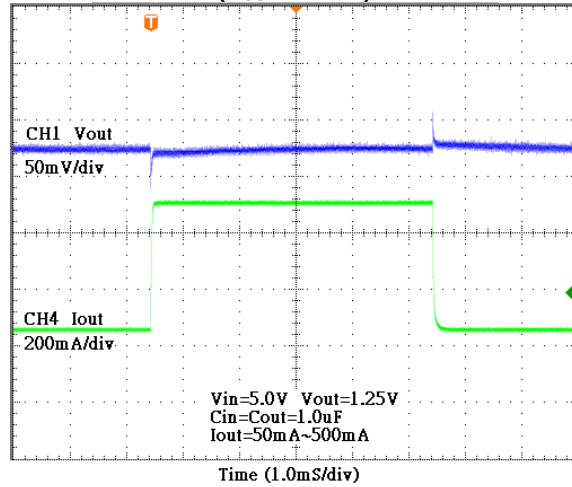

## Application Note

### Input Capacitor

A 1 $\mu$ F ceramic capacitor is recommended to connect between IN and GND pins to decouple input power supply glitch and noise. The amount of the capacitance may be increased without limit. A lower ESR (Equivalent Series Resistance) capacitor allows the use of less capacitance, while higher ESR type requires more capacitance. This input capacitor must be located as close as possible to the device to assure input stability and less noise. For PCB layout, a wide copper trace is required for both IN and GND.

### Output Capacitor

The output capacitor is required to stabilize and help the transient response of the LDO. The AP7217C is designed to have excellent transient response for most applications with a small amount of output capacitance. The AP7217C is stable with any small ceramic output capacitors of 1.0 $\mu$ F or higher value, and the temperature coefficients of X7R or X5R type. Additional capacitance helps to reduce undershoot and overshoot during transient. For PCB layout, the output capacitor must be placed as close as possible to OUT and GND pins, and keep the leads as short as possible.

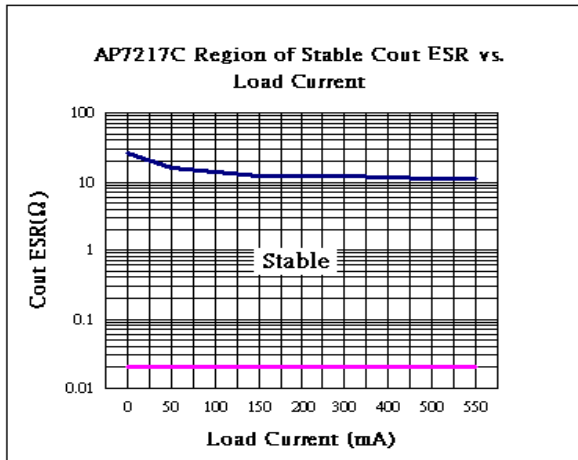

### ENABLE/SHUTDOWN Operation

The AP7217C (SOP-8L-EP) is turned on by setting the EN pin high, and is turned off by pulling it low. If this feature is not used, the EN pin should be tied to IN pin to keep the regulator output on at all time. To ensure proper operation, the signal source used to drive the EN pin must be able to swing above and below the specified turn-on/off voltage thresholds listed in the Electrical Characteristics section under  $V_{IL}$  and  $V_{IH}$ .

### Thermal Considerations

Thermal Shutdown Protection limits power dissipation in AP7217C. When the operation junction temperature exceeds 140°C, the Over Temperature Protection circuit starts the thermal shutdown function and turns the pass element off. The pass element turn on again after the junction temperature cools by 30°C. For continuous operation, do not exceed absolute maximum operation junction temperature 125°C. The power dissipation definition in device is:

$$P_D = (V_{IN} - V_{OUT}) \times I_{OUT} + V_{IN} \times I_Q$$

The maximum power dissipation depends on the thermal resistance of IC package, PCB layout, the rate of surroundings airflow and temperature difference between junctions to ambient. The maximum power dissipation can be calculated by following formula:

$$P_{D(MAX)} = (T_{J(MAX)} - T_A) / \theta_{JA}$$

Where  $T_{J(MAX)}$  is the maximum operation junction temperature 125°C,  $T_A$  is the ambient temperature and the  $\theta_{JA}$  is the junction to ambient thermal resistance.

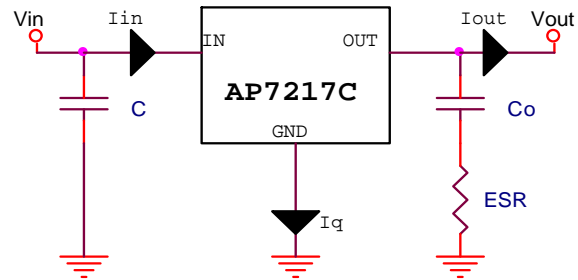

### Current Limit Protection

When output current at OUT pin is higher than current limit threshold, the current limit protection will be triggered and clamp the output current to approximately 750mA to prevent over-current and to protect the regulator from damage due to overheating.

### Short circuit protection

When  $V_{OUT}$  pin is shorted to GND or  $V_{OUT}$  voltage is less than 200mV, short circuit protection will be triggered and clamp the output current to approximately 70mA.

**Marking Information**

(1) SOP-8L-EP

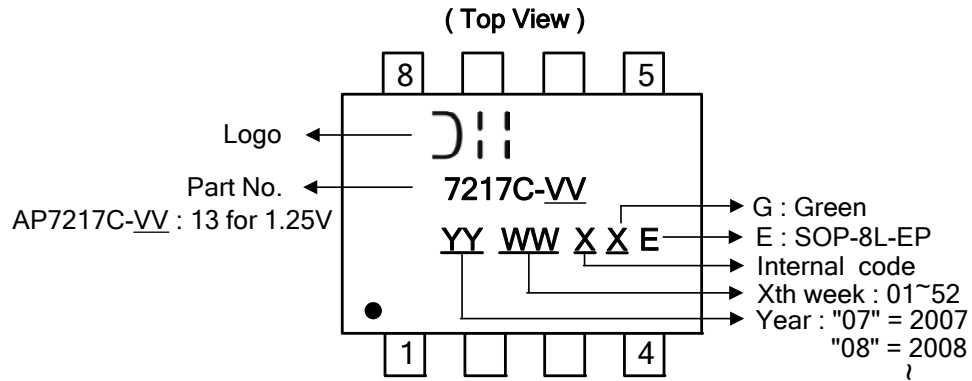

**Package Information (All Dimensions in mm)**

(1) Package Type: SOP-8L-EP

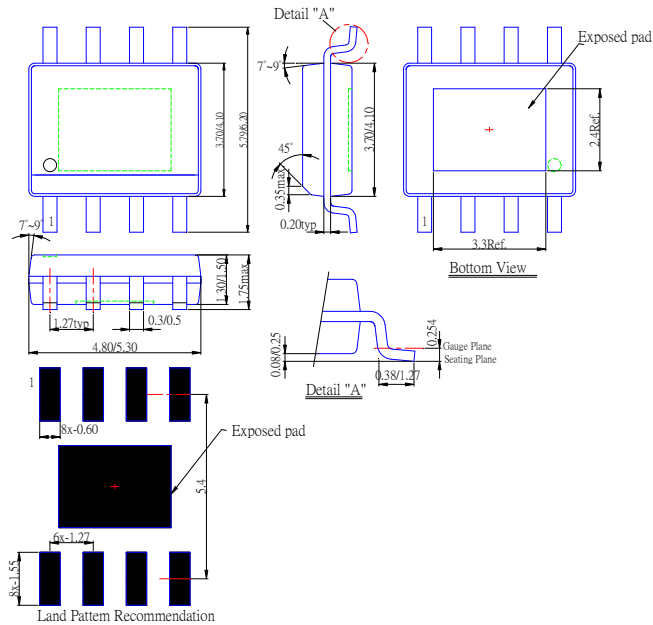



**IMPORTANT NOTICE**

Diodes Incorporated and its subsidiaries reserve the right to make modifications, enhancements, improvements, corrections or other changes without further notice to any product herein. Diodes Incorporated does not assume any liability arising out of the application or use of any product described herein; neither does it convey any license under its patent rights, nor the rights of others. The user of products in such applications shall assume all risks of such use and will agree to hold Diodes Incorporated and all the companies whose products are represented on our website, harmless against all damages.

**LIFE SUPPORT**

Diodes Incorporated products are not authorized for use as critical components in life support devices or systems without the expressed written approval of the President of Diodes Incorporated.