

**DUAL OPAMP AND VOLTAGE REFERENCE****AP4301****General Description**

The AP4301 is a monolithic IC specifically designed to control the output current and voltage levels of switch mode battery chargers and power supplies.

The device contains two operational amplifiers and a precision shunt regulator. OPAMP 1 is designed for voltage control, whose non-inverting input internally connects to the output of the shunt regulator. OPAMP 2 is for current control with both inputs uncommitted. The IC offers the power converter designer a control solution that features increased precision with a corresponding reduction in system complexity and cost.

Features

- Input offset voltage: 0.5mV
- Supply current: 250 μ A per Op-Amp at 5.0V supply voltage
- Unity gain bandwidth: 1MHz
- Output voltage swing: 0 to ($V_{CC} - 1.5$)V
- Power supply range: 3 to 18V
- Fixed output voltage reference: 1.25V, 1.24V
- Voltage tolerance: 0.5%, 1%
- Sink current capability from 0.1 to 80mA
- Package types: DIP-8 and SOIC-8

Applications

- Battery charger
- Switch mode power supply

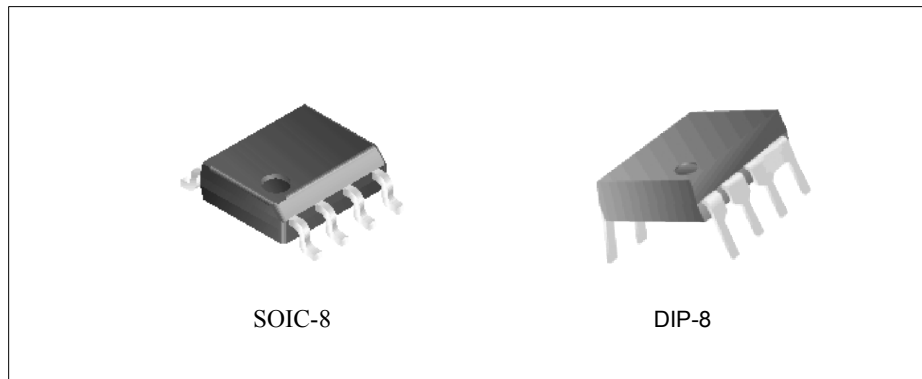

Figure 1. Package Types of AP4301



DUAL OPAMP AND VOLTAGE REFERENCE

AP4301

Pin Configuration

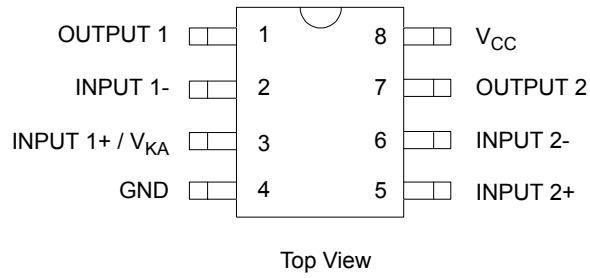

Figure 2. Pin configuration of AP4301

Functional Block Diagram

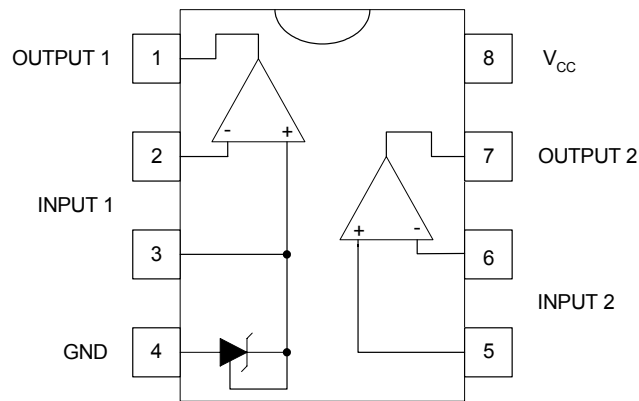

Figure 3. Functional Block Diagram of AP4301



DUAL OPAMP AND VOLTAGE REFERENCE

AP4301

Functional Block Diagram (Continued)

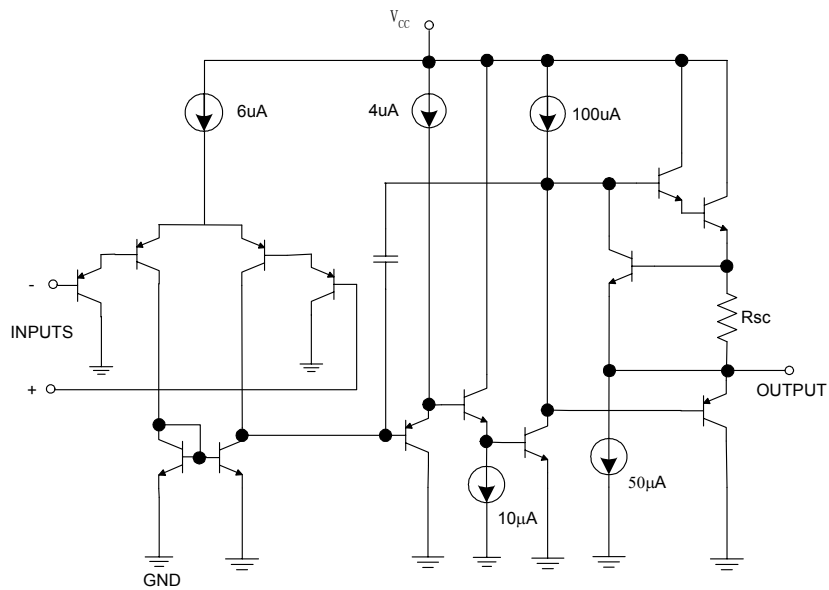

Figure 4. OPAMP Functional Block Diagram (Each Amplifier)

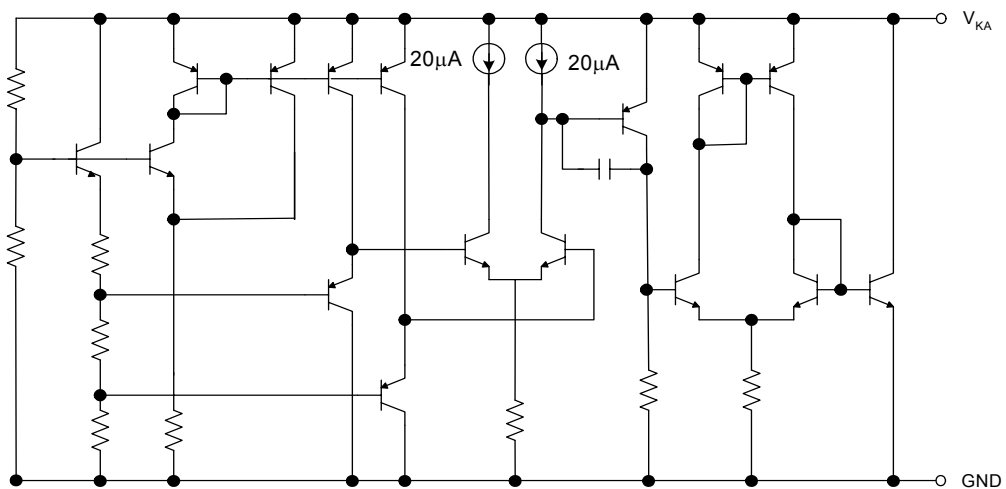

Figure 5. Voltage Reference Functional Block Diagram



DUAL OPAMP AND VOLTAGE REFERENCE

AP4301

Ordering Information

Package	Reference Voltage	Voltage Tolerance	Temperature Range	Part Number	Marking ID	Packing Type
DIP-8	1.25V	0.5%	-40 to 85°C	AP4301AP-C	AP4301AP-C	Tube
		1%		AP4301BP-C	AP4301BP-C	
	1.24V	0.5%		AP4301AP-D	AP4301AP-D	
		1%		AP4301BP-D	AP4301BP-D	
SOIC-8	1.25V	0.5%		AP4301AM-C	AP4301AM-C	Tube/Reel
		1%		AP4301BM-C	AP4301BM-C	
	1.24V	0.5%		AP4301AM-D	AP4301AM-D	
		1%		AP4301BM-D	AP4301BM-D	

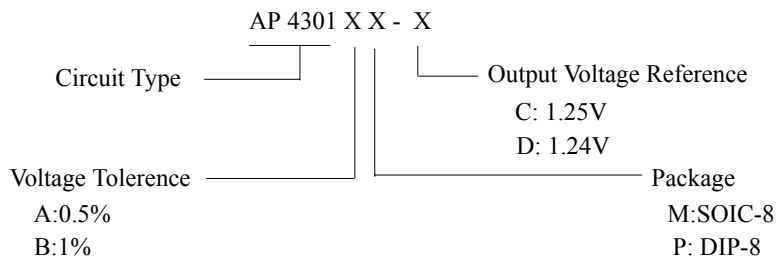

**DUAL OPAMP AND VOLTAGE REFERENCE****AP4301****Absolute Maximum Ratings**

Parameter	Symbol	Value	Unit	
Power Supply Voltage (V_{CC} to GND)	V_{CC}	20	V	
OPAMP 1 and 2 Input Voltage Range (Pins 2, 5, 6)	V_{IN}	- 0.3 to V_{CC} - 0.3	V	
OPAMP 2 Input Differential Voltage (Pins 5, 6)	V_{ID}	20	V	
Voltage Reference Cathode Current (Pin 3)	I_K	100	mA	
Power Dissipation	P_D	DIP-8	800	mW
		SOIC-8	500	
Storage Temperature Range	T_{STG}	-65 to 150	°C	
ESD Protection Voltage (Machine Model)	-	≥ 200	V	

Note: Stresses greater than those listed under "Absolute Maximum Ratings " may cause permanent damage to the device. These are stress ratings only, and functional operation of the device at these or any other conditions beyond those indicated under "Recommended Operation Ratings " is not implied. Exposure to "Absolute Maximum Ratings " for extended periods may affect device reliability.

Recommended Operating Ratings

Parameter	Min	Max	Unit
Supply Voltage	3	18	V
Ambient Temperature	-40	85	°C



DUAL OPAMP AND VOLTAGE REFERENCE

AP4301

Electrical Characteristics

Operating Conditions: $V_{CC} = +5V$, $T_A = 25^\circ C$ unless otherwise specified.

Parameter	Conditions	Min	Typ	Max	Unit	
Total Supply Current, excluding Current in Voltage Reference	$V_{CC} = 5V$, no load, $-40^\circ C \leq T_A \leq 85^\circ C$		0.5	0.8	mA	
	$V_{CC} = 18V$, no load, $-40^\circ C \leq T_A \leq 85^\circ C$		0.6	1.2		
Voltage Reference Section						
Reference Voltage for AP4301-C	$I_K = 10mA$ $T_A = 25^\circ C$	0.5% tolerance	1.244	1.250	1.256	V
		1% tolerance	1.237		1.263	
Reference Voltage for AP4301-D	$I_K = 10mA$ $T_A = 25^\circ C$	0.5% tolerance	1.234	1.240	1.246	V
		1% tolerance	1.227		1.252	
Reference Voltage Deviation Over Full Temperature Range	$I_K = 10mA$, $T_A = -40$ to $85^\circ C$		5	17	mV	
Minimum Cathode Current for Regulation			0.2	1	mA	
Dynamic Impedance	$I_K = 1.0$ to $80mA$, $f < 1kHz$		0.2	0.5	Ω	
OPAMP 1 Section ($V_{CC} = 5V$, $V_O = 1.4V$, $T_A = 25^\circ C$, unless otherwise noted)						
Input Offset Voltage	$T_A = 25^\circ C$ $T_A = -40$ to $85^\circ C$		0.5	3	mV	
				5		
Input Offset Voltage Temperature Drift	$T_A = -40$ to $85^\circ C$			7	$\mu V/^\circ C$	
Input Bias Current (Inverting Input Only)	$T_A = 25^\circ C$		20	150	nA	
Large Signal Voltage Gain	$V_{CC} = 15V$, $R_L = 2k\Omega$, $V_O = 1.4$ to $11.4V$	85	100		dB	
Power Supply Rejection Ratio	$V_{CC} = 5$ to $18V$	70	90		dB	
Output Current	Source	$V_{CC} = 15V$, $V_{ID} = 1V$, $V_O = 2V$	20	40	mA	
	Sink	$V_{CC} = 15V$, $V_{ID} = -1V$, $V_O = 2V$	10	20	mA	
Output Voltage Swing (High)	$V_{CC} = 18V$, $R_L = 10k\Omega$, $V_{ID} = 1V$	16	16.5		V	
Output Voltage Swing (Low)	$V_{CC} = 18V$, $R_L = 10k\Omega$, $V_{ID} = -1V$		17	100	mV	
Slew Rate	$V_{CC} = 18V$, $R_L = 2k\Omega$, $A_V = 1$, $V_{IN} = 0.5$ to $2V$, $C_L = 100pF$	0.2	0.5		V/ μs	
Gain Bandwidth Product	$V_{CC} = 18V$, $R_L = 2k\Omega$, $C_L = 100pF$, $V_{IN} = 10mV$, $f = 100kHz$	0.5	1		MHz	



DUAL OPAMP AND VOLTAGE REFERENCE

AP4301

Electrical Characteristics (Continued)

Operating Conditions: $V_{CC} = +5V$, $T_A = 25^\circ C$ unless otherwise specified.

Parameter	Conditions	Min	Typ	Max	Unit
OPAMP2 Section ($V_{CC} = 5V$, $V_O = 1.4V$, $T_A = 25^\circ C$, unless otherwise noted)					
Input Offset Voltage	$T_A = 25^\circ C$		0.5	3	mV
	$T_A = -40$ to $85^\circ C$			5	
Input Offset Voltage Temperature Drift	$T_A = -40$ to $85^\circ C$		7		$\mu V/^\circ C$
Input Offset Current	$T_A = 25^\circ C$		2	30	nA
Input Bias Current	$T_A = 25^\circ C$		20	150	nA
Input Voltage Range	$V_{CC} = 0$ to $18V$	0		$V_{CC} - 1.5$	V
Common Mode Rejection Ratio	$T_A = 25^\circ C$, $V_{CM} = 0$ to $3.5V$	70	85		dB
Large Signal Voltage Gain	$V_{CC} = 15V$, $R_L = 2k\Omega$, $V_O = 1.4$ to $11.4V$	85	100		dB
Power Supply Rejection Ratio	$V_{CC} = 5$ to $18V$	70	90		dB
Output Current	Source $V_{CC} = 15V$, $V_{ID} = 1V$, $V_O = 2V$	20	40		mA
	Sink $V_{CC} = 15V$, $V_{ID} = -1V$, $V_O = 2V$	10	20		mA
Output Voltage Swing (High)	$V_{CC} = 18$, $R_L = 10k\Omega$, $V_{ID} = 1V$	16	16.5		V
Output Voltage SWing (Low)	$V_{CC} = 18$, $R_L = 10k\Omega$, $V_{ID} = -1V$		17	100	mV
Slew Rate	$V_{CC} = 18V$, $R_L = 2k\Omega$, $A_V = 1$, $V_{IN} = 0.5$ to $2V$, $C_L = 100pF$	0.2	0.5		$V/\mu s$
Gain Bandwidth Product	$V_{CC} = 18V$, $R_L = 2k\Omega$, $C_L = 100pF$, $V_{IN} = 10mV$, $f=100kHz$	0.5	1		MHz



Typical Characteristics

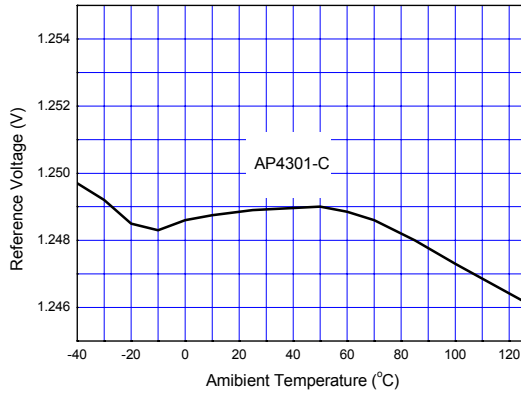

Figure 6. Reference Voltage vs. Ambient Temperature

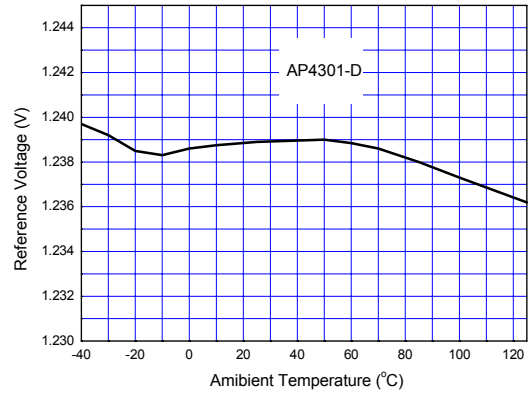

Figure 7. Reference Voltage vs. Ambient Temperature

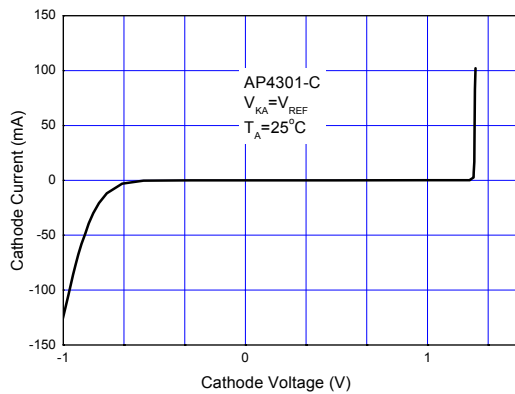

Figure 8. Cathode Current vs. Cathode Voltage

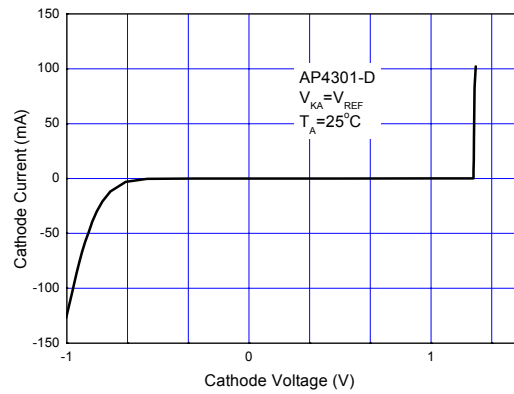

Figure 9. Cathode Current vs. Cathode Voltage



Typical Characteristics (Continued)

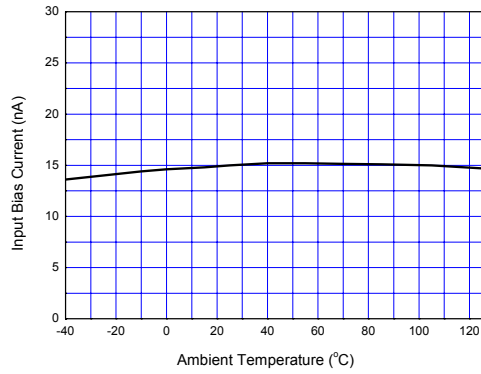

Figure 10. Input Bias Current vs. Ambient Temperature

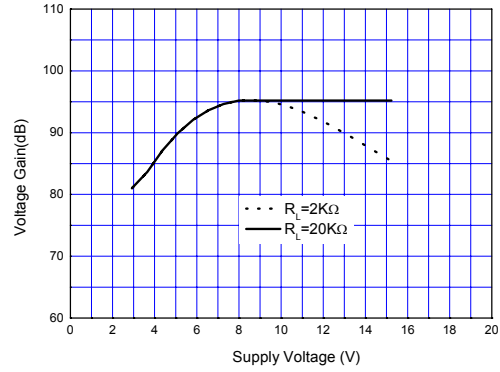

Figure 11. Operational Amplifier Voltage Gain



DUAL OPAMP AND VOLTAGE REFERENCE

AP4301

Typical Application

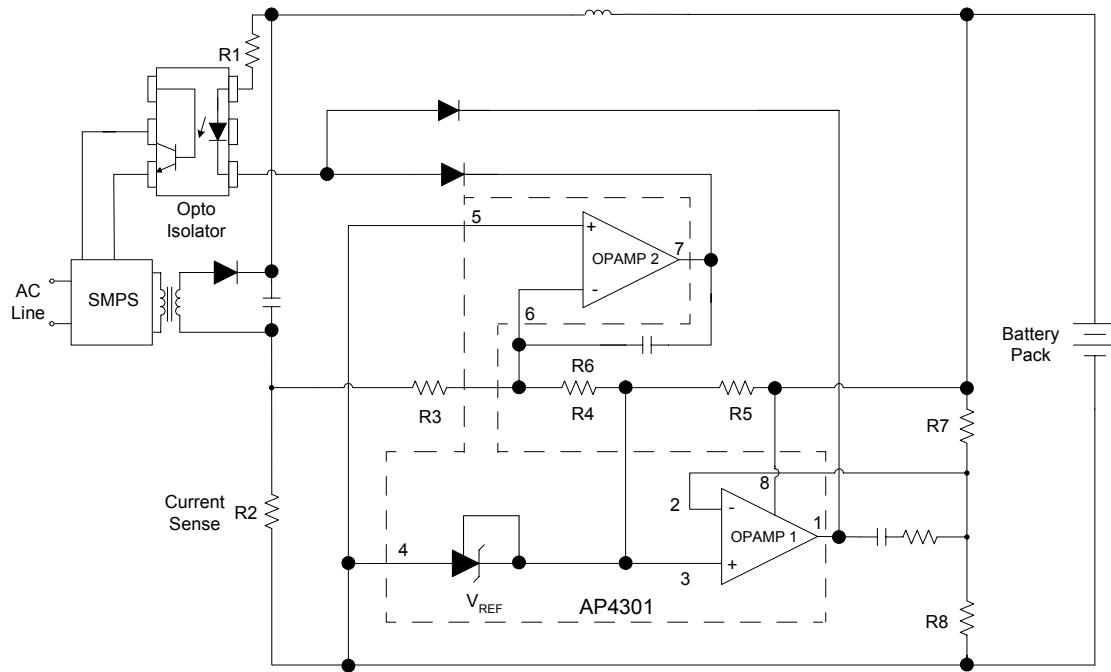

Figure 12. Typical Application of AP4301



DUAL OPAMP AND VOLTAGE REFERENCE

AP4301

Mechanical Dimensions

DIP - 8

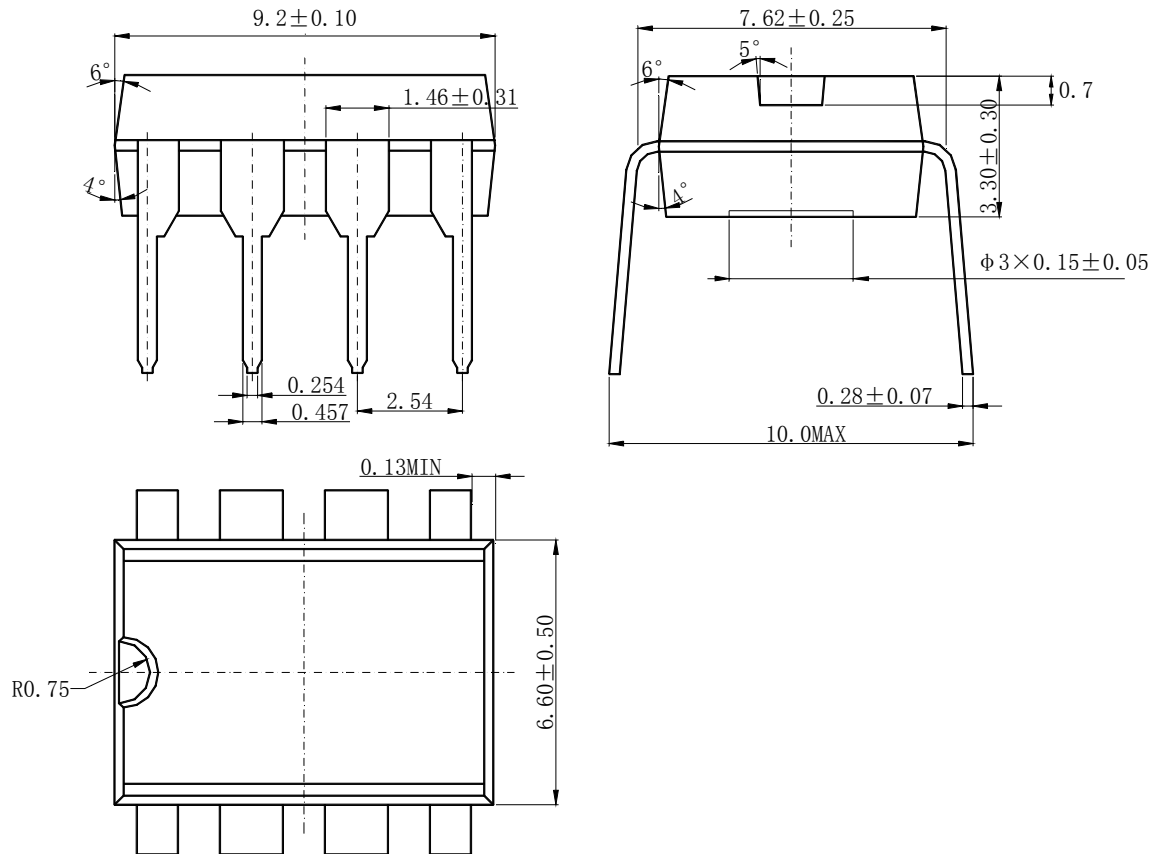



Mechanical Dimensions (Continued)

SOIC - 8

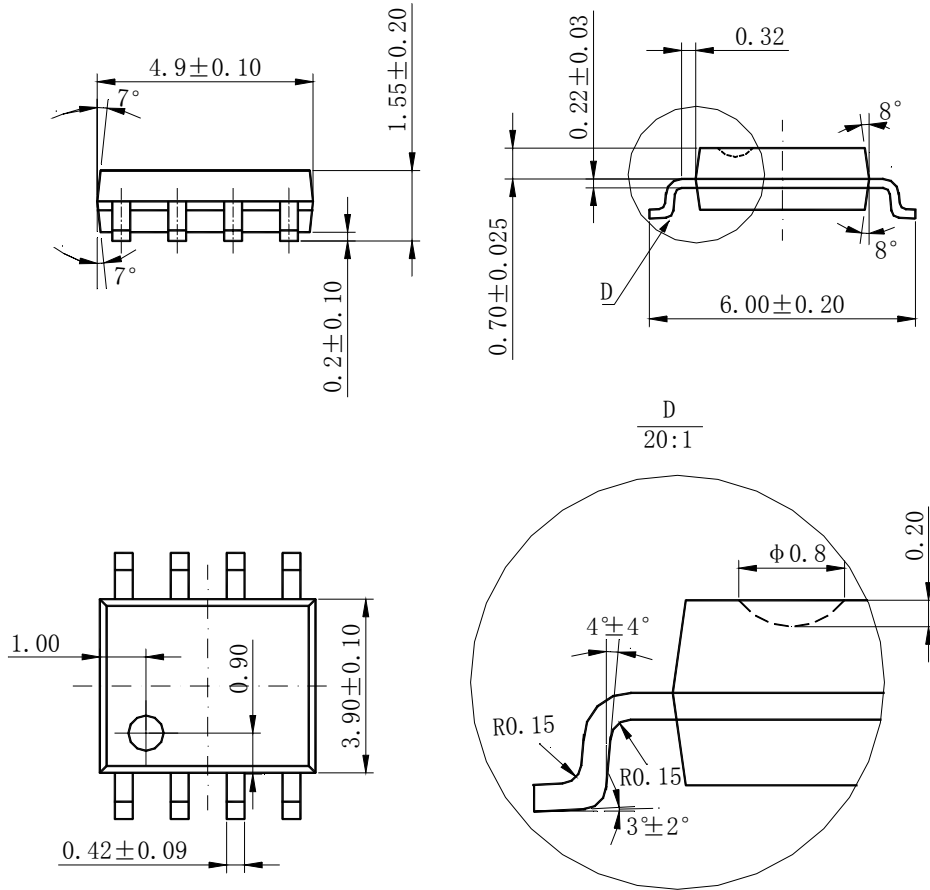



<http://www.aacmicro.com>

USA: 1510 Montague Expressway, San Jose, CA 95131, USA

Tel: 408-433-9888, Fax: 408-432-9888

China: 8th Floor, Zone B, 900 Yi Shan Road, Shanghai 200233, China

Tel: 86-21-6495-9539, Fax: 86-21-6485-9673

Taiwan: Room 2210, 22nd Fl, 333, Keelung Road, Secretary 1, Taipei, Taiwan

Tel: 886-2-2564-3699, Fax: 886-2-2564-3770

IMPORTANT NOTICE

Advanced Analog Circuits Corporation reserves the right to make changes to its products or specifications at any time, without notice, to improve design or performance and to supply the best possible product. Advanced Analog Circuits does not assume any responsibility for use of any circuitry described other than the circuitry embodied in Advanced Analog Circuits' products. The company makes no representation that circuitry described herein is free from patent infringement or other rights of Advanced Analog Circuits Corporation.