

Features

- 1.4V Maximum Dropout at Full Load Current
- Fast Transient Response
- Output Current Limiting
- Built-in Thermal Shutdown
- Good Noise Rejection
- 3-Terminal Adjustable or Fixed 1.5V, 1.8V, 2.5V, 3.3V, 5.0V
- SOT223-3L, TO252-3L, SOT89-3L, TO263-3L and TO220-3L Packages
- SOT223-3L and TO252-3L: Available in "Green" Molding Compound (No Br, Sb)
- Lead Free Finish/RoHS Compliant (Note 2)

General Description

AP1117 is a low dropout positive adjustable or fixed-mode regulator with 1A output current capability. The product is voltage specifically designed to provide well-regulated supply for low IC applications such as high-speed bus termination and low current 3.3V logic supply. AP1117 is also well suited for other applications such as VGA cards. AP1117 is guaranteed to have lower than 1.4V dropout at full load current making it ideal to provide well-regulated outputs of 1.25 to 5.0 with 6.4V to 18V input supply. AP1117 is available in both commercial and industrial temperature grade.

Applications

- PC Peripheral
- Communication

Ordering Information

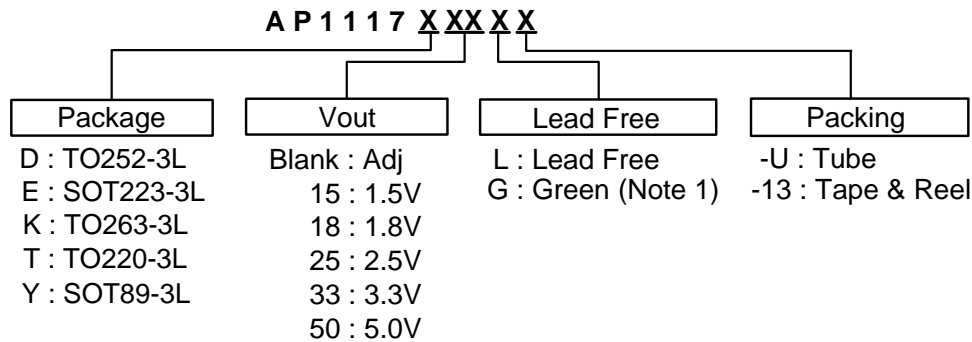

Device	Package Code	Packaging (Note 3)	Tube		13" Tape and Reel	
			Quantity	Part Number Suffix	Quantity	Part Number Suffix
AP1117DXXL-U	D	TO252-3L	80	-U	NA	NA
AP1117DXXL-13	D	TO252-3L	NA	NA	2500/Tape & Reel	-13
AP1117DXXG-U	D	TO252-3L	80	-U	NA	NA
AP1117DXXG-13	D	TO252-3L	NA	NA	2500/Tape & Reel	-13
AP1117EXXL-U	E	SOT223-3L	75	-U	NA	NA
AP1117EXXL-13	E	SOT223-3L	NA	NA	2500/Tape & Reel	-13
AP1117EXXG-U	E	SOT223-3L	75	-U	NA	NA
AP1117EXXG-13	E	SOT223-3L	NA	NA	2500/Tape & Reel	-13
AP1117KXXL-U	K	TO263-3L	50	-U	NA	NA
AP1117KXXL-13	K	TO263-3L	NA	NA	800/Tape & Reel	-13
AP1117TXXL-U	T	TO220-3L	50	-U	NA	NA
AP1117YXXL-13	Y	SOT89-3L	NA	NA	2500/Tape & Reel	-13

Notes: 1. SOT223-3L and TO252-3L are available in "Green" products only.
 2. EU Directive 2002/95/EC (RoHS). All applicable RoHS exemptions applied, see *EU Directive 2002/95/EC Annex Notes*.
 3. Pad layout as shown on Diodes Inc. suggested pad layout document AP02001, which can be found on our website at <http://www.diodes.com/datasheets/ap02001.pdf>.

Pin Assignments

SOT89-3L

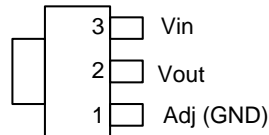

Tab is V_{out}

SOT223-3L

(Top View)

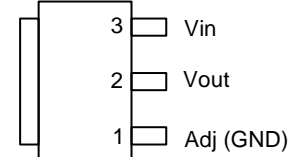

Tab is V_{out}

TO220-3L

FRONT VIEW

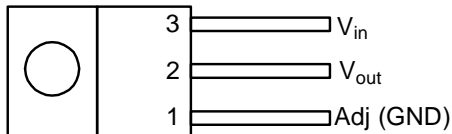

Tab is V_{out}

TO252-3L / TO263-3L

(Top View)

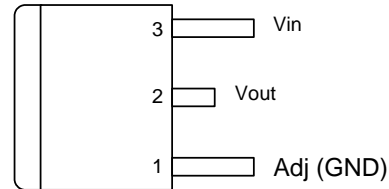

Tab is V_{out}

Pin Descriptions

NAME	I/O	PIN #	FUNCTION
Adj (GND)	I	1	A resistor divider from this pin to the V _{out} pin and ground sets the output voltage (Ground only for Fixed-Mode).
V _{out}	O	2	The output of the regulator. A minimum of 10uF capacitor (0.15Ω ≤ ESR ≤ 20Ω) must be connected from this pin to ground to insure stability.
V _{in}	I	3	The input pin of regulator. Typically a large storage capacitor (0.15Ω ≤ ESR ≤ 20Ω) is connected from this pin to ground to insure that the input voltage does not sag below the minimum dropout voltage during the load transient response. This pin must always be 1.3V higher than V _{out} in order for the device to regulate properly.

Block Diagram

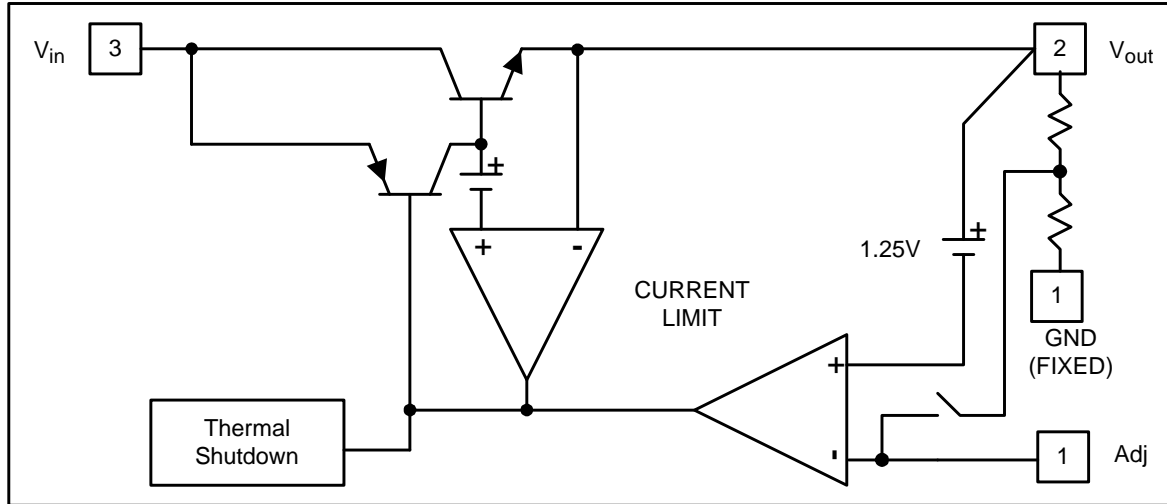

Absolute Maximum Ratings

Symbol	Parameter	Rating	Unit
V_{in}	DC Supply Voltage	-0.3 to 18	V
T_{OP}	Operating Junction Temperature Range (Commercial Grade)	0 to +125	$^{\circ}C$
T_{MJ}	Maximum Junction Temperature	150	$^{\circ}C$
P_D	Power Dissipation SOT89-3L SOT223-3L TO220-3L TO252-3L TO263-3L	Internally limited by maximum junction temperature of 150 $^{\circ}C$ (Note 4)	mW
T_{ST}	Storage Temperature	-65 to +150	$^{\circ}C$

Notes: 4. AP1117 contains an internal thermal limiting circuit that is designed to protect the regulator in the event that the maximum junction temperature exceeded. When activated, typically at 150 $^{\circ}C$, the regulator output switches off and then back on as the die cools.

Electrical Characteristics (Under Operating Conditions)

Parameter	Conditions	Min	Typ.	Max	Unit
Reference Voltage	AP1117-ADJ $T_A = 25^\circ\text{C}$, $(V_{IN-OUT}) = 1.5\text{V}$ $I_O = 10\text{mA}$	1.225	1.250	1.275	V
Output Voltage	AP1117-1.5 $I_{OUT} = 10\text{mA}$, $T_A = 25^\circ\text{C}$, $3\text{V} \leq V_{IN} \leq 12\text{V}$	1.470	1.500	1.530	V
	AP1117-1.8 $I_{OUT} = 10\text{mA}$, $T_A = 25^\circ\text{C}$, $3.3\text{V} \leq V_{IN} \leq 12\text{V}$	1.764	1.800	1.836	V
	AP1117-2.5 $I_{OUT} = 10\text{mA}$, $T_A = 25^\circ\text{C}$, $4\text{V} \leq V_{IN} \leq 12\text{V}$	2.450	2.500	2.550	V
	AP1117-3.3 $I_{OUT} = 10\text{mA}$, $T_A = 25^\circ\text{C}$, $4.8\text{V} \leq V_{IN} \leq 12\text{V}$	3.235	3.300	3.365	V
	AP1117-5.0 $I_{OUT} = 10\text{mA}$, $T_A = 25^\circ\text{C}$, $6.5\text{V} \leq V_{IN} \leq 12\text{V}$	4.900	5.000	5.100	V
Line Regulation	AP1117-XXX $I_O = 10\text{mA}$, $V_{OUT} + 1.5\text{V} < V_{IN} < 12\text{V}$, $T_A = 25^\circ\text{C}$			0.2	%
Load Regulation	AP1117-ADJ $V_{IN} = 3.3\text{V}$, $V_{adj} = 0$, $0\text{mA} < I_O < 1\text{A}$, $T_A = 25^\circ\text{C}$ (Note 5, 6)			1	%
	AP1117-1.5 $V_{IN} = 3\text{V}$, $0\text{mA} < I_O < 1\text{A}$, $T_A = 25^\circ\text{C}$ (Note 5, 6)		12	15	mV
	AP1117-1.8 $V_{IN} = 3.3\text{V}$, $0\text{mA} < I_O < 1\text{A}$, $T_A = 25^\circ\text{C}$ (Note 5, 6)		15	18	mV
	AP1117-2.5 $V_{IN} = 4\text{V}$, $0\text{mA} < I_O < 1\text{A}$, $T_A = 25^\circ\text{C}$ (Note 5, 6)		20	25	mV
	AP1117-3.3 $V_{IN} = 5\text{V}$, $0 \leq I_{OUT} \leq 1\text{A}$, $T_A = 25^\circ\text{C}$ (Note 5, 6)		26	33	mV
	AP1117-5.0 $V_{IN} = 8\text{V}$, $0 \leq I_{OUT} \leq 1\text{A}$, $T_A = 25^\circ\text{C}$ (Note 5, 6)		40	50	mV
Dropout Voltage ($V_{IN} - V_{OUT}$)	AP1117-ADJ/1.5/1.8 /2.5/3.3/5.0 $I_{OUT} = 1\text{A}$, $\Delta V_{OUT} = 0.1\% V_{OUT}$		1.3	1.4	V
Current Limit	AP1117-ADJ/1.5/1.8 /2.5/3.3/5.0 $(V_{IN} - V_{OUT}) = 5\text{V}$	1.1			A
Minimum Load Current (Note 7)	AP1117-XXX $0^\circ\text{C} \leq T_J \leq 125^\circ\text{C}$		5	10	mA
Thermal Regulation	$T_A = 25^\circ\text{C}$, 30ms pulse		0.008	0.04	%/W
Ripple Rejection	$F = 180\text{Hz}$, $C_{OUT} = 25\mu\text{F}$ Tantalum, $I_{OUT} = 1\text{A}$				
	AP1117-XXX $V_{IN} = V_{OUT} + 3\text{V}$		60	70	dB
Temperature Stability	$I_O = 10\text{mA}$		0.5		%
θ_{JA} Thermal Resistance Junction-to-Ambient	SOT223-3L: Control Circuitry/Power Transistor (Note 8)				
	TO252-3L: Control Circuitry/Power Transistor (Note 9)				
	SOT89-3L: Control Circuitry/Power Transistor (Note 10)				
	TO220-3L: Control Circuitry/Power Transistor (Note 11)				
	TO263-3L: Control Circuitry/Power Transistor (Note 12)				
θ_{JC} Thermal Resistance Junction-to-Case	SOT223-3L: Control Circuitry/Power Transistor (Note 8)				
	TO252-3L: Control Circuitry/Power Transistor (Note 9)				
	SOT89-3L: Control Circuitry/Power Transistor (Note 10)				
	TO220-3L: Control Circuitry/Power Transistor (Note 11)				
	TO263-3L: Control Circuitry/Power Transistor (Note 12)				

- Notes:
- See thermal regulation specifications for changes in output voltage due to heating effects. Line and load regulation are measured at a constant junction temperature by low duty cycle pulse testing. Load regulation is measured at the output lead = 1/18" from the package.
 - Line and load regulation are guaranteed up to the maximum power dissipation of 15W. Power dissipation is determined by the difference between input and output differential and the output current. Guaranteed maximum power dissipation will not be available over the full input/output range.
 - Quiescent current is defined as the minimum output current required in maintaining regulation. At 12V input/output differential the device is guaranteed to regulate if the output current is greater than 10mA.
 - Test condition for SOT223: $T_A = 27^\circ\text{C}$, no air flow, 2 oz copper, 5mmx5mm pad.
 - Test condition for TO252: $T_A = 27^\circ\text{C}$, no air flow, 2 oz copper, 5mmx5mm pad.
 - Test condition for SOT89-3L: no air flow, no heat sink.
 - Test condition for TO220-3L: with copper area of approximately 3in², 1 oz, no air flow.
 - Test condition for TO263-3L: no air flow, no heat sink.

Typical Performance Characteristics

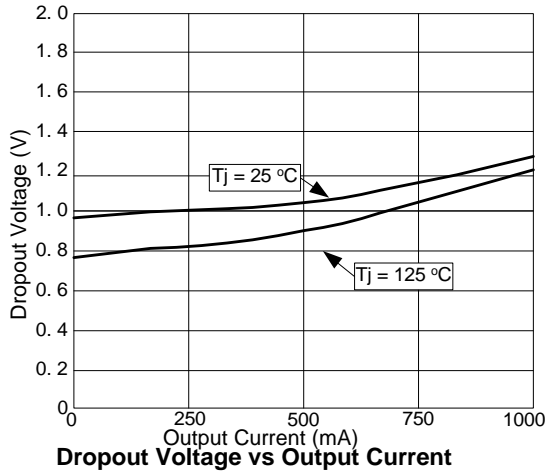

Dropout Voltage vs Output Current

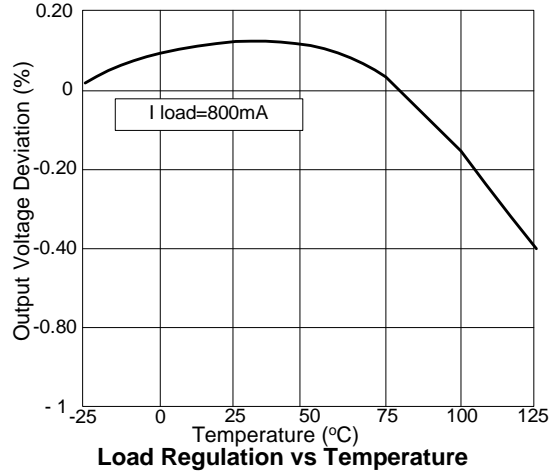

Load Regulation vs Temperature

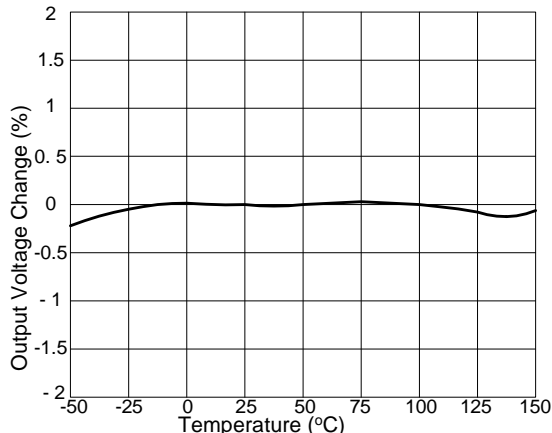

Percent Change in Output Voltage vs Temperature

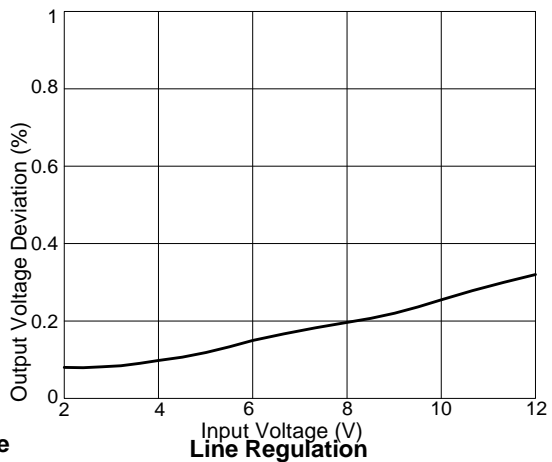

Line Regulation

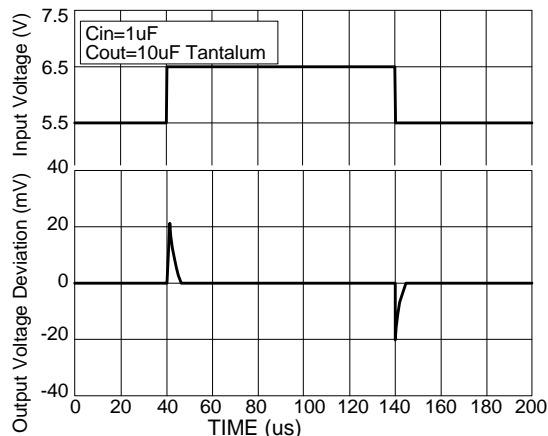

Line Transient Response

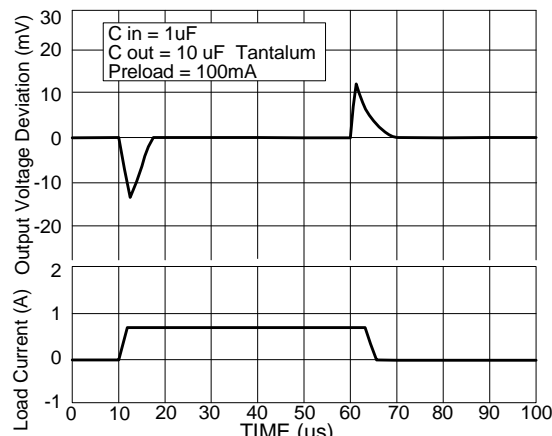

Load Transient Response

Typical Application Circuit

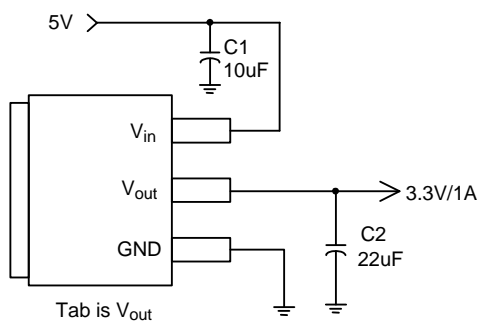

(5V/3.3V fixed output)

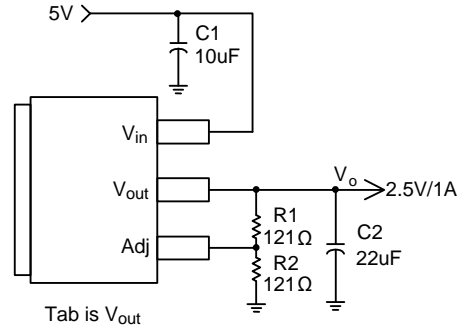

(5V/2.5V ADJ output)

Note: $V_o = V_{REF} * (1 + \frac{R_2}{R_1})$

Marking Information

(1) SOT223-3L

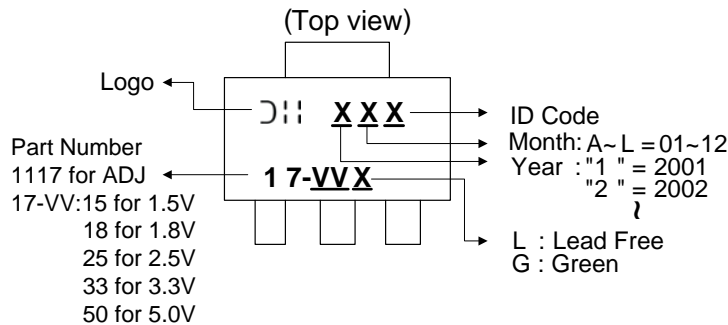

(2) TO252-3L

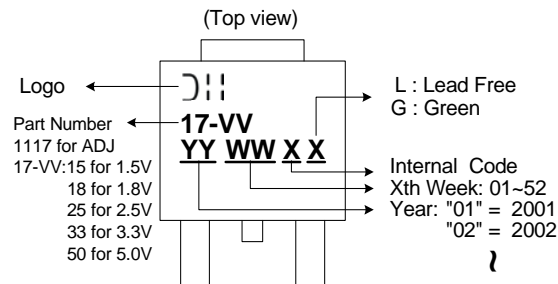

Marking Information (Continued)

(3) SOT89-3L

(Top View)

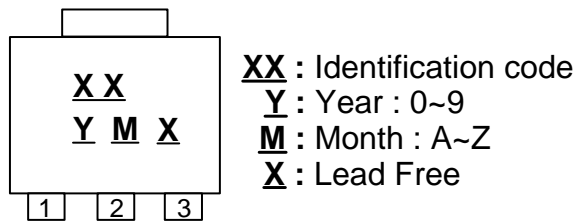

Marking Code Table

Identification Code	Output Version
DA	AP1117-ADJ
DB	AP1117-1.5V
DC	AP1117-1.8V
DD	AP1117-2.5V
DE	AP1117-3.3V
DF	AP1117-5.0V

(4) TO263-3L

(Top view)

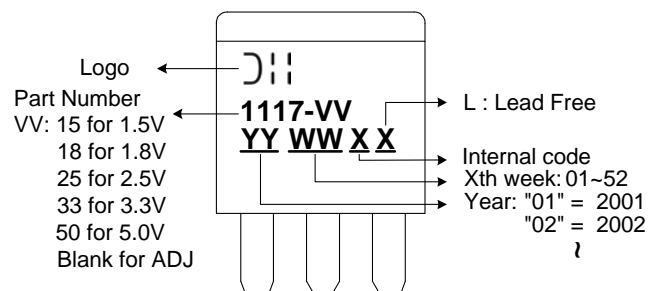

Marking Information (Continued)

(5) TO220-3L

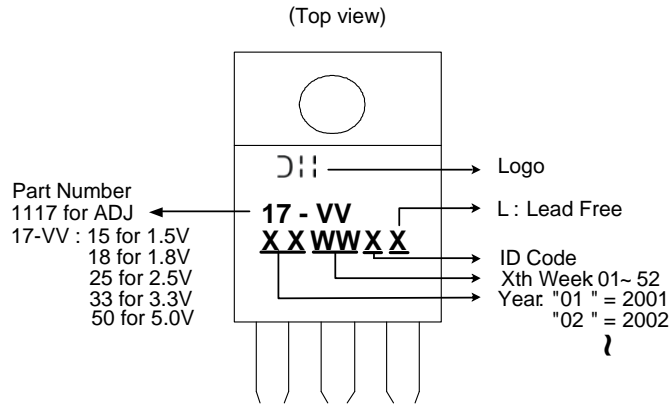

Package Information (All Dimensions in mm)

(1) SOT223-3L

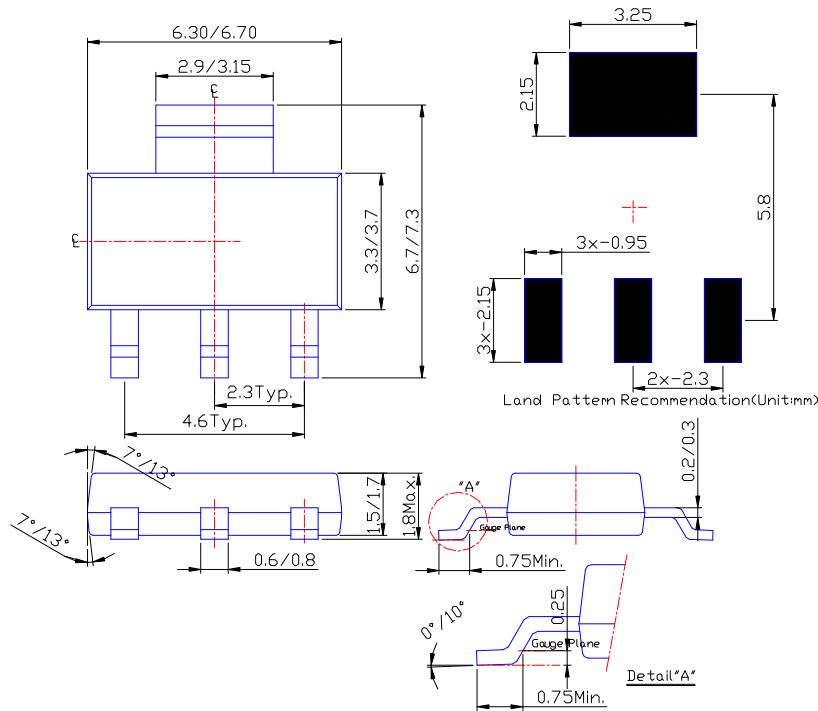

Package Information (Continued)

(2) TO252-3L

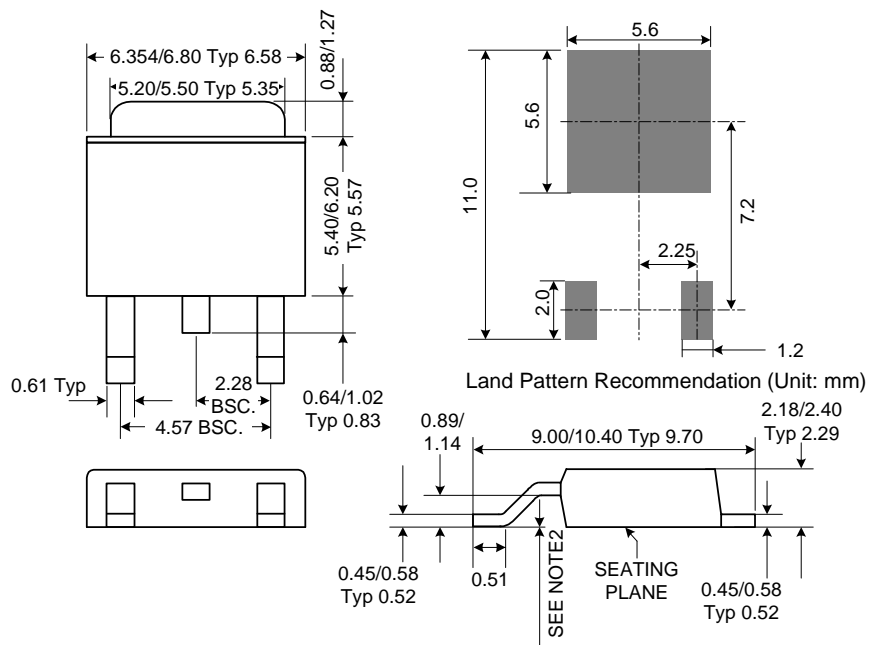

(3) SOT89-3L

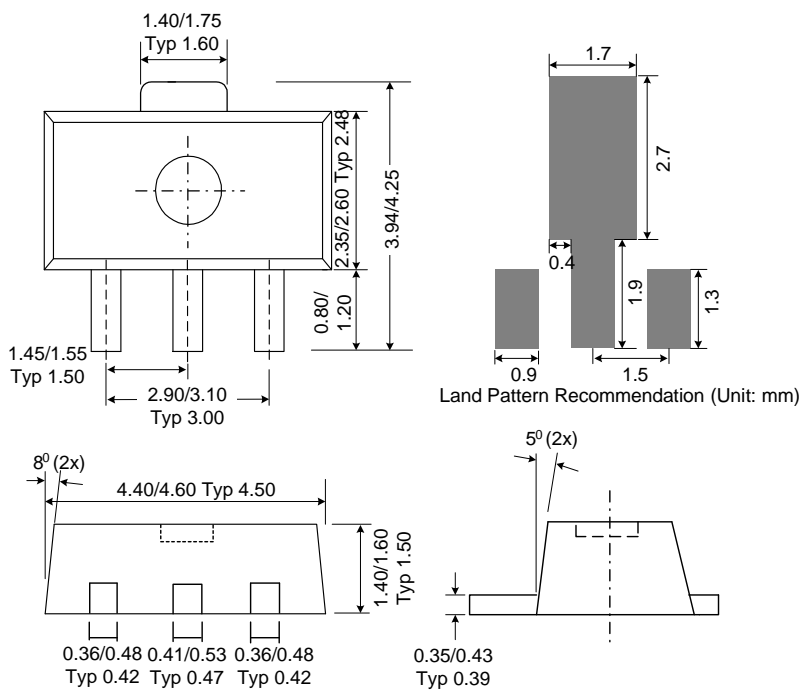

Package Information (Continued)

(4) TO263-3L

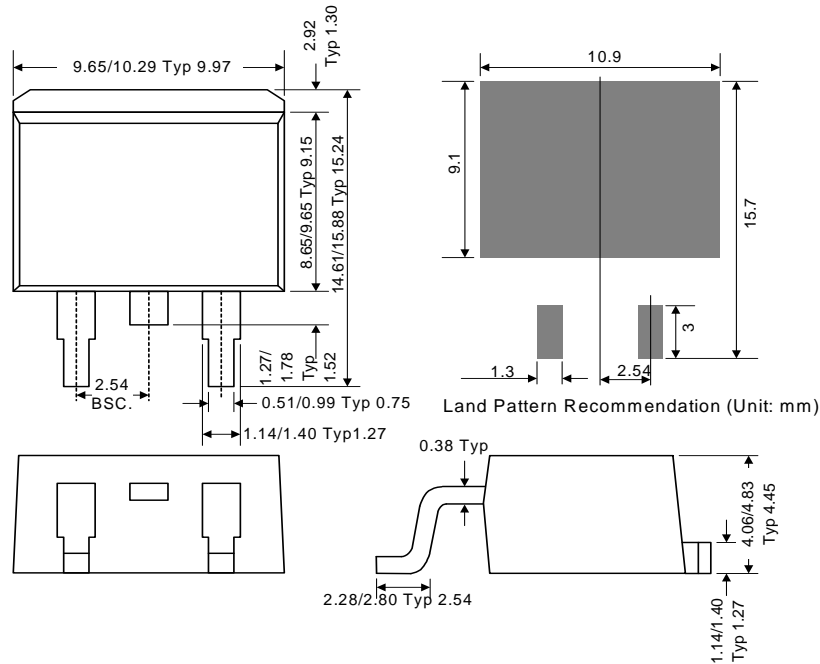

(5) TO220-3L

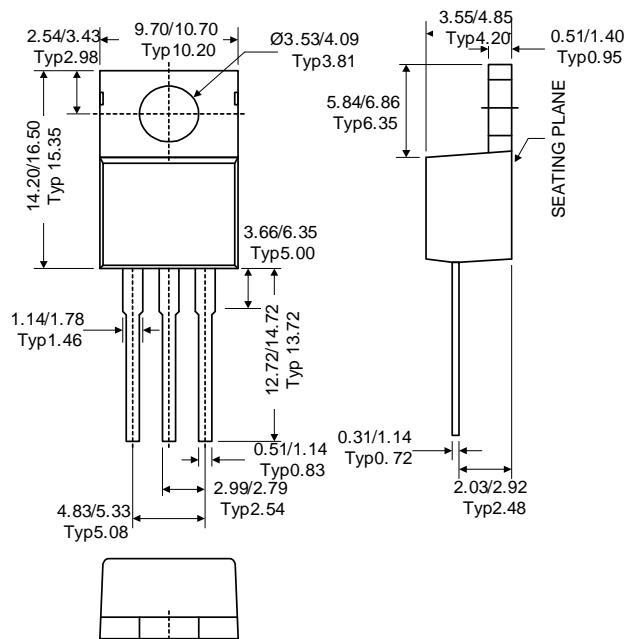

IMPORTANT NOTICE

Diodes Incorporated and its subsidiaries reserve the right to make modifications, enhancements, improvements, corrections or other changes without further notice to any product herein. Diodes Incorporated does not assume any liability arising out of the application or use of any product described herein; neither does it convey any license under its patent rights, nor the rights of others. The user of products in such applications shall assume all risks of such use and will agree to hold Diodes Incorporated and all the companies whose products are represented on our website, harmless against all damages.

LIFE SUPPORT

Diodes Incorporated products are not authorized for use as critical components in life support devices or systems without the expressed written approval of the President of Diodes Incorporated.