

Features

- Concave terminals
- Lead free version available (see How to Order "Termination" options)
- RoHS compliant*
- 8 bit multiple applications
- Smallest bussed chip array

- E 24 Series from 10 ohms to 1 megohm

CAT25 - Thick Film Chip Resistor Arrays

Electrical Characteristics

Parameters	CAT25	Test Method
Number of Resistors	8	
Resistance Range E24	10 ohms to 1 megohm	
Resistance Tolerance	5 %	JIS-C-5202.5.1
Power Rating/Resistor	62.5 mW	
Rating Temperature	+70 °C	
T.C.R.	+/-200 ppm/°C	JIS-C-5202.5.2
Maximum Operating Voltage	25 V	
Operating Temperature	-55 °C to +125 °C	

How To Order

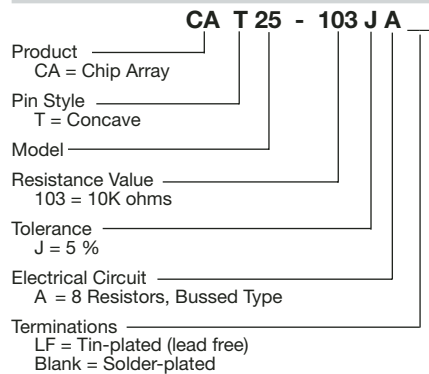

Environmental Characteristics

Specification	Characteristics	Test Method
Short Time Overload	+/- (3 % +0.1 ohm)	JIS-C-5202.5.5
Load Life	+/- (5 % +0.1 ohm)	JIS-C-5202.7.10
Humidity Load Life	+/- (3 % +0.1 ohm)	JIS-C-5202.7.9
Resistance to Soldering Heat	+/- (1 % +0.1 ohm)	JIS-C-5202.6.4
Terminal Strength	+/- (1 % +0.1 ohm)	JIS-C-5202.6
Temperature Cycle	+/- (2 % +0.1 ohm)	JIS-C-5202.7.4
Vibration	+/- (1 % +0.1 ohm)	JIS-C-5202.6.3
Insulation Resistance	1000 megohms minimum	JIS-C-5202.5.6
Dielectric Withstanding Voltage	50 VRMS	JIS-C-5202.5.7
Lead Solderability	>95 %	JIS-C-5202.6.5

For Standard Values Used in Capacitors, Inductors, and Resistors, [click here](#).

Outline Drawing

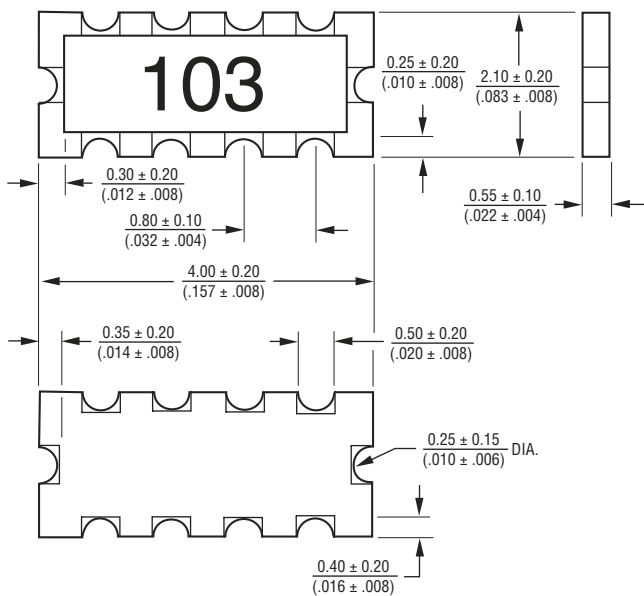

DIMENSIONS ARE: $\frac{\text{MM}}{\text{(INCHES)}}$

Land Pattern

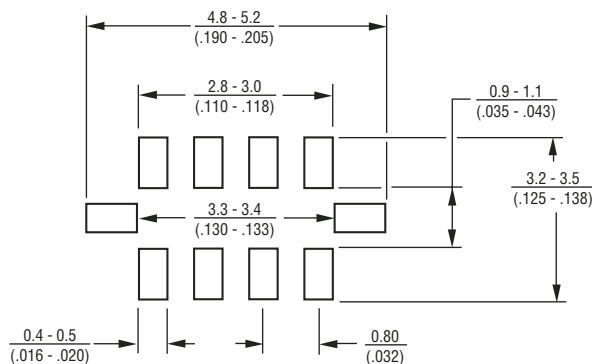

Electrical Circuit

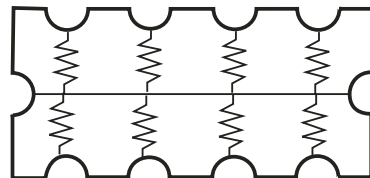

*RoHS Directive 2002/95/EC Jan 27 2003 including Annex Specifications are subject to change without notice.

Customers should verify actual device performance in their specific applications.

CAT25 - Thick Film Chip Resistor Arrays

BOURNS®

Soldering Profile for Lead Free Chip Resistors and Arrays

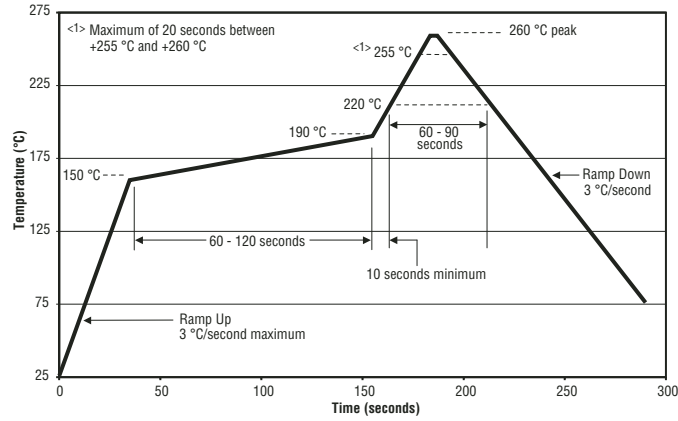

Packaging

12
(.472) embossed tape
4,000 pcs. per reel

Material

Substrate	Alumina 96
Element	Ruthenium Oxide
Coating	Glass
Terminal	AgPb, Plated Ni+SnPb

REV. 04/06

Specifications are subject to change without notice.
Customers should verify actual device performance in their specific applications.