

HPI - 304R4L

The HPI - 304R4L is a high - output, high - speed silicon photodiode mounted in a side - viewing plastic package with visible light cut - off filter. This photodiode is both compact and easy to mount.

FEATURES

- Visible ray widely cut off mold type
- High output power
- High speed response
- Long leads type 42.5mm(Min.)

APPLICATIONS

- Optical switches

DIMENSIONS

(Unit : mm)

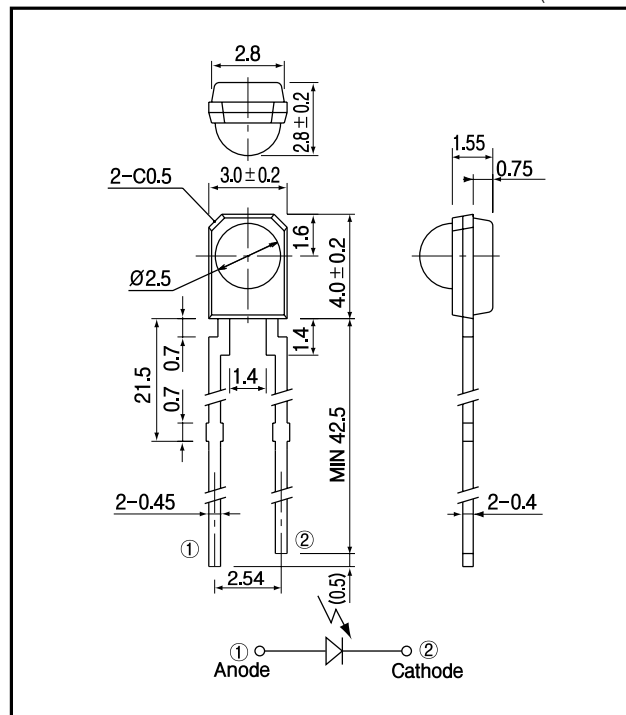

MAXIMUM RATINGS

(Ta=25)

Item	Symbol	Rating	Unit
Reverse voltage	V_R	40	V
Power dissipation	P_D	-	mW
Operating temp.	Topr.	- 30 +70	
Storage temp.	Tstg.	- 40 +80	
Soldering temp.*1	Tsol.	260	

*1.For MAX.5 seconds at the position of 2 mm from the package

ELECTRO-OPTICAL CHARACTERISTICS

(Ta=25)

Item	Symbol	Conditions	Min.	Typ.	Max.	Unit.
Short circuit current	I_{sc}	$E_v=1000lx^{-2}$	5			μA
Dark current	I_d	$V_R=10V$			20	nA
Capacitance	C_t	$V=10V, f=1MHz$		6		pF
Spectral sensitivity				860 1100		nm
Peak wavelength	λ_p			960		nm
Half angle				± 45		deg.

*2.Color temp.=2856K standard Tungsten lamp

PIN Photodiode

HPI - 304R4L

Light current Vs. Forward voltage

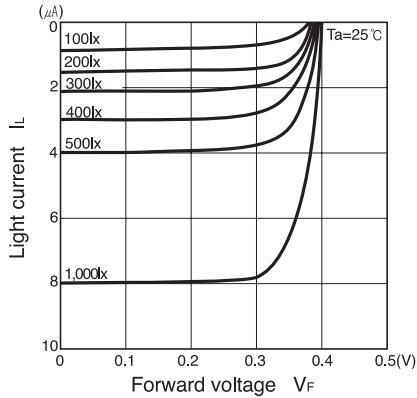

Short circuit current Vs. Illuminance

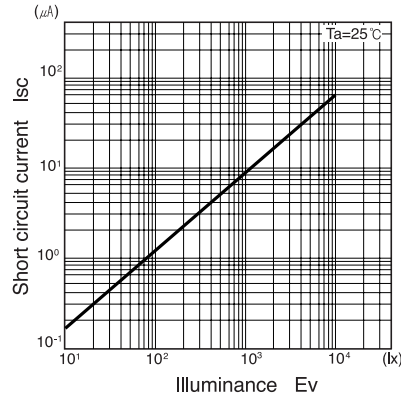

Dark current Vs. Ambient temperature

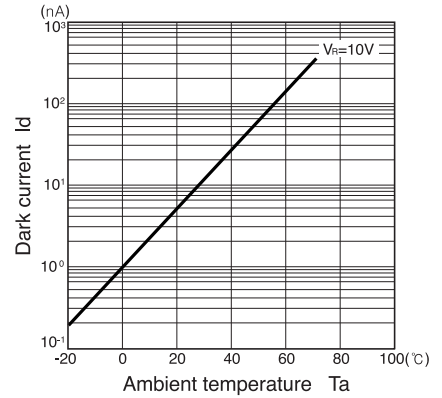

Relative sensitivity Vs. Wavelength

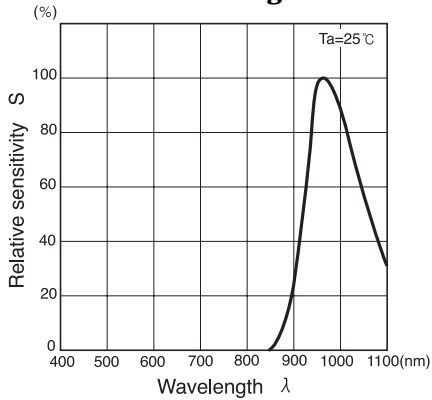

Dark current Vs. Reverse voltage

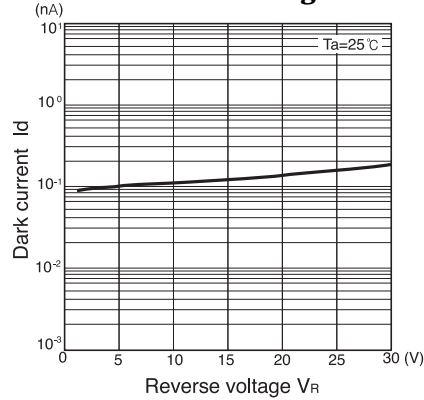

Radiant Pattern

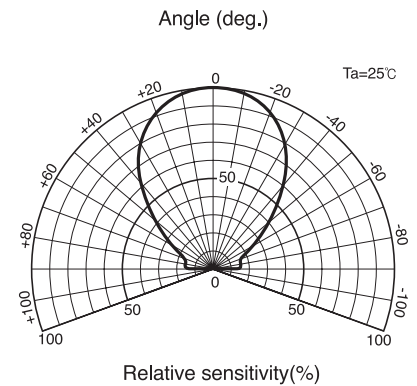

Capacitance between terminals Vs. Reverse voltage

