

## 8-Bit Dual Supply Bus Transceiver with Configurable Output Voltage and 3-State Outputs

### Product Features

- 2.7V to 3.6V on A-port and 3V to 5.5V on B-port
- Latch-up performance exceeds 200mA Per JESD78
- ESD protection exceeds JESD22
  - 2000V Human-Body Model (A114-B)
  - 200V Machine Model (A115-A)
- Industrial Temperature:  $-40^{\circ}\text{C}$  to  $+85^{\circ}\text{C}$
- Packages (Pb-free available):
  - 24-pin 173-mil wide plastic TSSOP (L)
  - (Pb-free & Green available)
  - 24-pin 150-mil wide plastic QSOP (Q)
  - 24-pin 300-mil wide plastic SOIC (S)

### Product Description

Pericom Semiconductor's PI74LVC series of logic circuits are produced using the Company's advanced submicron CMOS technology, achieving industry leading speed.

The PI74LVCC3245A is a non-inverting 8-bit Bidirectional Transceiver that uses two separate power supply rails. A-port ( $V_{CCA}$ ) is set to operate at 3.3V and B-port ( $V_{CCB}$ ) is set to operate from 3.3V to 5V. This allows for translation from a 3.3V to a 5V environment and vice-versa. This transceiver is designed for asynchronous two-way communication between data buses. The direction control input pin (DIR) determines the dataflow from the A bus to the B bus or from the B bus to the A bus. The output enable ( $\overline{OE}$ ) input, when HIGH, disables both A and B ports by placing them in HIGH Z condition.

### Logic Block Diagram

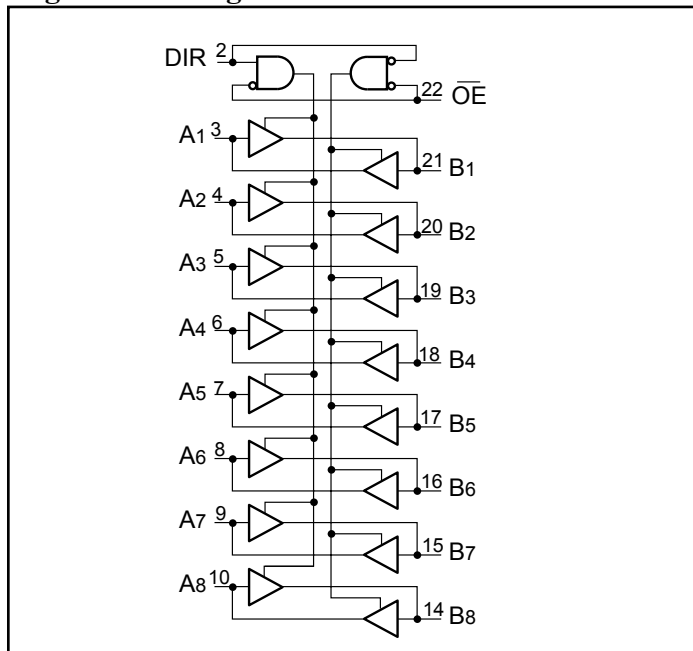

### Product Pin Configuration

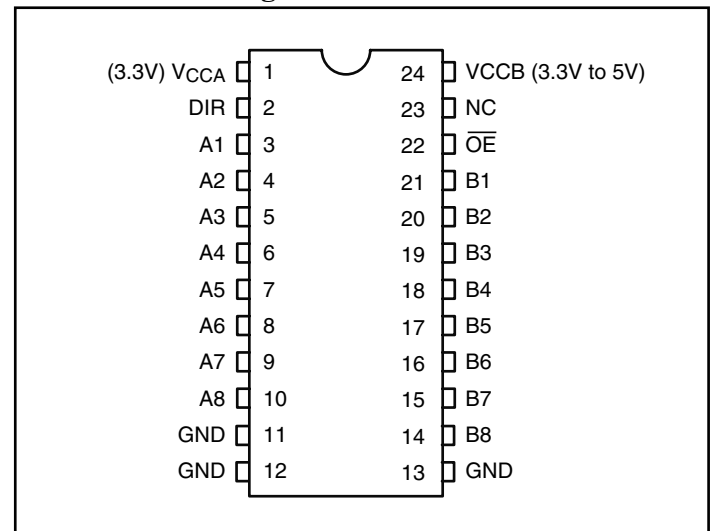

### Truth Table<sup>(1)</sup>

Inputs		Outputs
$\overline{OE}$	DIR	
L	L	Bus B Data to Bus A
L	H	Bus A Data to Bus B
H	X	Z (Isolation)

#### Note:

1. H = High Signal Level      L = Low Signal Level  
 X = Don't Care or Irrelevant      Z = High Impedance

### Product Pin Description

Pin Name	Description
$\overline{OE}$	3-State Output Enable Inputs (Active LOW)
DIR	Direction Control Input
Ax	Side A Inputs or 3-State Outputs
Bx	Side B Inputs or 3-State Outputs
NC	NO Internal Connect
GND	Ground
$V_{CCA}, V_{CCB}$	Power

### Maximum Ratings

(Above which the useful life may be impaired. For user guidelines, not tested.)

Supply voltage range, $V_{CCA}$ and $V_{CCB}$	-0.5V to +7V
Input voltage range, $V_I^{(2)}$ : I/O ports (A-port)	-0.5V to $V_{CCA} + 0.5V$
I/O ports (B-port)	-0.5V to $V_{CCB} + 0.5V$
Control Pins	-0.5V to $V_{CCA} + 0.5V$
Input clamp current, $I_{IK}$ ( $V_I < 0$ )	-50mA
Output clamp current, $I_{OK}$ ( $V_O < 0$ )	-50mA
Continuous Output Current $I_O$	$\pm 50mA$
Continuous Current through each $V_{CC}$ or GND pin	$\pm 100mA$
Package thermal impedance, $\theta_{JA}^{(3)}$ : package L	84°C/W
package Q	98°C/W
package S	79°C/W
Storage Temperature range, $T_{stg}$	-65°C to 150°C

**Notes:**

Stresses greater than those listed under MAXIMUM RATINGS may cause permanent damage to the device. This is a stress rating only and functional operation of the device at these or any other conditions above those indicated in the operational sections of this specification is not implied. Exposure to absolute maximum rating conditions for extended periods may affect reliability.

2. This value is limited to 7V maximum.

3. The package thermal impedance is calculated in accordance with JESD 51.

**Recommended Operating Conditions<sup>(4)</sup>**

Parameter	Description		V <sub>CCA</sub>	V <sub>CCB</sub>	Min.	Nom.	Max.	Units
V <sub>CCA</sub>	Supply Voltage				2.7	3.3	3.6	V
V <sub>CCB</sub>	Supply Voltage				3	5	5.5	
V <sub>IHA</sub>	High-Level Input Voltage	V <sub>OB</sub> ≤ 0.1V or V <sub>OB</sub> ≥ V <sub>CCB</sub> - 0.1V	2.7V	3V	2			
			3.0V	3.6V	2			
			3.6V	5.5V	2			
V <sub>IHB</sub>	High-Level Input Voltage	V <sub>OA</sub> ≤ 0.1V or V <sub>OA</sub> ≥ V <sub>CCA</sub> - 0.1V	2.7V	3V	2			
			3.0V	3.6V	2			
			3.6V	5.5V	3.85			
V <sub>ILA</sub>	Low-Level Input Voltage	V <sub>OB</sub> ≤ 0.1V or V <sub>OB</sub> ≥ V <sub>CCB</sub> - 0.1V	2.7V	3V			0.8	
			3.0V	3.6V			0.8	
			3.6V	5.5V			0.8	
V <sub>ILB</sub>	Low-Level Input Voltage	V <sub>OA</sub> ≤ 0.1V or V <sub>OA</sub> ≥ V <sub>CCA</sub> - 0.1V	2.7V	3V			0.8	
			3.0V	3.6V			0.8	
			3.6V	5.5V			1.65	
V <sub>IH</sub>	High-Level Input Voltage (Control Pins)	V <sub>OA</sub> ≤ 0.1V or V <sub>OA</sub> ≥ V <sub>CCA</sub> - 0.1V, or V <sub>OB</sub> ≤ 0.1V or V <sub>OB</sub> ≥ V <sub>CCB</sub> - 0.1V	2.7V	3V	2			
			3.0V	3.6V	2			
			3.6V	5.5V	2			
V <sub>IL</sub>	Low-Level Input Voltage (Control Pins)	V <sub>OA</sub> ≤ 0.1V or V <sub>OA</sub> ≥ V <sub>CCA</sub> - 0.1V, or V <sub>OB</sub> ≤ 0.1V or V <sub>OB</sub> ≥ V <sub>CCB</sub> - 0.1V	2.7V	3V			0.8	
			3.0V	3.6V			0.8	
			3.6V	5.5V			0.8	
V <sub>IA</sub>	Input Voltage			0		V <sub>CCA</sub>		
V <sub>IB</sub>	Input Voltage			0		V <sub>CCB</sub>		
V <sub>OA</sub>	Output Voltage			0		V <sub>CCA</sub>		
V <sub>OB</sub>	Output Voltage			0		V <sub>CCB</sub>		
I <sub>OHA</sub>	High-level output Current		2.7V	3V			-12	mA
			3.3V	3V			-24	
I <sub>OHB</sub>	High-level output Current		2.7V	3.3V			-12	
			3.3V	3V			-24	
I <sub>OLA</sub>	Low-level output Current		2.7V	3V			12	
			3.3V	3V			24	
I <sub>OLB</sub>	Low-level output Current		2.7V	3.3V			12	
			3.3V	3V			24	
Δt/Δv	Input transition Rise or Fall Rate						10	ns/v
T <sub>A</sub>	Operating Free-Air Temperature				-40		85	°C

**Note:** 4. All unused inputs of the device must be held at the associated V<sub>CC</sub> or GND to ensure proper device operation.

**DC Electrical Characteristics** (Over the Operating Range,  $T_A = -40^\circ\text{C}$  to  $+85^\circ\text{C}$ )

Parameters	Description	Test Conditions	V <sub>CCA</sub>	V <sub>CCB</sub>	Min.	Typ.	Max.	Units	
V <sub>OHA</sub>	Minimum High Level Output Voltage (Port A)	I <sub>OH</sub> = -100μA	3V	3V	2.9	3		V	
		I <sub>OH</sub> = -12mA	2.7V	3V	2.2	2.5			
			3V	3V	2.4	2.8			
		I <sub>OH</sub> = -24mA	3V	3V	2.2	2.6			
2.7V	4.5V		2	2.4					
V <sub>OHB</sub>	Minimum High Level Output Voltage (Port B)	I <sub>OH</sub> = -100μA	3V	3V	2.9	3			
		I <sub>OH</sub> = -12mA	2.7V	3V	2.4	2.8			
			3V	3V	2.2	2.6			
		I <sub>OH</sub> = -24mA	2.7V	4.5V	3.2	4.2			
V <sub>OLA</sub>	Maximum Low Level Output Voltage (Port A)		I <sub>OL</sub> = 100μA	3V	3V			0.1	
		I <sub>OL</sub> = 12mA	2.7V	3V		0.1	0.5		
			3V	3V		0.2	0.5		
		I <sub>OL</sub> = 24mA	2.7V	4.5V		0.2	0.5		
V <sub>OLB</sub>	Maximum Low Level Output Voltage (Port B)		I <sub>OL</sub> = 100μA	3V	3V			0.1	
		I <sub>OL</sub> = 12mA	2.7V	3V		0.1	0.5		
			3V	3V		0.2	0.5		
		I <sub>OL</sub> = 24mA		4.5V		0.2	0.5		
I <sub>I</sub>	Maximum Input Leakage Current (Control Inputs)		V <sub>I</sub> = V <sub>CCA</sub> or GND	3.6V	3.6V			±1	
				5.5V			±1		
I <sub>OZ</sub> <sup>(5)</sup>	Maximum 3-State Output Leakage Current (A or B ports)	V <sub>I</sub> = V <sub>IL</sub> or V <sub>IH</sub> , $\overline{\text{OE}} = V_{CCA}$ V <sub>O</sub> = V <sub>CCA/B</sub> or GND	3.6V	3.6V				±5	
I <sub>CCA</sub>	Quiescent V <sub>CCA</sub> Supply Current	A port = V <sub>CCA</sub> or GND, I <sub>O</sub> = 0	3.6V	Open				10	μA
		B to A, B-Port = V <sub>CCB</sub> or GND, I <sub>O</sub> (A port) = 0	3.6V	3.6V				10	
				5.5V				10	
I <sub>CCB</sub>	Quiescent V <sub>CCB</sub> Supply Current	A to B, A port = V <sub>CCA</sub> or GND, I <sub>O</sub> (B port) = 0	3.6V	3.6V				10	
				5.5V				10	
I <sub>CC</sub> <sup>(6)</sup>	I <sub>CC</sub> per input (A port)	One input V <sub>I</sub> = V <sub>CCA</sub> - 0.6V, other inputs = V <sub>CCA</sub> or GND, $\overline{\text{OE}} = \text{GND}$ and DIR = V <sub>CCA</sub>	3.6V	3.6V				50	μA
	I <sub>CC</sub> per input ( $\overline{\text{OE}}$ )	V <sub>I</sub> = V <sub>CCA</sub> - 0.6V, other inputs = V <sub>CCA</sub> or GND, DIR = V <sub>CCA</sub>	3.6V	3.6V				50	
	I <sub>CC</sub> per input (DIR)	V <sub>I</sub> = V <sub>CCA</sub> - 0.6V, other inputs = V <sub>CCA</sub> or GND, $\overline{\text{OE}} = \text{GND}$	3.6V	3.6V				50	
	I <sub>CC</sub> per input (B Port)	One Input V <sub>I</sub> = V <sub>CCB</sub> - 2.1V, other inputs = V <sub>CCB</sub> or GND, $\overline{\text{OE}} = \text{GND}$ and DIR = GND	3.6V	5.5V		0.7	1.5	mA	

**Notes:**

5. For I/O ports, the parameter I<sub>OZ</sub> includes the input leakage current.

6. This is the increase in supply current for each input that is at one of the specified voltage levels, rather than 0V or the associated V<sub>CC</sub>.

**Capacitance** ( $T_A = 25^\circ\text{C}$ )

Parameters	Description	Test Conditions		Typ.	Units
$C_{IN}$	Control Input Capacitance	$V_I = V_{CCA}$ or GND, $V_{CCA} = \text{Open}$ , $V_{CCB} = \text{Open}$		2.6	pF
$C_{I/O}$	Input/Output Capacitance (A or B port)	$V_{I/O} = V_{CCA/B}$ or GND, $V_{CCA} = 3.3\text{V}$ , $V_{CCB} = 5\text{V}$		9	
$C_{PD}$	Power Dissipation Capacitance <sup>(7)</sup>	Outputs Enabled	$V_{CCA} = 3.3\text{V}$ , $V_{CCB} = 5\text{V}$ $C_L = 0\text{pF}$ , $f = 10\text{MHz}$	22	
		Outputs Disabled		2.4	

**Notes:**

7.  $C_{PD}$  is defined as the value of the internal equivalent capacitance which is derived from dynamic operating current consumption ( $I_{CCD}$ ) at no output loading and operating at 50% duty cycle,  $C_{PD}$  is related to  $I_{CCD}$  dynamic operating current by the expression:  $I_{CCD} = (C_{PD})(V_{CC})(f_{IN}) + (I_{CC} \text{ static})$

**AC Electrical Characteristics** (Over Operating Range,  $T_A = -40^\circ\text{C}$  to  $+85^\circ\text{C}$ )

Parameters	From (Input)	To (Output)	$V_{CCA} = 2.7\text{V to } 3.6\text{V}$ , $V_{CCB} = 5\text{V} \pm 0.5\text{V}$		$V_{CCA} = 2.7\text{V to } 3.6\text{V}$ , $V_{CCB} = 3.3\text{V} \pm 0.3\text{V}$		Units
			$C_L = 50\text{pF}$ , $R_L = 500\Omega$		$C_L = 50\text{pF}$ , $R_L = 500\Omega$		
			Min.	Max.	Min.	Max.	
$t_{PHL}$	A	B	1	5.6	1	7.1	ns
$t_{PLH}$			1	5.3	1	7.2	
$t_{PHL}$	B	A	1	5.0	1	6.4	
$t_{PLH}$			1	5.2	1	6.6	
$t_{PZL}$	$\overline{OE}$	A	1	8.0	1	9.0	
$t_{PZH}$			1	7.8	1	8.8	
$t_{PZL}$	$\overline{OE}$	B	1	8.1	1	9.1	
$t_{PZH}$			1	8.4	1	8.8	
$t_{PLZ}$	$\overline{OE}$	A	1	7.1	1	7.3	
$t_{PHZ}$			1	7.3	1	7.5	
$t_{PLZ}$	$\overline{OE}$	B	1	7	1	7.5	
$t_{PHZ}$			1	7	1	7.6	
$t_{SK(O)}$	Output-to-Output Skew <sup>(8)</sup>			1.5		1.5	

**Note:**

8. Skew between any two outputs of the same device, switching in the same direction. Parameter guaranteed by design.

### Power- Up Considerations

To avoid excessive supply current, bus contention or oscillation during power-up, the following guidelines should be followed:

1. Connect ground first before any supply voltage is applied.
2. Power up  $V_{CCA}$ , which is the control side of the device.
3. Ramp  $\overline{OE}$  ahead of or with  $V_{CCA}$  to help prevent bus contention
4. Ramp DIR with  $V_{CCA}$  if DIR high is needed (A bus to B bus). Otherwise keep DIR Low.

### PARAMETER MEASUREMENT INFORMATION FOR A TO B PORT

$V_{CCA} = 2.7V$  TO  $3.6V$  and  $V_{CCB} = 5V \pm 0.5V$

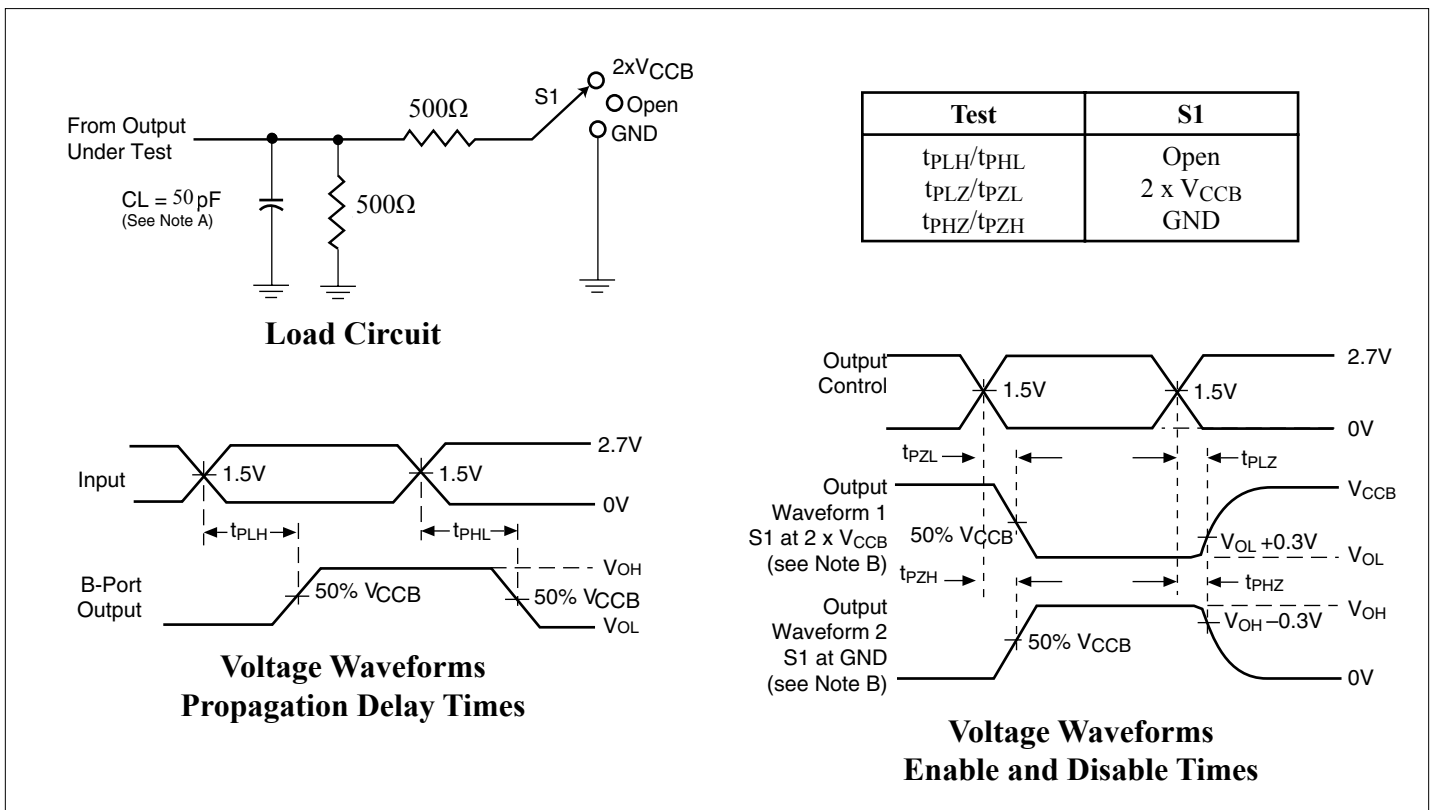

**Figure 1. Load Circuit and Voltage Waveforms**

**Notes:**

- A.  $C_L$  includes probe and jig capacitance.
- B. Waveform 1 is for an output with internal conditions such that the output is low except when disabled by the output control.  
 Waveform 2 is for an output with internal conditions such that the output is high except when disabled by the output control.
- C. All input impulses are supplied by generators having the following characteristics:  $PRR \leq 10\text{ MHz}$ ,  $Z_O = 50\Omega$ ,  $t_R \leq 2.5\text{ ns}$ ,  $t_F \leq 2.5\text{ ns}$ .
- D. The outputs are measured one at a time with one transition per measurement.

**PARAMETER MEASUREMENT INFORMATION FOR B TO A PORT**

$V_{CCA} = 2.7V$  TO  $3.6V$  and  $V_{CCB} = 5V \pm 0.5V$

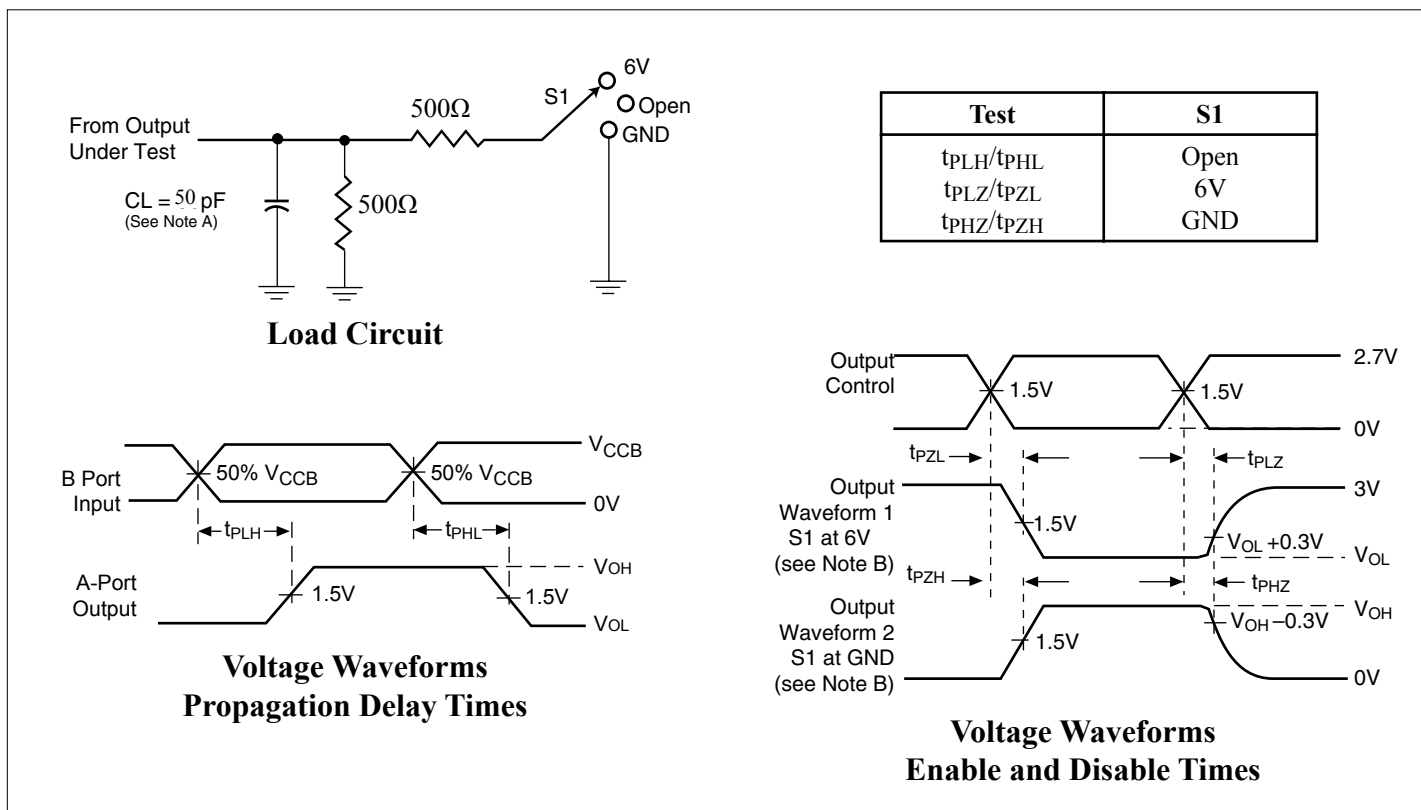
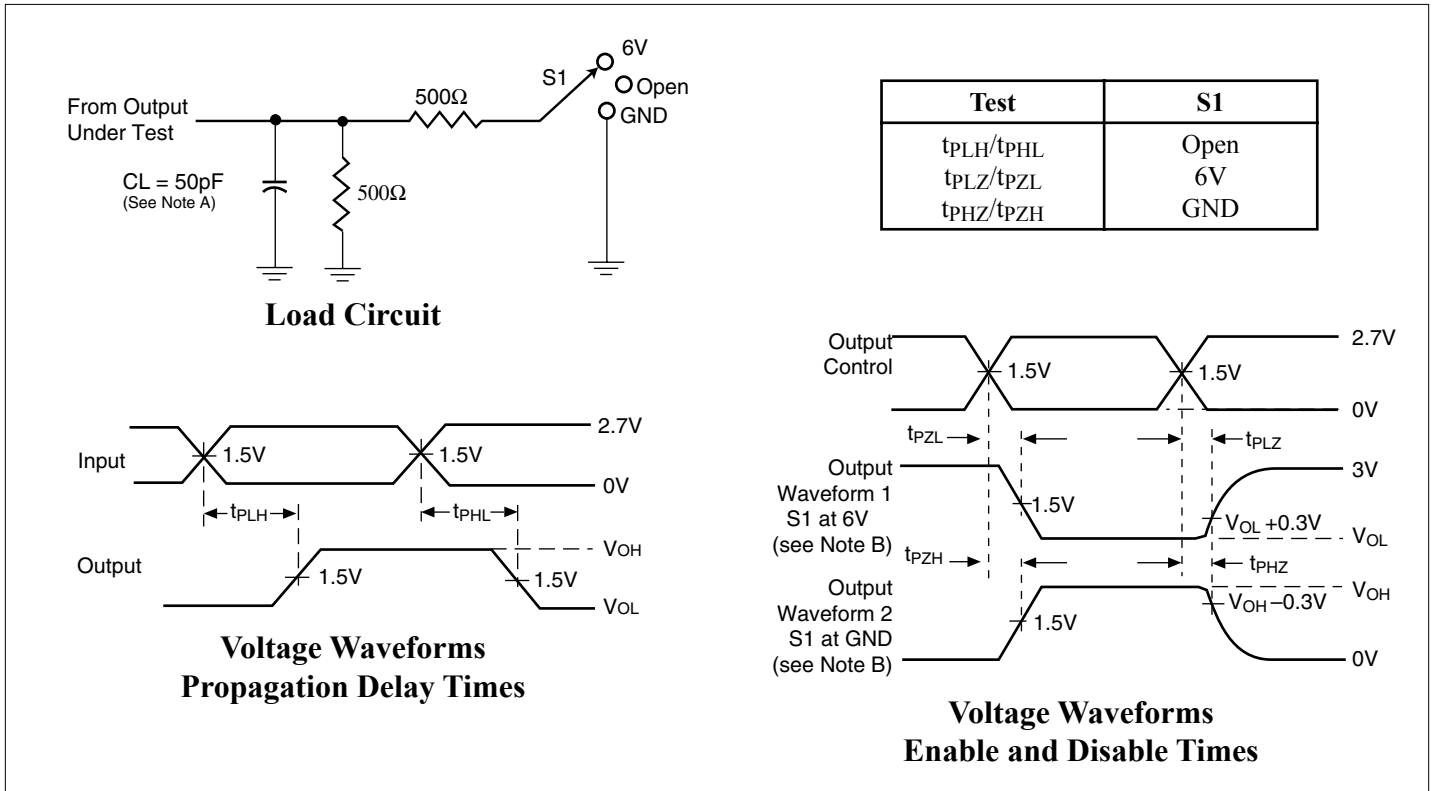

**Figure 2. Load Circuit and Voltage Waveforms**

**Notes:**

- A.  $C_L$  includes probe and jig capacitance.
- B. Waveform 1 is for an output with internal conditions such that the output is low except when disabled by the output control.  
Waveform 2 is for an output with internal conditions such that the output is high except when disabled by the output control.
- C. All input impulses are supplied by generators having the following characteristics:  $PRR \leq 10 \text{ MHz}$ ,  $Z_O = 50\Omega$ ,  $t_R \leq 2.5\text{ns}$ ,  $t_F \leq 2.5\text{ns}$ .
- D. The outputs are measured one at a time with one transition per measurement.

**PARAMETER MEASUREMENT INFORMATION FOR A TO B AND B TO A**  
 **$V_{CCA} = 2.7V$  TO  $3.6V$  and  $V_{CCB} = 3.3V \pm 0.3V$**



**Figure 2. Load Circuit and Voltage Waveforms**

**Notes:**

- A.  $C_L$  includes probe and jig capacitance.
- B. Waveform 1 is for an output with internal conditions such that the output is low except when disabled by the output control.  
 Waveform 2 is for an output with internal conditions such that the output is high except when disabled by the output control.
- C. All input impulses are supplied by generators having the following characteristics:  $PRR \leq 10$  MHz,  $Z_O = 50\Omega$ ,  $t_R \leq 2.5$ ns,  $t_F \leq 2.5$ ns.
- D. The outputs are measured one at a time with one transition per measurement.



### Packaging Mechanical: 24-pin TSSOP (L)

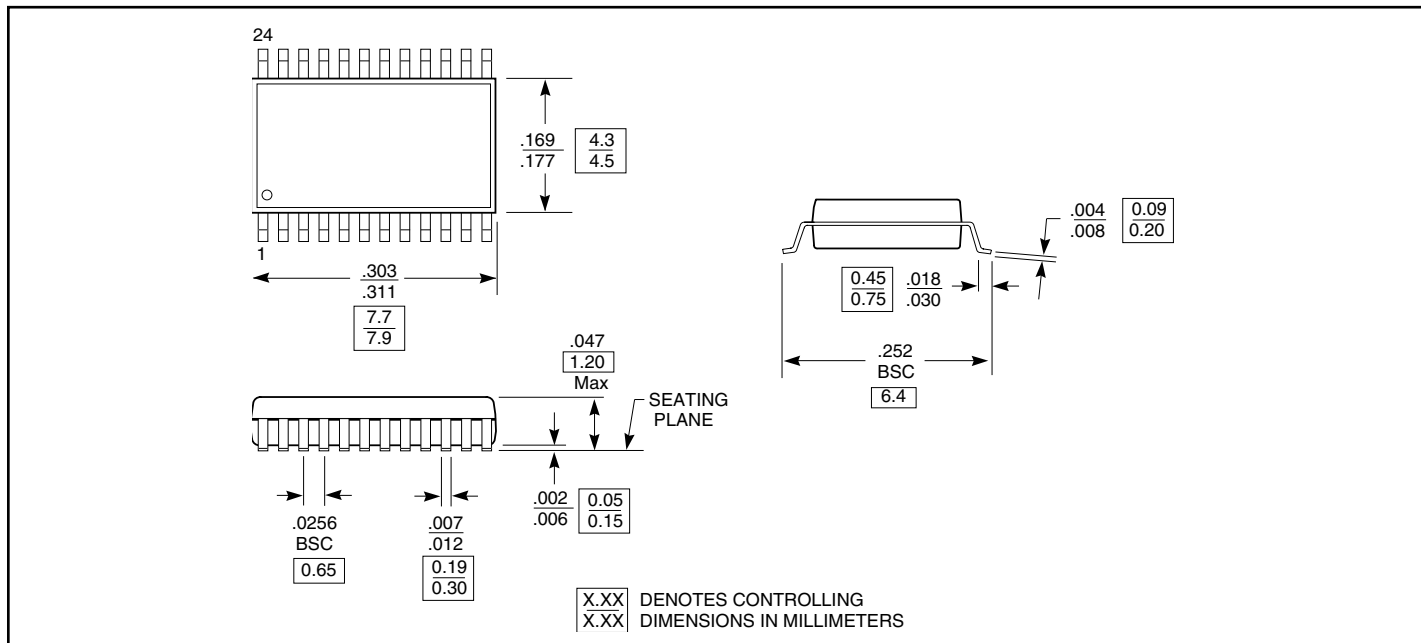

### Packaging Mechanical: 24-pin QSOP (Q)

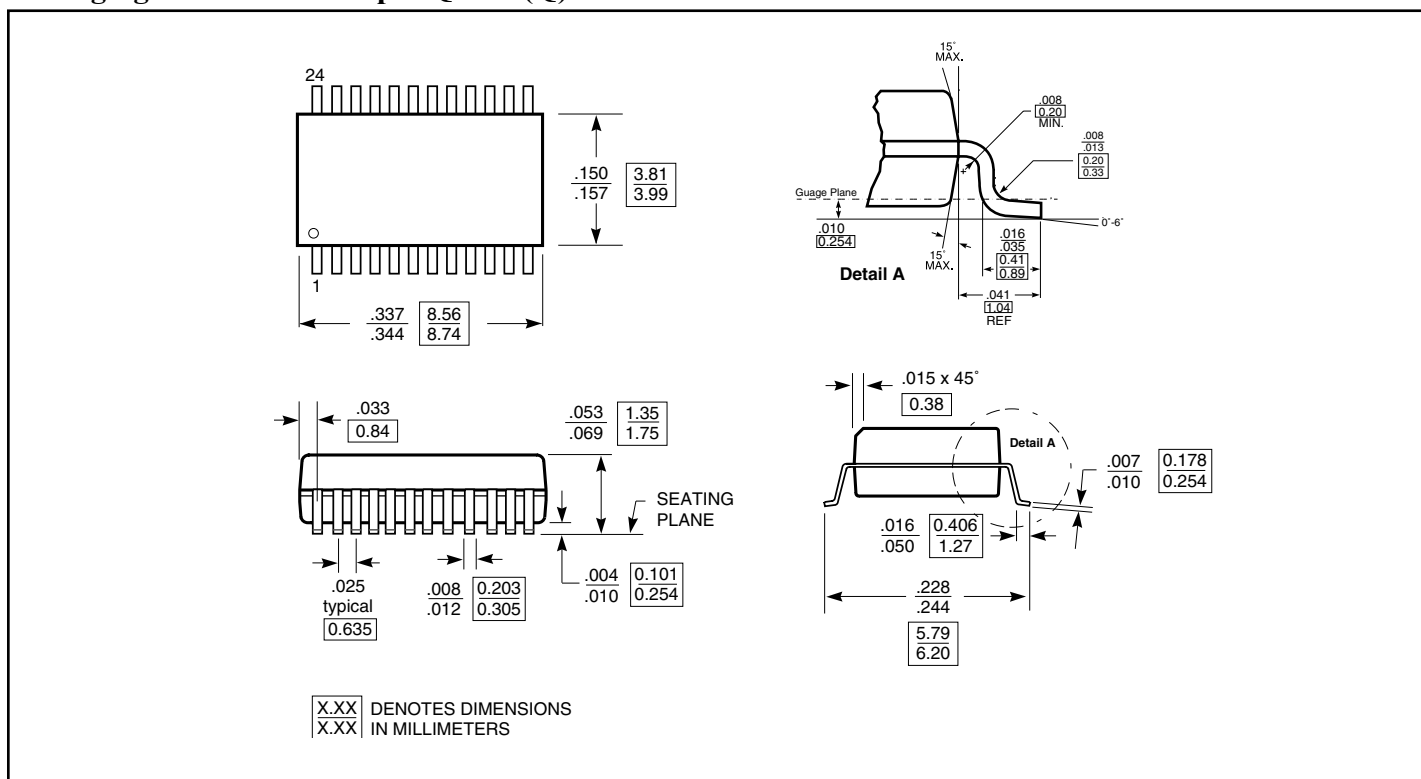

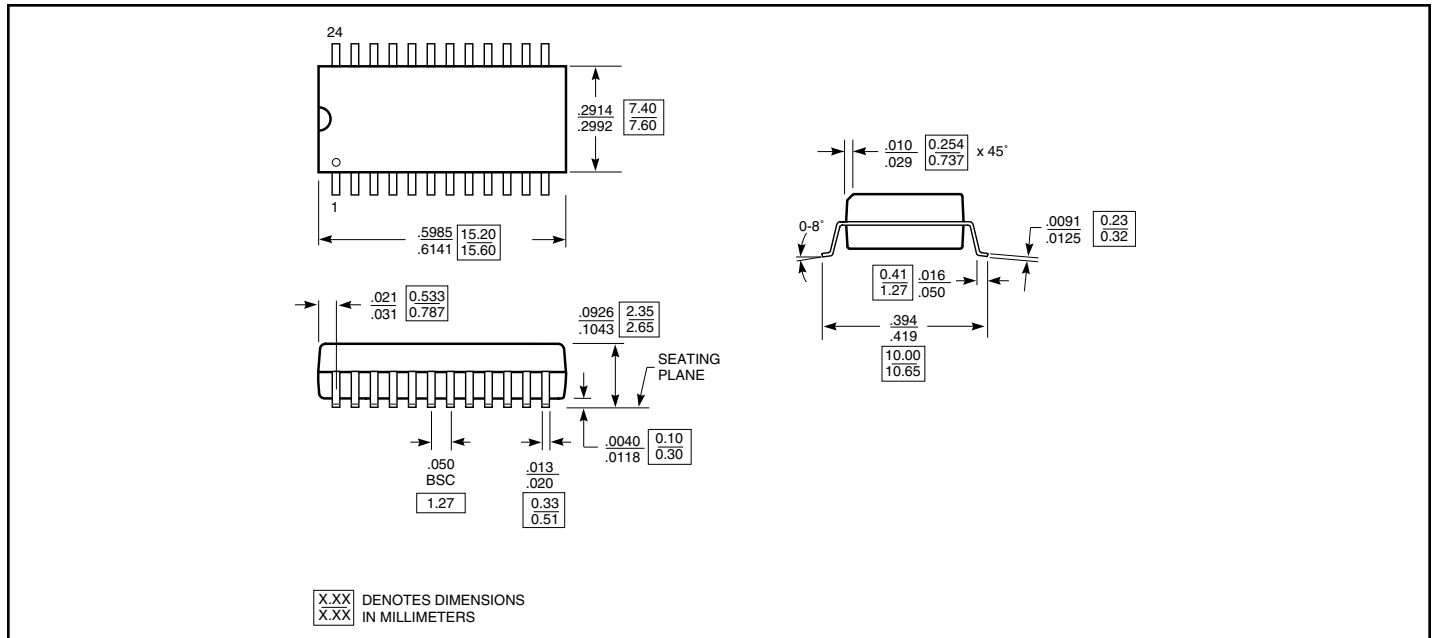
**Packaging Mechanical: 24-pin SOIC (S)**

**Ordering Information**

Ordering Code	Package Code	Package Description
PI74LVCC3245AL	L	24-pin, 173-mil wide plastic TSSOP
PI74LVCC3245ALE	L	Pb-free, 24-pin, 173-mil wide plastic TSSOP
PI74LVCC3245AQ	Q	24-pin, 150-mil wide plastic QSOP
PI74LVCC3245AS	S	24-pin, 300-mil wide plastic SOIC

**Notes:**

1. Thermal characteristics can be found on the company web site at <http://www.pericom.com/packaging/>