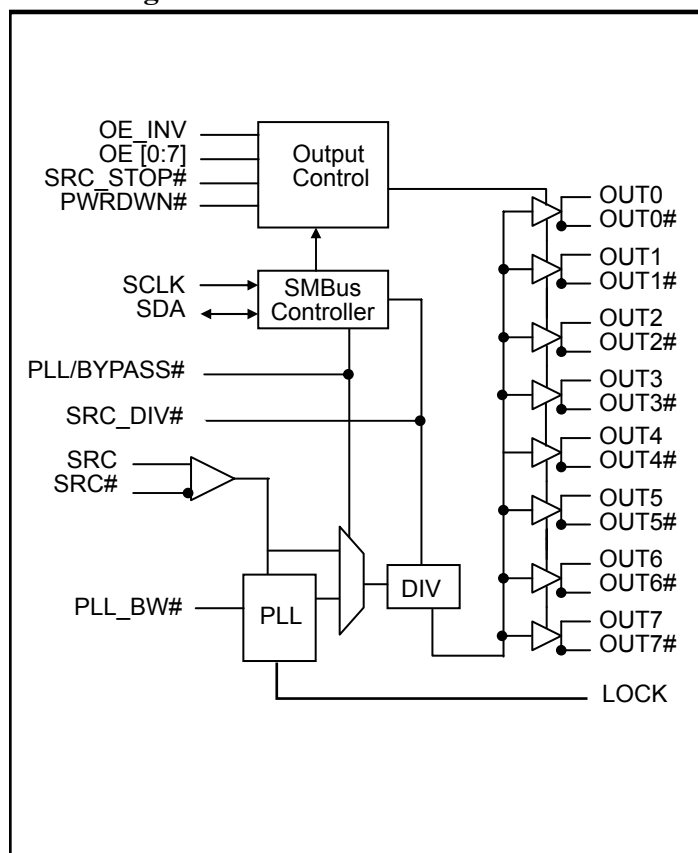
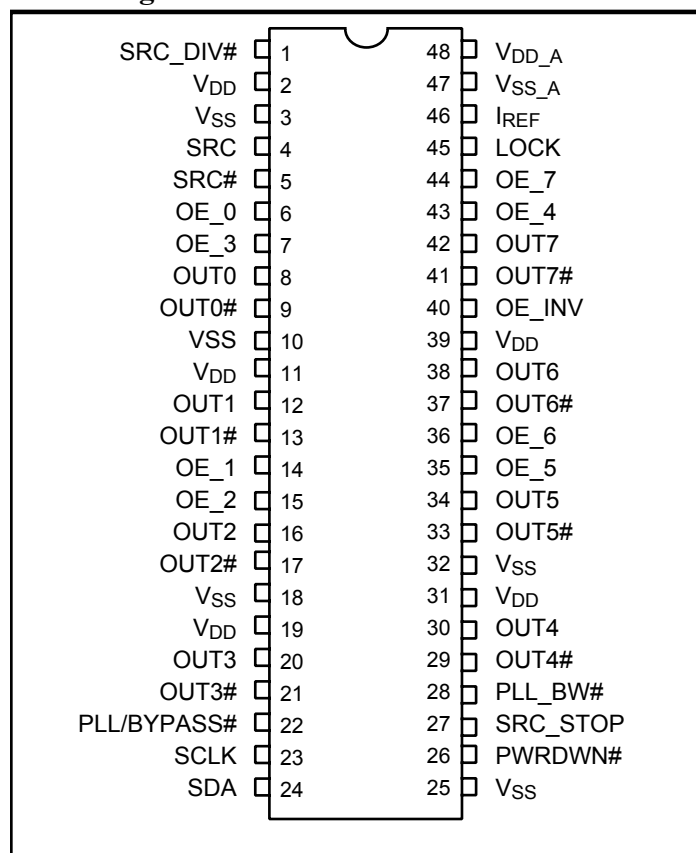

**1:8 Clock Driver for Intel  
PCI Express Chipsets**
**Features**

- Eight Pairs of Differential Clocks
- Low skew < 50ps
- Low Cycle-to-cycle jitter < 50ps
- Output Enable for all outputs
- Outputs Tristate control via SMBus
- Power Management Control
- Programmable PLL Bandwidth
- PLL or Fanout operation
- 3.3V Operation
- Packaging (Pb-Free & Green):
  - 48-Pin SSOP (V)
  - 48-Pin TSSOP (A)

**Description**

PI6C20800 is a high-speed, low-noise differential clock buffer designed to be a companion to PI6C410B. The device distributes the differential SRC clock from PI6C410B to eight differential pairs of clock outputs either with or without PLL. The input SRC clock can be divided by 2 when SRC\_DIV# is LOW. The clock outputs are controlled by input selection of SRC\_STOP#, PWRDWN# and SMBus, SCLK and SDA. When input of either SRC\_STOP# or PWRDWN# is LOW, the output clocks are Tristated. When PWRDWN# is LOW, the SDA and SCLK inputs must be Tristated.

**Block Diagram**

**Pin Configuration**

### Pin Descriptions

Pin Name	Type	Pin #	Descriptions
SRC_DIV#	Input	1	3.3V LVTTL input for selecting input frequency divide by 2, active LOW.
SRC & SRC#	Input	4, 5	0.7V Differential SRC input from PI6C410 clock synthesizer
OE [0:7]	Input	6, 7, 14, 15, 35, 36, 43, 44	3.3V LVTTL input for enabling outputs, active HIGH.
OE_INV	Input	40	3.3V LVTTL input for inverting the OE, SRC_STOP# and PWRDWN# pins. When 0 = same stage When 1 = OE[0:7], SRC_STOP#, PWRDWN# inverted.
OUT[0:7] & OUT[0:7]#	Output	8, 9, 12, 13, 16 17, 20, 21, 29, 30, 33, 34, 37, 38, 41, 42	0.7V Differential outputs
PLL/BYPASS#	Input	22	3.3V LVTTL input for selecting fan-out of PLL operation.
SCLK	Input	23	SMBus compatible SCLOCK input
SDA	I/O	24	SMBus compatible SDATA
IREF	Input	46	External resistor connection to set the differential output current
SRC_STOP#	Input	27	3.3V LVTTL input for SRC stop, active LOW
PLL_BW#	Input	28	3.3V LVTTL input for selecting the PLL bandwidth
PWRDWN#	Input	26	3.3V LVTTL input for Power Down operation, active LOW
LOCK	Output	45	3.3V LVTTL output, transition high when PLL lock is achieved (Latched output)
VDD	Power	2, 11, 19, 31, 39	3.3V Power Supply for Outputs
VSS	Ground	3, 10, 18, 25, 32	Ground for Outputs
VSS_A	Ground	47	Ground for PLL
VDD_A	Power	48	3.3V Power Supply for PLL

### Serial Data Interface (SMBus)

PI6C20800 is a slave only SMBus device that supports indexed block read and indexed block write protocol using a single 7-bit address and read/write bit as shown below.

### Address assignment

A6	A5	A4	A3	A2	A1	A0	R/W
1	1	0	1	1	1	0	0/1

### Data Protocol<sup>(1)</sup>

1 bit	7 bits	1	1	8 bits	1	8 bits	1	8 bits	1	8 bits	1	1 bit
Start bit	Slave Addr	R/W	Ack	Register offset	Ack	Byte Count = N	Ack	Data Byte 0	Ack	Data Byte N - 1	Ack	Stop bit

#### Note:

- Register offset for indicating the starting register for indexed block write and indexed block read. Byte Count in write mode cannot be 0.

**Data Byte 0: Control Register**

Bit	Descriptions	Type	Power Up Condition	Output(s) Affected	Pin
0	SRC_DIV# 0 = Divide by 2 1 = Normal	RW	1 = x1	OUT[0:7], OUT[0:7]#	NA
1	PLL/BYPASS# 0 = Fanout 1 = PLL	RW	1 = PLL	OUT[0:7], OUT[0:7]#	NA
2	PLL Bandwidth 0 = HIGH Bandwidth, 1 = LOW Bandwidth	RW	1 = Low	OUT[0:7], OUT[0:7]#	NA
3	TBD				NA
4	TBD				NA
5	TBD				NA
6	SRC_STOP# 0 = Driven when stopped 1 = Tristate	RW	0 = Driven when stopped	OUT[0:7], OUT[0:7]#	
7	PWRDWN# 0 = Driven when stopped 1 = Tristate	RW	0 = Driven when stopped	OUT[0:7], OUT[0:7]#	NA

**Data Byte 1: Control Register**

Bit	Descriptions	Type	Power Up Condition	Output(s) Affected	Pin
0	OUTPUTS enable 1 = Enabled 0 = Disabled	RW	1 = Enabled	OUT0, OUT0#	NA
1		RW	1 = Enabled	OUT1, OUT1#	NA
2		RW	1 = Enabled	OUT2, OUT2#	NA
3		RW	1 = Enabled	OUT3, OUT3#	NA
4		RW	1 = Enabled	OUT4, OUT4#	NA
5		RW	1 = Enabled	OUT5, OUT5#	NA
6		RW	1 = Enabled	OUT6, OUT6#	NA
7		RW	1 = Enabled	OUT7, OUT7#	NA

**Data Byte 2: Control Register**

Bit	Descriptions	Type	Power Up Condition	Output(s) Affected	Pin
0	Allow control of OUTPUTS with assertion of SRC_STOP# 0 = Free running 1 = Stopped with SRC_Stop#	RW	0 = Free running	OUT0, OUT0#	NA
1		RW	0 = Free running	OUT1, OUT1#	NA
2		RW	0 = Free running	OUT2, OUT2#	NA
3		RW	0 = Free running	OUT3, OUT3#	NA
4		RW	0 = Free running	OUT4, OUT4#	NA
5		RW	0 = Free running	OUT5, OUT5#	NA
6		RW	0 = Free running	OUT6, OUT6#	NA
7		RW	0 = Free running	OUT7, OUT7#	NA

**Data Byte 3: Control Register**

Bit	Descriptions	Type	Power Up Condition	Output(s) Affected	Pin
0	TBD	RW			
1		RW			
2		RW			
3		RW			
4		RW			
5		RW			
6		RW			
7		RW			

**Data Byte 4: Pericom ID Register**

Bit	Descriptions	Type	Power Up Condition	Output(s) Affected	Pin
0	Pericom ID	R	0	NA	NA
1		R	0	NA	NA
2		R	0	NA	NA
3		R	0	NA	NA
4		R	0	NA	NA
5		R	1	NA	NA
6		R	0	NA	NA
7		R	0	NA	NA

### Functionality

PWRDWN#	OUT	OUT#	SRC_Stop#	OUT	OUT#
1	Normal	Normal	1	Normal	Normal
0	$I_{REF} \times 2$ or Float	LOW	0	$I_{REF} \times 6$ or Float	LOW

### Power Down (PWRDWN# assertion)

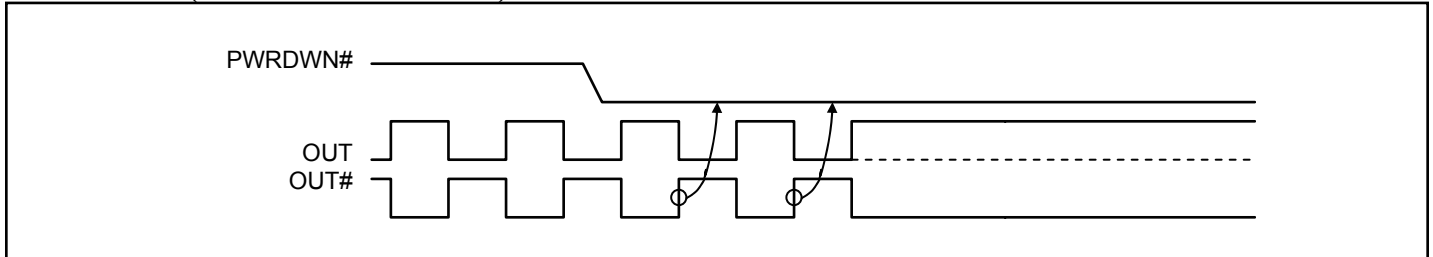

Figure 1. Power down sequence

### Power Down (PWRDWN# De-assertion)

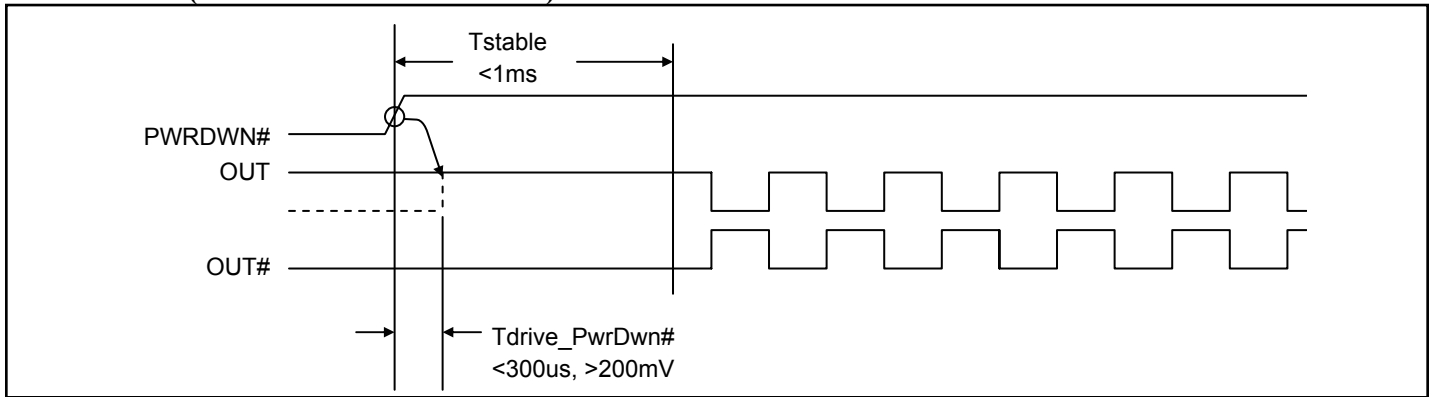

Figure 2. Power down de-assert sequence

### Current-mode output buffer characteristics of OUT[0:7], OUT[0:7]#

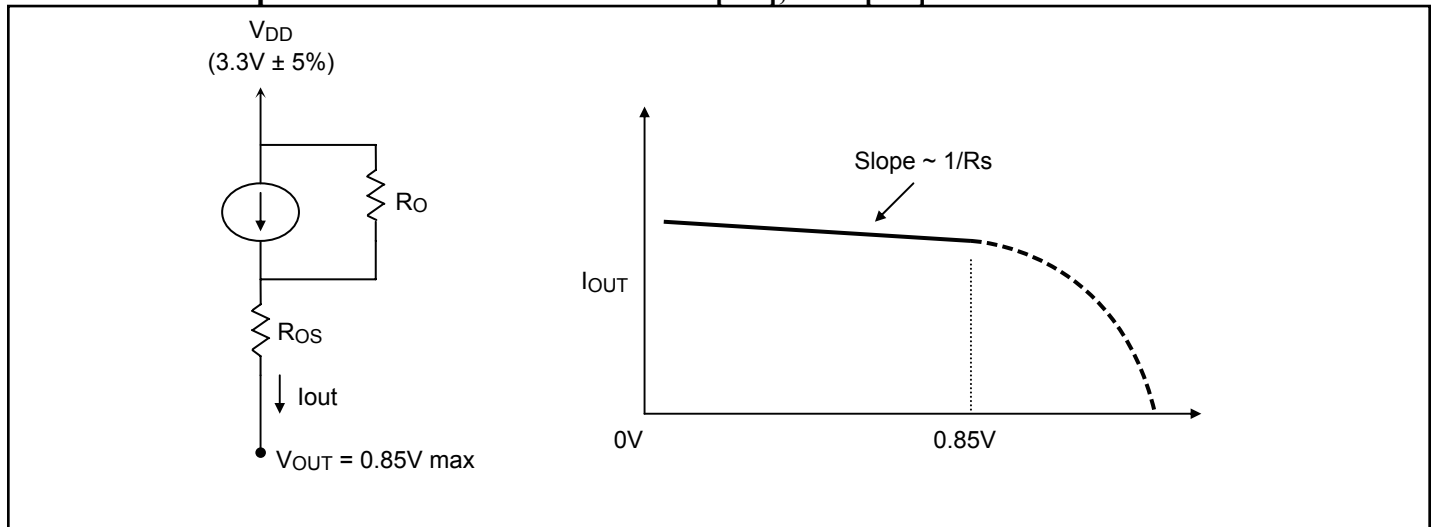

Figure 9. Simplified diagram of current-mode output buffer

### Differential Clock Buffer characteristics

Symbol	Minimum	Maximum
$R_o$	3000 $\Omega$	N/A
$R_{os}$	unspecified	unspecified
$V_{OUT}$	N/A	850mV

### Current Accuracy

Symbol	Conditions	Configuration	Load	Min.	Max.
$I_{OUT}$	$V_{DD} = 3.30 \pm 5\%$	$R_{REF} = 475\Omega \text{ } 1\%$ $I_{REF} = 2.32\text{mA}$	Nominal test load for given configuration	-12% $I_{NOMINAL}$	+12% $I_{NOMINAL}$

**Note:**

- $I_{NOMINAL}$  refers to the expected current based on the configuration of the device.

### Differential Clock Output Current

Board Target Trace/Term Z	Reference R, $I_{ref} = V_{DD}/(3 \times R_r)$	Output Current	$V_{OH} @ Z$
100 $\Omega$ (100 $\Omega$ differential $\approx$ 15% coupling ratio)	$R_{REF} = 475\Omega \text{ } 1\%$ , $I_{REF} = 2.32\text{mA}$	$I_{OH} = 6 \times I_{REF}$	0.7V @ 50

**Absolute Maximum Ratings<sup>(1)</sup>** (Over operating free-air temperature range)

Symbol	Parameters	Min.	Max.	Units
V <sub>DD_A</sub>	3.3V Core Supply Voltage	-0.5	4.6	V
V <sub>DD</sub>	3.3V I/O Supply Voltage	-0.5	4.6	
V <sub>IH</sub>	Input HIGH Voltage		4.6	
V <sub>IL</sub>	Input LOW Voltage	-0.5		
T <sub>s</sub>	Storage Temperature	-65	150	°C
V <sub>ESD</sub>	ESD Protection	2000		V

**Note:**

1. Stress beyond those listed under “Absolute Maximum Ratings” may cause permanent damage to the device.

**DC Electrical Characteristics** (V<sub>DD</sub> = 3.3±5%, V<sub>DD\_A</sub> = 3.3±5%)

Symbol	Parameters	Condition	Min.	Max.	Units
V <sub>DD_A</sub>	3.3V Core Supply Voltage		3.135	3.465	V
V <sub>DD</sub>	3.3V I/O Supply Voltage		3.135	3.465	
V <sub>IH</sub>	3.3V Input HIGH Voltage	V <sub>DD</sub>	2.0	V <sub>DD</sub> + 0.3	
V <sub>IL</sub>	3.3V Input LOW Voltage		V <sub>SS</sub> - 0.3	0.8	
I <sub>IK</sub>	Input Leakage Current	0 < V <sub>IN</sub> < V <sub>DD</sub>	-5	+5	µA
V <sub>OH</sub>	3.3V Output HIGH Voltage	I <sub>OH</sub> = -1mA	2.4		V
V <sub>OL</sub>	3.3V Output LOW Voltage	I <sub>OL</sub> = 1mA		0.4	
I <sub>OH</sub>	Output HIGH Current	I <sub>OH</sub> = 6 x I <sub>REF</sub> , I <sub>REF</sub> = 2.32mA	12.2	15.6	mA
C <sub>IN</sub>	Logic Input Pin Capacitance		1.5	5	
C <sub>OUT</sub>	Output Pin Capacitance			6	pF
L <sub>PIN</sub>	Pin Inductance			7	nH
I <sub>DD</sub>	Power Supply Current	V <sub>DD</sub> = 3.465V, F <sub>CPU</sub> = 200MHz		250	mA
I <sub>SS</sub>	Power Down Current	Driven outputs		60	
I <sub>SS</sub>	Power Down Current	Tristate outputs		12	
T <sub>A</sub>	Ambient Temperature		0	70	°C

**AC Switching Characteristics<sup>(1,2,3)</sup>** ( $V_{DD} = 3.3 \pm 5\%$ ,  $V_{DD\_A} = 3.3 \pm 5\%$ )

Symbol	Parameters	Min	Max.	Units	Notes
$T_{rise} / T_{fall}$	Rise and Fall Time (measured between 0.175V to 0.525V)	175	700	ps	2
$\Delta T_{rise} / \Delta T_{fall}$	Rise and Fall Time Variation		125		2
$T_{skew}$	Output-to-Output Skew		50	ps	3
$V_{HIGH}$	Voltage HIGH	660	850	mV	2
$V_{OVS}$	Max. Voltage		1150		
$V_{UDS}$	Min. Voltage	-300			
$V_{LOW}$	Voltage LOW	-150	+150		2
$V_{cross}$	Absolute crossing poing voltages	250	550		2
$\Delta V_{cross}$	Total Variation of $V_{cross}$ over all edges		140		2
$T_{DC}$	Duty Cycle	45	55	%	3
$T_{jycyc-cyc}$	Jitter, Cycle-to-cycle (PLL Mode, Measurement for differential waveform)		50	ps	
	Jitter, Cycle-to-cycle (BYPASS mode as additive jitter)				

**Notes:**

1. Test configuration is  $R_S = 33.2\Omega$ ,  $R_p = 49.9\Omega$ , and 2pF.
2. Measurement taken from Single Ended waveform.
3. Measurement taken from Differential waveform.

**Configuration Test Load Board Termination**

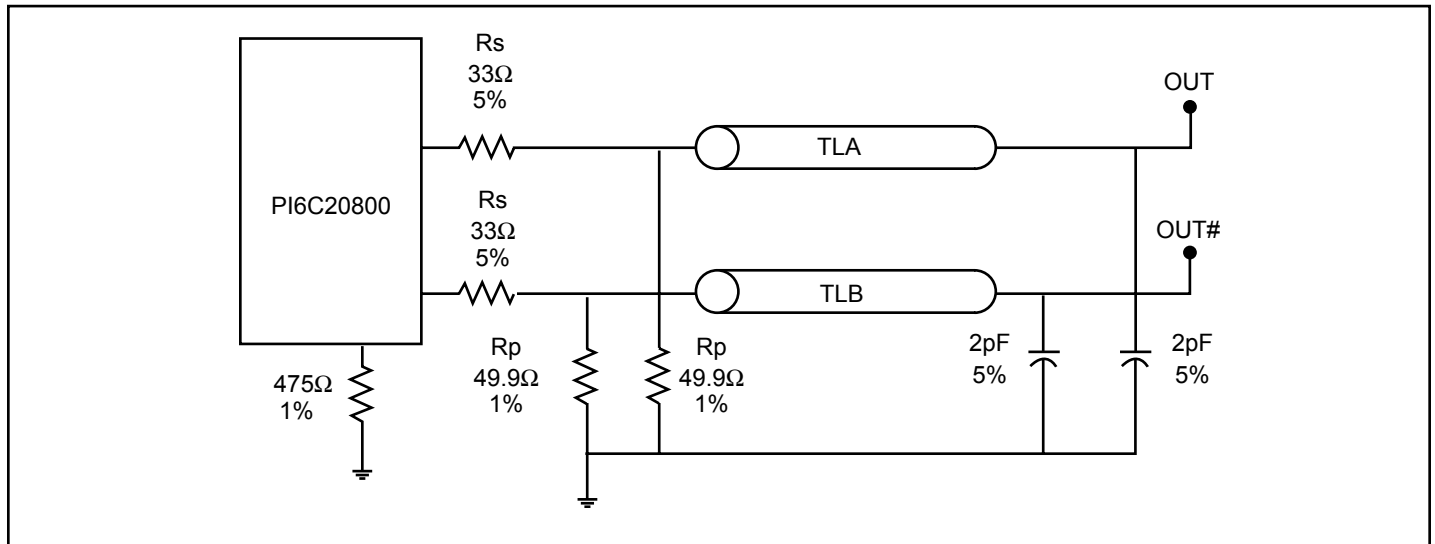



**Packaging Mechanical: 48-Pin SSOP (V)**

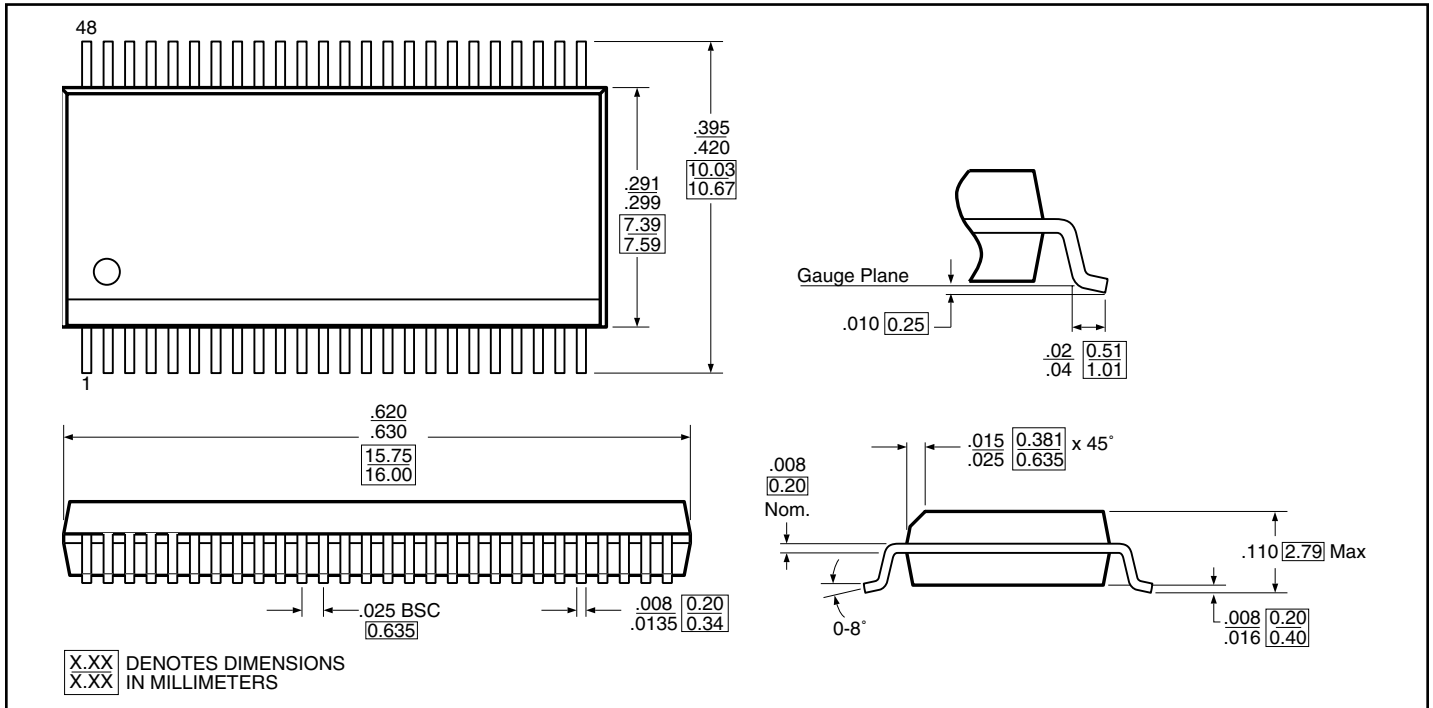

**Packaging Mechanical: 48-Pin TSSOP (A)**

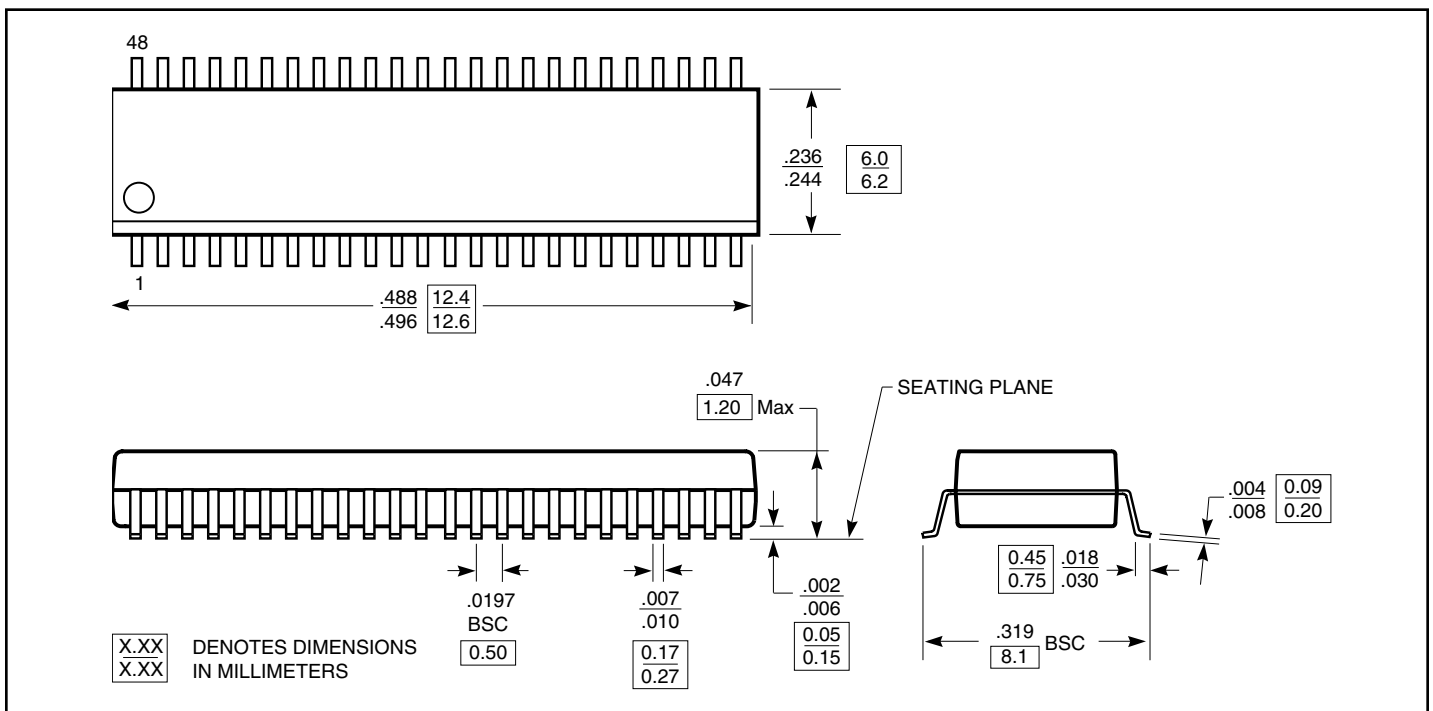

**Ordering Information**<sup>(1,2)</sup>

<b>Ordering Code</b>	<b>Package Code</b>	<b>Package Description</b>
PI6C20800VE	VE	48-pin, 300-mil wide, SSOP, Pb-Free and Green
PI6C20800AE	AE	48-pin, 240-mil wide, TSSOP, Pb-Free and Green

**Notes:**

1. Thermal characteristics can be found on the company web site at [www.pericom.com/packaging/](http://www.pericom.com/packaging/)
2. E = Pb-free and Green