

2944

QUAD HIGH-CURRENT, HIGH-VOLTAGE SOURCE DRIVER

Capable of driving loads to 4 A at supply voltages to 60 V (inductive loads to 35 V), the UDN2944W is a quad high-current, high-voltage source driver. Each of the four power drivers can provide space- and cost-saving interface between low-level signal-processing circuits and high-power loads in harsh environments.

Individual supply lines have been provided for each pair of drivers so that different supplies can be used to drive multiple loads. The controlling inputs are TTL or CMOS compatible. The outputs include transient-suppression diodes for inductive loads.

This quad Darlington array is designed to serve as an interface between low-level circuitry and peripheral-power loads such as solenoids, motors, incandescent displays, heaters, and similar loads of up to 240 W per channel. The UDN2944W is an ideal complement to the UDN2878W quad 4 A sink driver.

For maximum power-handling capability, the UDN2944W driver is supplied in a 12-pin single in-line, power-tab package that allows efficient attachment of an external heat sink for maximum allowable package power dissipation. An external heat sink is usually required for proper operation of this device. The tab is at ground potential and needs no insulation.

FEATURES

- Output Current to 4 A
- Output Voltage to 60 V
- Loads to 960 W
- Integral Output Suppression Diodes
- TTL and CMOS Compatible Inputs
- Plastic Single In-Line Package
- Heat-Sink Tab

ABSOLUTE MAXIMUM RATINGS at +25°C Free-Air Temperature

Supply Voltage Range, V_S	10 V to 60 V
Output Current, I_{OUT}	
(continuous)	-4.0 A
(peak)	-5.0 A
Input Voltage, V_{IN}	15 V
Package Power Dissipation, P_D	See Graph
Operating Temperature Range, T_A	-20°C to +85°C
Storage Temperature Range, T_S	-55°C to +150°C

Output current rating will be limited by ambient temperature, duty cycle, heat sinking, air flow, and number of outputs conducting. Under any set of conditions, do not exceed the -5.0 A peak current or a junction temperature of +150°C.

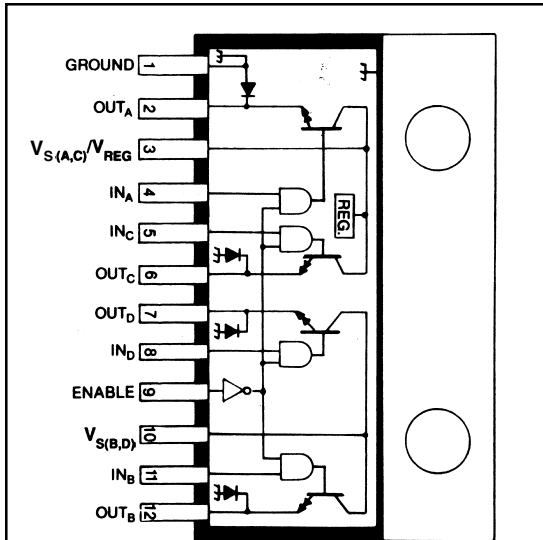

Dwg. No. A-13,054

Always order by complete part number: **UDN2944W**.



2944 QUAD HIGH-CURRENT, HIGH-VOLTAGE SOURCE DRIVER

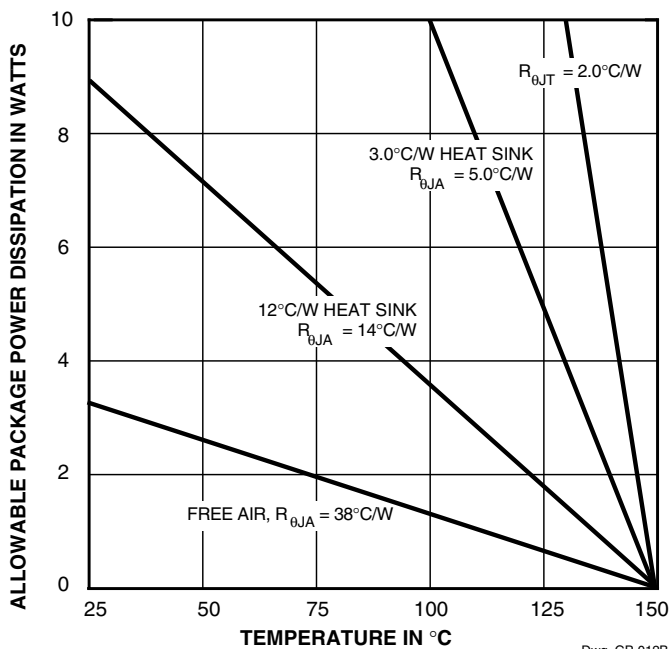
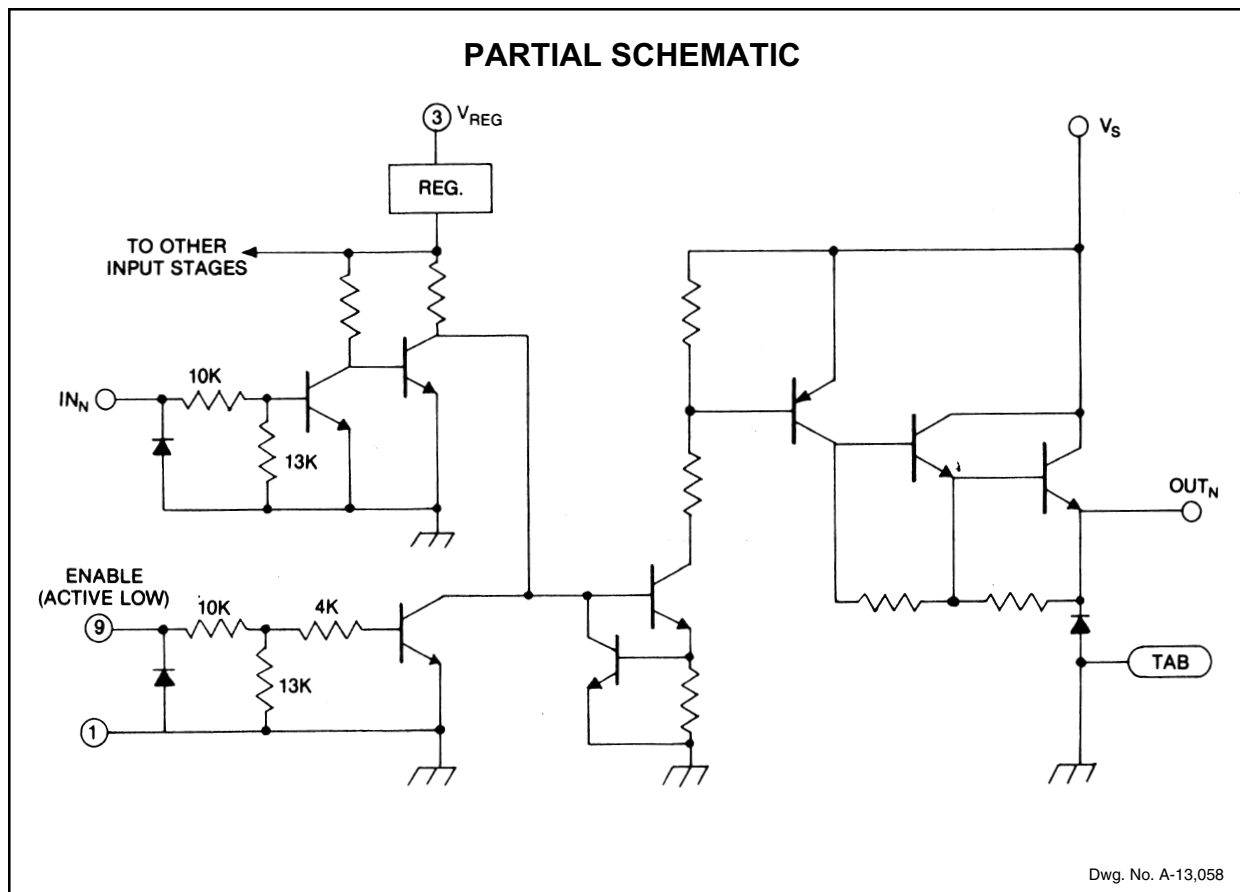

TRUTH TABLE

INPUT	ENABLE	OUTPUT
L	L	L
H	L	H
L	H	L
H	H	L

NOTE: Pin 3 must be connected to V_S for operation of input logic gates.

2944 QUAD HIGH-CURRENT, HIGH-VOLTAGE SOURCE DRIVER

ELECTRICAL CHARACTERISTICS at $T_A = +25^\circ\text{C}$, $T_J \leq +150^\circ\text{C}$, $V_S = 60\text{ V}$, $V_{\text{ENABLE}} = 0\text{ V}$
(unless otherwise noted).

Characteristic	Symbol	Test Conditions	Limits		
			Min.	Max.	Units
Supply Voltage Range	V_S		10	60	V
Output Leakage Current	I_{CEX}	$V_{\text{OUT}} = 0\text{ V}$, $V_{\text{ENABLE}} = 2.4\text{ V}$	—	50	μA
Output Sustaining Voltage	$V_{\text{CE(sus)}}$	$I_{\text{OUT}} = -4\text{ A}$, $L = 3\text{ mH}$	35	—	V
Output Saturation Voltage	$V_{\text{CE(SAT)}}$	$I_{\text{OUT}} = -1\text{ A}$, $V_{\text{IN}} = 2.4\text{ V}$	—	1.8	V
		$I_{\text{OUT}} = -4\text{ A}$, $V_{\text{IN}} = 2.4\text{ V}$	—	2.5	V
Input Voltage	Logic 1	$V_{\text{IN}(1)}$ or $V_{\text{ENABLE}(1)}$	2.0	—	V
	Logic 0	$V_{\text{IN}(0)}$ or $V_{\text{ENABLE}(0)}$	—	0.8	V
Input Current	Logic 1	$V_{\text{IN}(1)}$ or $V_{\text{ENABLE}(1)} = 2.4\text{ V}$	—	220	μA
		$V_{\text{IN}(1)}$ or $V_{\text{ENABLE}(1)} = 12\text{ V}$	—	1.5	mA
	Logic 0	$V_{\text{IN}(0)}$ or $V_{\text{ENABLE}(0)} = 0.8\text{ V}$	—	50	μA
Total Supply Current	I_S	All drivers on, All outputs open	—	25	mA
Clamp Diode Leakage Current	I_R	$V_R = 60\text{ V}$	—	50	μA
Clamp Diode Forward Voltage	V_F	$I_F = 4\text{ A}$	—	2.2	V
Turn-On Delay	t_{ON}	$0.5 E_{\text{in}}$ to $0.5 E_{\text{out}}$, $R_L = 15\ \Omega$	—	2.0	μs
Turn-Off Delay	t_{OFF}	$0.5 E_{\text{in}}$ to $0.5 E_{\text{out}}$, $R_L = 15\ \Omega$	—	10	μs

NOTE: Negative current is defined as coming out of (sourcing) the device being tested.

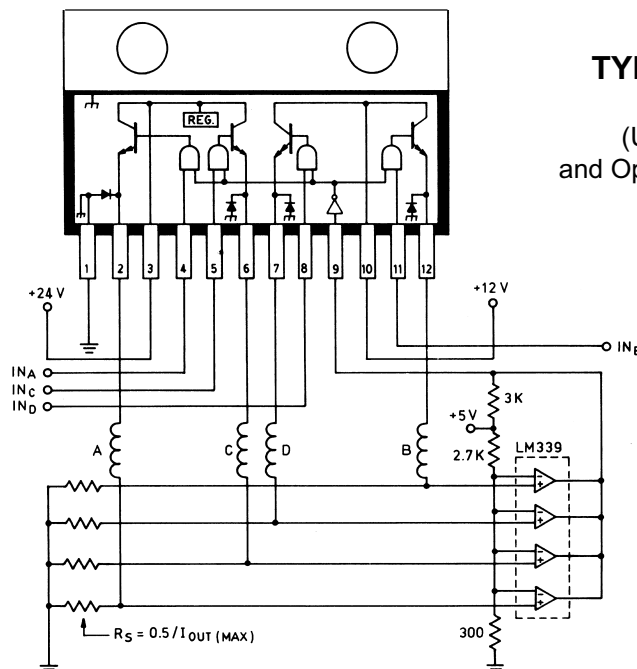

TYPICAL APPLICATION
QUAD RELAY DRIVE
(Using 2 Voltage Sources
and Optional PWM Current Limiting)

2944
QUAD HIGH-CURRENT,
HIGH-VOLTAGE
SOURCE DRIVER

Dimensions in Inches
 (controlling dimensions)

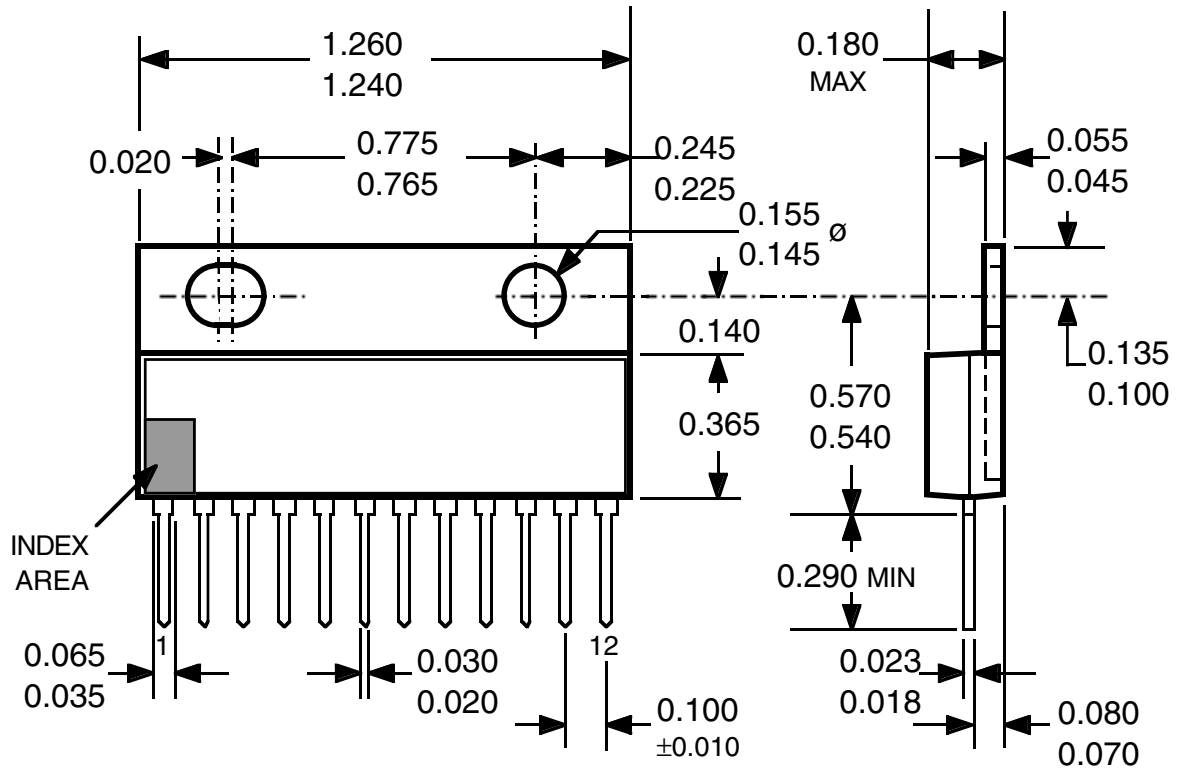

Dwg. MP-007 in

- NOTES: 1. Lead thickness is measured at seating plane or below.
 2. Lead spacing tolerance is non-cumulative.
 3. Exact body and lead configuration at vendor's option within limits shown.
 4. Lead gauge plane is 0.030" below seating plane.
 5. Supplied in standard sticks/tubes of 15 devices.

2944
QUAD HIGH-CURRENT,
HIGH-VOLTAGE
SOURCE DRIVER

Dimensions in Millimeters
(for reference only)

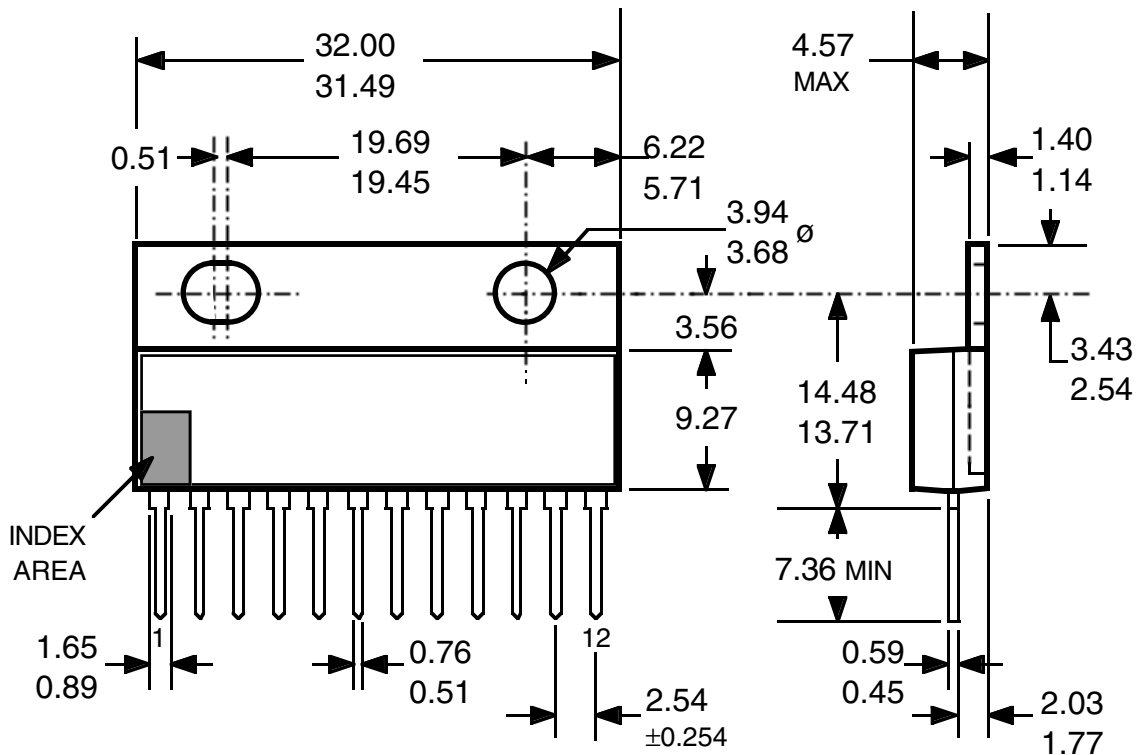

Dwg. MP-007 mm

- NOTES:
1. Lead thickness is measured at seating plane or below.
 2. Lead spacing tolerance is non-cumulative.
 3. Exact body and lead configuration at vendor's option within limits shown.
 4. Lead gauge plane is 0.762 mm below seating plane.
 5. Supplied in standard sticks/tubes of 15 devices.

2944
***QUAD HIGH-CURRENT,
HIGH-VOLTAGE
SOURCE DRIVER***

This page intentionally left blank



115 Northeast Cutoff, Box 15036
Worcester, Massachusetts 01615-0036 (508) 853-5000

2944
**QUAD HIGH-CURRENT,
HIGH-VOLTAGE
SOURCE DRIVER**

The products described here are manufactured under one or more U.S. patents or U.S. patents pending.

Allegro MicroSystems, Inc. reserves the right to make, from time to time, such departures from the detail specifications as may be required to permit improvements in the performance, reliability, or manufacturability of its products. Before placing an order, the user is cautioned to verify that the information being relied upon is current.

Allegro products are not authorized for use as critical components in life-support devices or systems without express written approval.

The information included herein is believed to be accurate and reliable. However, Allegro MicroSystems, Inc. assumes no responsibility for its use; nor for any infringement of patents or other rights of third parties which may result from its use.

2944
QUAD HIGH-CURRENT,
HIGH-VOLTAGE
SOURCE DRIVER

POWER SOURCE DRIVERS

IN ORDER OF 1) OUTPUT CURRENT, 2) OUTPUT VOLTAGE, 3) NUMBER OF DRIVERS

Output Ratings *			Features					Part Number †
mA	V	#	Serial Input	Latched Drivers	Diode Clamp	Saturated Outputs	Internal Protection	
-25	60	8	–	X	–	–	–	5815
	60	10	X	X	active pull-down	–	–	5810-F and 6809/10
	60	12	X	X	active pull-down	–	–	5811 and 6811
	60	20	X	X	active pull-down	–	–	5812-F and 6812
	60	32	X	X	active pull-down	–	–	5818-F and 6818
	85	8	–	–	–	–	–	6118
-120	-25	8	–	–	X	X	–	2585
	30	8	–	–	X	X	–	2985
	50	8	X	X	X	X	–	5895
-350	35	8	–	–	X	–	X	2987
	50	8	–	–	X	–	–	2981 and 2982
	50	8	X	X	X	–	–	5891
	-50	8	–	–	X	–	–	2580
	80	8	–	–	X	–	–	2983 and 2984
	80	8	X	X	X	–	–	5890
	-80	8	–	–	X	–	–	2588
-500	6	1	–	–	–	MOSFET	X	2525 and 2535
	6	2	–	–	–	MOSFET	X	2526 and 2536
-4000	60	4	–	–	X	–	–	2944

* Current is maximum specified test condition, voltage is maximum rating. See specification for sustaining voltage limits or over-current protection voltage limits.

† Complete part number includes additional characters to indicate operating temperature range and package style.



115 Northeast Cutoff, Box 15036
Worcester, Massachusetts 01615-0036 (508) 853-5000