

**MLL746A,-1 thru MLL759A,-1
and
MLL4370A,-1 thru MLL4372A,-1**
±1% and ±2% Versions
"C" and "D" Available

Features

- Leadless Package For Surface Mount Technology
- Ideal For High Density Mounting
- Voltage Range 2.4 To 12 Volts
- Hermetically Sealed, Double Slug Glass Construction
- Metallurgically Bonded Construction Available as Dash One.
- Available in JAN, JTX, JTXV-1 To Mil-PRF-19500/127 (UR-1 Suffix)

Maximum Ratings

500 mW DC Power Dissipation (See Power Derating Curve In Figure 1)
-55°C to +175°C Operating and Storage Junction Temperature

Application

This surface mountable zener diode series is similar to the 1N746 thru 1N759 in the DO-35 equivalent package except that it meets the new JEDEC surface mount outline DO-213AA. It is an ideal selection for applications of high density and low parasitic requirements. Due to its glass hermetic qualities, it may also be considered for high reliability applications.

Electrical Characteristics @25°C

MICROSEMI PART NUMBER	NOMINAL ZENER VOLTAGE V _Z @ I _{ZT} (NOTE 1)	ZENER TEST CURRENT I _{ZT}	MAXIMUM ZENER IMPEDANC E Z _{ZT} @ I _{ZT} (NOTE 2)	MAXIMUM REVERSE CURRENT @ V _R = 1 VOLT		MAXIMUM ZENER CURRENT I _{ZM} (NOTE 4)	TYPICAL TEMP COEFF. OF ZENER VOLTAGE ΔV _Z /ΔT
				@25°C	@ +150°C		
**	VOLTS	mA	OHMS	μA	μA	mA	%/°C
MLL4370A	2.4	20	30	100	200	150	-.085
MLL4371A	2.7	20	30	75	150	135	-.080
MLL4372A	3.0	20	29	50	100	120	-.075
MLL746A	3.3	20	28	10	30	110	-.066
MLL747A	3.6	20	24	10	30	100	-.058
MLL748A	3.9	20	23	10	30	95	-.046
MLL749A	4.3	20	22	2	30	85	-.033
MLL750A	4.7	20	19	2	30	75	-.015
MLL751A	5.1	20	17	1	20	70	±0.010
MLL752A	5.6	20	11	1	20	65	+0.030
MLL753A	6.2	20	7	.1	20	60	+0.049
MLL754A	6.8	20	5	.1	20	55	+0.053
MLL755A	7.5	20	6	.1	20	50	+0.057
MLL756A	8.2	20	8	.1	20	45	+0.060
MLL757A	9.1	20	10	.1	20	40	+0.061
MLL758A	10.0	20	17	.1	20	35	+0.062
MLL759A	12.0	20	30	.1	20	30	+0.062

Note 1 Voltage measurements to be performed 20 seconds after application of dc test current.

Note 2 Zener impedance derived by superimposing on I_{ZT} at 60 Hz rms ac current equal to 10% I_{ZT} (2 mA ac).

Note 3 Allowance has been made for the increase in V_Z due to Z_Z and for the increase in junction temperature as the unit approaches thermal equilibrium at the power dissipation at 500 mW.

** Ordering Information:

- 1) Commercial: MLL746A thru MLL759A or MLL746A-1 thru MLL759A-1
MLL4370A thru MLL4372A or MLL4370A-1 thru MLL4372A-1
- 2) Military: JAN, JANTX, or JANTXV 1Nxxxx UR-1
- 3) Tight tolerance "C" suffix = ±2%, "D" suffix = ±1%

LEADLESS GLASS ZENER DIODE SURFACE MOUNT

Package Dimensions In Inches

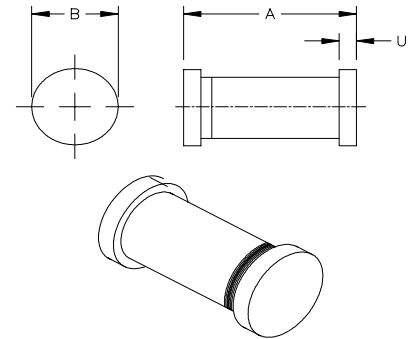

DIM	MILLIMETERS		INCHES	
	MIN	MAX	MIN	MAX
A	3.30	3.70	.130	.146
B	1.60	1.70	.063	.067
U	0.41	0.55	.016	.022

DO-213AA

Mechanical Characteristics

Case: Hermetically sealed glass with solder contact tabs at each end.

Finish: All external surfaces are corrosion resistant, readily solderable.

Polarity: Banded end is cathode.

Thermal Resistance: 100°C/Watt Maximum junction to end caps for "-1" construction and 150°C/W maximum junction to end caps for commercial.

Mounting Position: Any

Weight: 0.04 gm

**MLL746A,-1 thru MLL759A,-1
and
MLL4370A,-1 thru MLL4372A,-1
±1% and ±2% Versions
“C” and “D” Available**

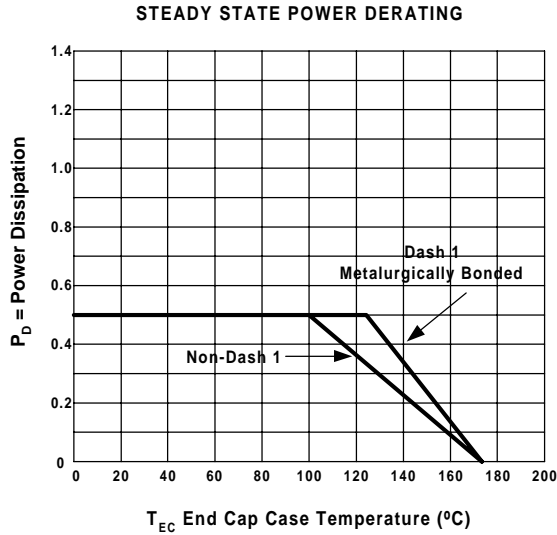

FIGURE 1

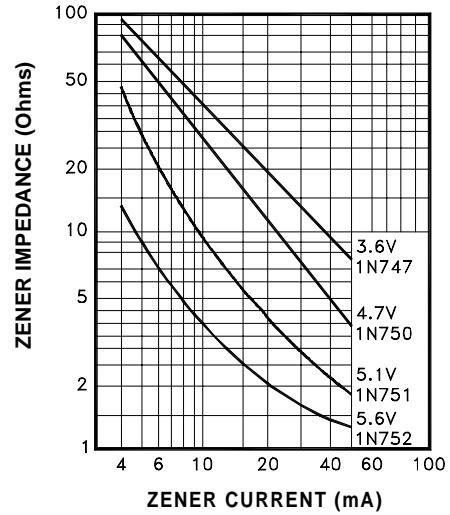

FIGURE 2
ZENER IMPEDANCE VS ZENER CURRENT
(TYPICAL)

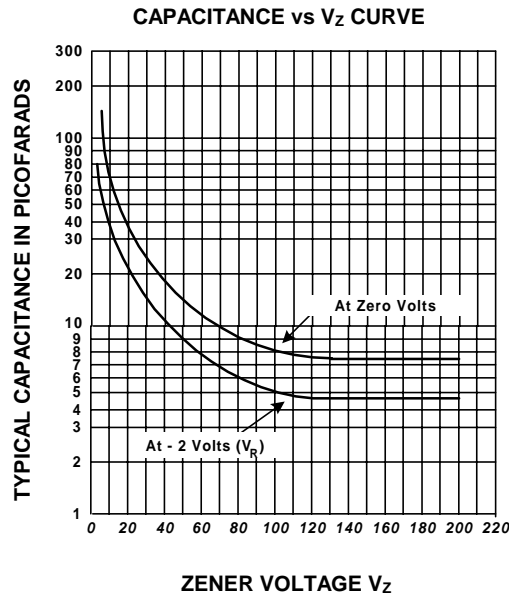

FIGURE 3
CAPACITANCE VS ZENER VOLTAGE
(TYPICAL)