

**5V Input, 3A Output Current**  
**+3.3V, +2.5V +1.8V, +1.5V Output**  
**Switching Regulator**  
**Three Terminal Package**

**FEATURES**

- High Efficiency
- Internal Short Circuit Protection
- Small Footprint
- High Power Density- 60W/in.<sup>3</sup>

**APPLICATIONS**

- High Power 5V to 3.3V Regulation
- Low Voltage Battery regulation
- Embedded Processor Power
- General Purpose Low Voltage Logic Supply
- FPGA Power

**DESCRIPTION**

The OM955X series of Switching Regulators are designed for pin compatibility with standard 3-Pin linear regulators. They are well suited for on-board, non- isolated power applications where efficient point- of- load regulation is needed. The package is designed using Chip- on – Board technology to reduce cost and maintain power density. These units will typically not require any additional components in your application due to capacitance provided internal to the package.

**MAXIMUM RATINGS @ Ta=25° C (unless otherwise specified)**

Parameter	Value	Conditions
Input Voltage	8V	
Output Current	4A	Short Circuit
Power Dissipation	1.8W	Short Circuit
Output Power	10W	Short Circuit
Lead Temp.	230°C	< 1 min.

**CONFIGURATION CHART**

MODEL	OUTPUT VOLTAGE	TEMPERATURE RANGE	MAX. OUTPUT CURRENT
OM9551SP	3.3V	-25 to +85°C	3.0A
OM9552SP	2.5V	-25 to +85°C	3.0A
OM9553SP	1.8V	-25 to +85°C	3.0A
OM9554SP	1.5V	-25 to +85°C	3.0A

**PERFORMANCE CHARACTERISTICS (Ta= 25°C)****INPUT**

Parameter	Symbol	Test Conditions	MIN	MAX	Units
Line Regulation	Rline	4.5V ≤ Vin ≤ 5.5V	-0.5	+0.5	%
Input Voltage Range	Vin		4.5	7.0	V
Input Filtering <sup>1</sup>				22	uF

**OUTPUT**

Parameter	Symbol	Test Conditions	MIN	TYP	MAX	Units
Power	Po	Vo= 3.3V			10	W
Vout Accuracy	ΔVo	Vo= 3.3V, +2.5V, +1.5V+1.8V		0.8	1.0	%
Vout Regulation	Vreg	Vin= 5V, 0.1 ≤ Io ≤ 3A		0.3	0.1	%
Output Ripple	Vη	Vin= 5V, Io= 3.0A		80	100	mV(p-p)
Current Limiting	Ilim	Vin= 5V		4.0		A
Efficiency	η	Vin=5V, Io=3A, Vo=+3.3V		88		%
Efficiency	η	Vin=5V, Io=3A, Vo=+2.5V		87		%
Efficiency	η	Vin=5V, Io=3A, Vo=+1.8V		86		%
Efficiency	η	Vin=5V, Io=3A, Vo=+1.5V		85		%
Min. Load Current	Ii(min)		0.1			A
Output Filter Capacitance <sup>1</sup>	Co	All Models		330		uF

**DYNAMIC**

Parameter	Test Conditions	MIN	TYP	MAX	Units
Transient Response	50% load step ΔVout		40	200	μS mV
Frequency	0 to 85°C	175	200	225	KHz

**ENVIRONMENTAL**

Parameter	MODEL	MIN	MAX	Units
Operating Temperature	OM9551SP, OM9552SP, OM9553SP, OM9554SP	-25	85	°C
Storage Temp.		-40	125	°C
Flammability			UL94V0	

<sup>1</sup> Included in the package

**Typical Performance Characteristics (Ta= 25°C)**  
**Vo= +3.3V**

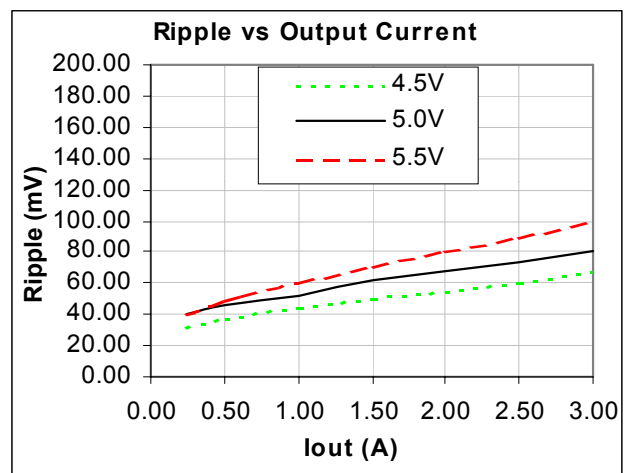
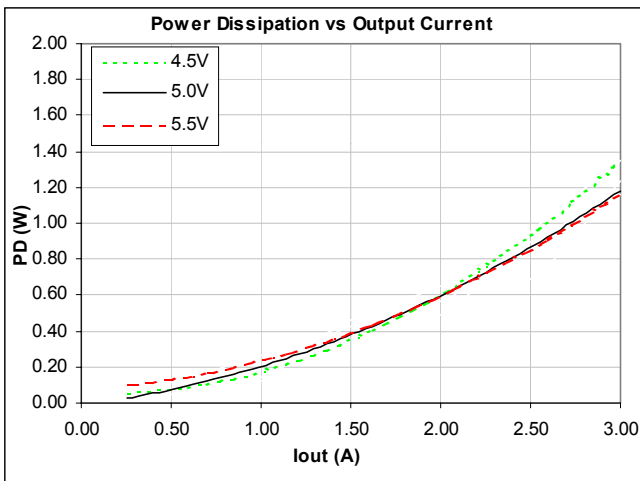
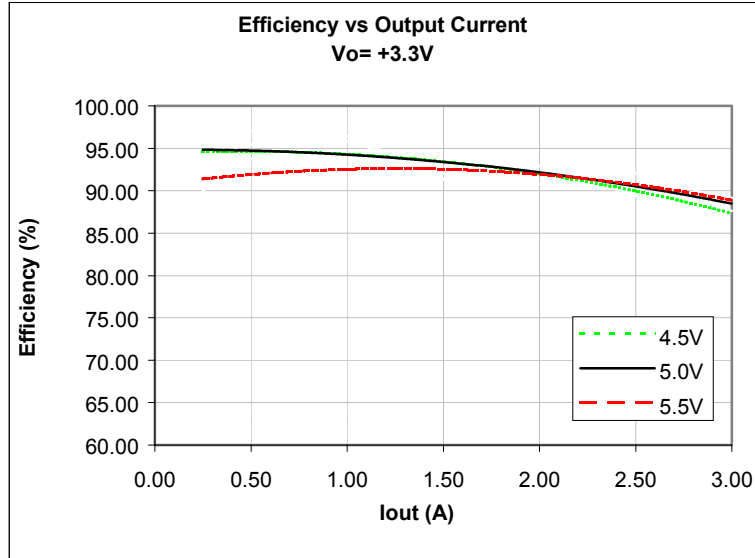

### MECHANICAL OUTLINE

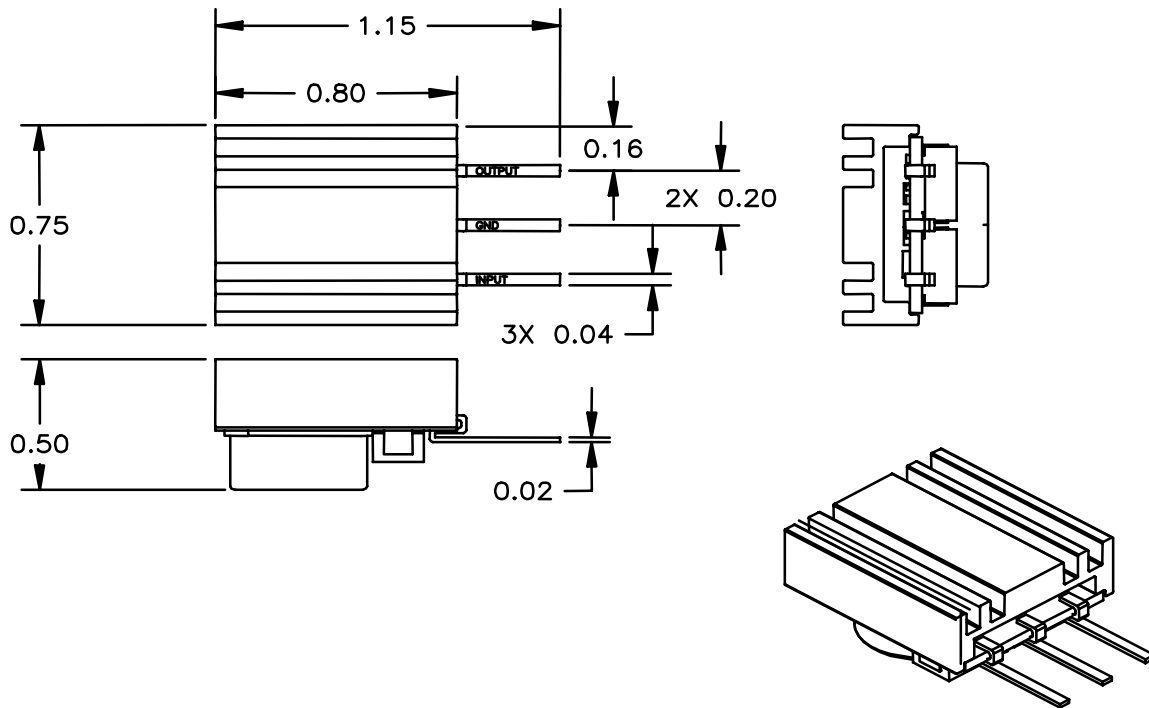

### Package Pinout

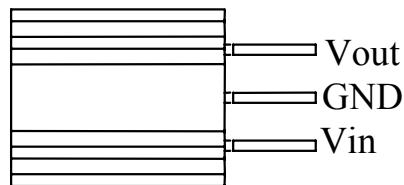

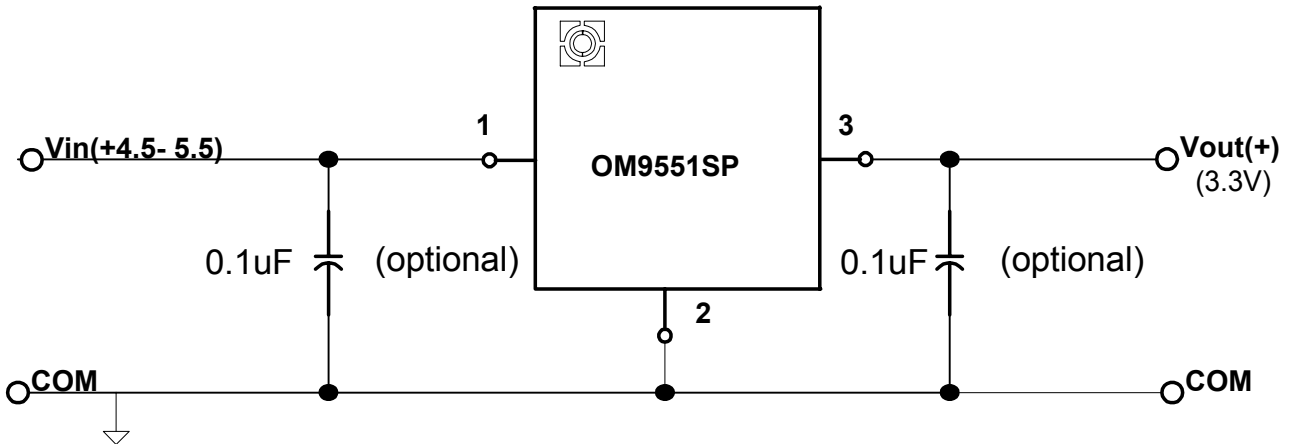
APPLICATION CIRCUIT

Internal to the package is a 22uF input capacitor and a 330uF output capacitor. The Omnirel process allows sufficient space allocation to include all components necessary to complete the basic regulation design. The additional by-pass capacitors are suggested if an improvement in switching noise becomes necessary.