

DSP-BASED MOTOR CONTROLLER

FEATURES / BENEFITS

- Embedded Motor Control DSP improves system integration and flexibility
- 15A average phase current with 325V maximum bus voltage
- Hall Effect sensor based or sensorless control for improved reliability
- Logic supplies (+15V/+5V) generated onboard, eliminating external parts
- Serial port for isolated RS-232 interface allows system level control
- Direction and Velocity control
- Rugged plastic module for high reliability applications
- Low impedance bus terminal construction

APPLICATIONS

- Fans
- Pumps
- Compressors
- Fin Actuators
- Braking Systems

DESCRIPTION

The OM9391SP is a DSP-based motor controller for three-phase AC Motors, such as the Permanent Magnet Synchronous Motor (PMSM) or the AC Induction Motor (ACIM). The controller is designed to improve system integration, efficiency, flexibility, and reliability while reducing the overall system cost. The OM9391SP can be configured for trapezoidal commutation via Hall effect sensor feedback. In this configuration, the Hall effect sensor outputs provide discrete absolute rotor position for commutation. The Hall effect sensor outputs are fed into the control port, level shifted onboard from 15V to 5V, then fed directly into the DSP. Based on this information, velocity is determined. Alternatively, the OM9391SP can be configured for sinusoidal or trapezoidal commutation via sensorless control. Consult the factory for details.

The OM9391SP requires a single ended 28V supply for logic and up to 270V for motor bus. The logic voltage supplies (15V and 5V) are derived onboard from the 28V supply. The OM9391SP will accommodate either an analog or digital command input. For the latter, a serial port is provided onboard to interface with an isolated RS-232 communications port. The OM9391SP provides direction control as well as current limit for over-current protection.

The OM9391SP is a complete motor control solution housed in a rugged plastic module designed for high reliability applications. The assembly process includes chip-on-IMS (Insulated Metal Substrate) technology for the driver and power stages to maximize the power density and surface mount technology for the control stage. This combination of chip-on-IMS and surface mount technologies and rugged plastic package provides a low cost, high performance motor control solution for high reliability applications including fans, pumps, compressors, fin actuators and braking systems.

PRELIMINARY

OM9391SP

SIMPLIFIED BLOCK DIAGRAM

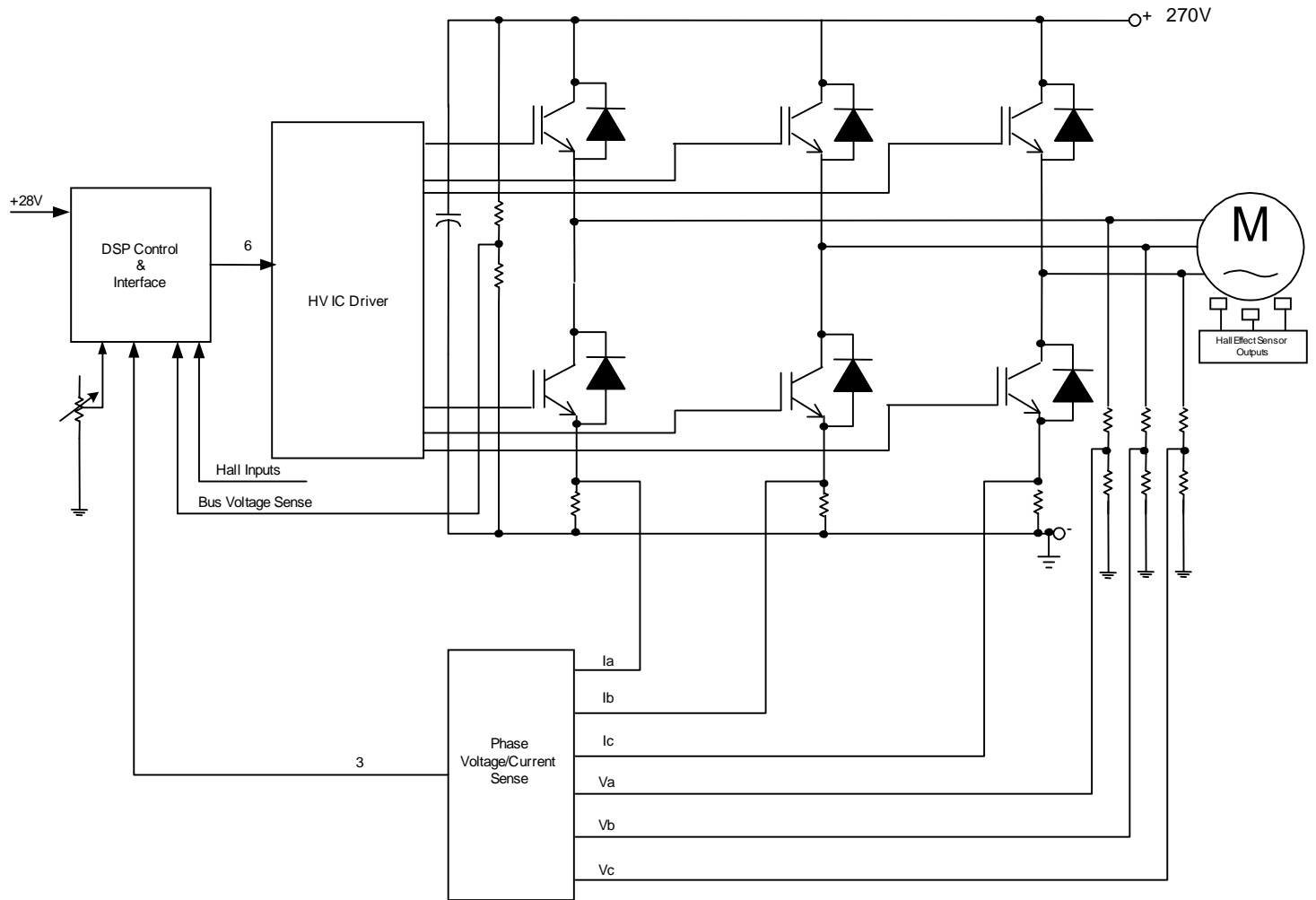

Rev 01 5/29/00

2



205 Crawford Street • Leominster MA 01453 • Phone: 978 534 5776 • Fax: 978 537 4246 • www.omnirel.com

PRELIMINARY

OM9391SP

ABSOLUTE MAXIMUM RATINGS

Motor Supply Voltage, $V_{m \text{ max}}$	325Vdc
Average Phase Output Current, $I_o @ T_A = +25^\circ \text{C}$	15A dc
Logic Input Voltage (Note 1)	5.25V
Operating Temperature Range.....	-40°C to $+85^\circ \text{C}$
Power Switch Junction-to-Case Thermal Resistance, R_{qjc}	0.70°C/W

RECOMMENDED OPERATING CONDITIONS ($T_A = 25^\circ \text{C}$)

Motor Power Supply Voltage, V_m	+270 Vdc
Average Phase Output Current, I_o	10 A

Note 1: Logic Inputs: Direction, Speed In, Reset

PRELIMINARY

OM9391SP

ELECTRICAL CHARACTERISTICS (TA = 25° C)

Parameter	Symbol	Conditions	MIN	TYP.	MAX.	Units
Power Output Section						
IGBT Leakage Current	I _{ces}	V _{ce} = 600 Vdc V _{ge} = 0V			300	μA
IGBT c-e Saturation Voltage	V _{ce(sat)} V _{ge} = 15V	I _c = 50A dc			3.2	V
Diode Leakage Current	I _r	V _r = 600Vdc			100	μA
Diode Forward Voltage	V _f	I _f = 37A			1.7	V
Diode Reverse Recovery Time	t _{rr}	I _o = 1A, di/dt = -100A/μsec V _r = 30V			50	nsec
Logic Input Section						
Low Level Input Voltage	V _{IL}				0.8	V
High Level Input Voltage	V _{IH}		2.0			V
Command Input Section						
Speed In Voltage Range	V _{CM}		0		5	V

PINOUT

PIN #	NAME
	Direction
	Speed In
	Logic_Gnd
	Reset
	DRIB
	DT1
	Logic_Gnd
	PWMTRIP
	Logic_Gnd
	TFSI
	+28V
	Hall_1
	Hall_2
	Hall_3
	+15V
	Logic_Gnd
	AUX PWM
	RFSI
	Logic_Gnd
	Reset_RS232
	Voltage Bus
	Bus Return
	Phase A
	Phase B
	Phase C

Rev 01 5/29/00

4



205 Crawford Street • Leominster MA 01453 • Phone: 978 534 5776 • Fax: 978 537 4246 • www.omnirel.com

PRELIMINARY

OM9391SP

PIN DESCRIPTIONS / FUNCTIONALITY

PWMTRIP - A logic low at this input places all six PWM outputs in the **OFF** state. Otherwise, this pin is pulled up to +5V onboard.

+28V - This supply is required to generate logic supplies (+15V / +5V) onboard.

Direction - This logic input is used to select the motor direction.

Speed In - This input is the analog command input to the OM9391SP.

Reset - A logic low at this input initiates a complete hardware reset of the DSP.

AUX_PWM - This output is an auxiliary PWM output.

Logic_Gnd - This pin provides the reference point for the command section.

TFS1 - This pin is left open during normal operation. It is dedicated for engineering purposes only.

RFS1 - This pin is left open during normal operation. It is dedicated for engineering purposes only.

Logic_Gnd - This pin provides the reference point for the +15V supply.

Reset_RS-232 - A logic low at this input initiates a complete hardware reset of the DSP. This reset is provided through the RS-232 interface.

DR1B - This pin is dedicated as the data receive pin for the RS-232 interface. Note that an isolated RS-232 interface is offered with the OM9391SP. Consult the factory for more information.

Logic_Gnd - This pin provides the reference point for the RS-232 interface.

DT1 - This pin is dedicated as the data transmit pin for the RS-232 interface. Note that an isolated RS-232 interface is offered with the OM9391SP. Consult the factory for more information.

+15V - This supply is provided for the Hall effect sensor bias.

Hall_1 - This pin is dedicated to the phase A Hall effect sensor output.

Hall_2 - This pin is dedicated to the phase B Hall effect sensor output.

Hall_3 - This pin is dedicated to the phase C Hall effect sensor output.

Logic_Gnd - These pins provide the reference point for the +28V supply.

Voltage Bus - This terminal is connected to the positive terminal of the 270V supply.

Bus Return - This terminal is connected to the negative terminal of the 270V supply.

Phase A - This terminal is connected to the phase A motor lead.

Phase B - This terminal is connected to the phase B motor lead.

Phase C - This terminal is connected to the phase C motor lead.



PRELIMINARY

OM9391SP

MECHANICAL SPECIFICATIONS

- Overall Dimensions
(L) 4.25 in. x (W) .48 in. x (H) TBD
- Weight: TBD

