

AS3645

1000/720mA Ultra Small High efficient single/dual LED Flash Driver with Safety Features

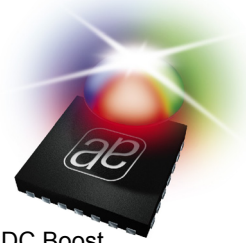

1 General Description

The AS3645 is an inductive high efficient DCDC step up converter with two current sources. The DCDC step up converter operates at a fixed frequency of 2MHz and includes soft startup to allow easy integration into noise sensitive RF systems. The two current sources (one for driving one or two flash LEDs and one for the indicator LED) can operate in flash / torch / assist (=video) light / indicator modes. If a two flash LEDs configuration is used, the LEDs are connected in series. Therefore identical current is guaranteed.

The AS3645 includes flash timeout, overvoltage, over-temperature, undervoltage and LED short circuit protection functions.

The AS3645 can be controlled either with parallel interface mode to allow simple integration. Alternatively it can be controlled by I²C mode to allow a more sophisticated control of all settings like currents and timings. The interface is selected by a dedicated pin (I2C/EN).

The AS3645 is available in a space-saving WL-CSP package measuring only 2x1.6mm and operates over the -30°C to +85°C temperature range.

2 Key Features

- High efficiency 2MHz fixed frequency DCDC Boost converter with soft start allows small coils
 - Stable even in coil current limit
- High Flash LED(s) current (720mA for single flash LED, 1000mA (2x500mA) for dual flash LED)
- Separate Indicator LED output
- Flash LED(s) cathode connected to ground: Improved thermal performance (ground = heat sink) Simplified PCB layout
- Flash, Torch, Assist and Indicator Mode
- Protection functions:
 - Automatic Flash Timeout timer to protect the LED(s)
 - Overvoltage and undervoltage Protection
 - Overtemperature Protection
 - LED(s) short circuit protection
- Dual Interface selectable by pin (parallel interface mode and I²C mode)
- Available in tiny WL-CSP Packages
 - 3x4 balls 0.5mm pitch, 2x1.6mm package size

3 Applications

Flash/Torch for mobile phones, digital cameras and PDA

Figure 1. Typical Operating Circuit

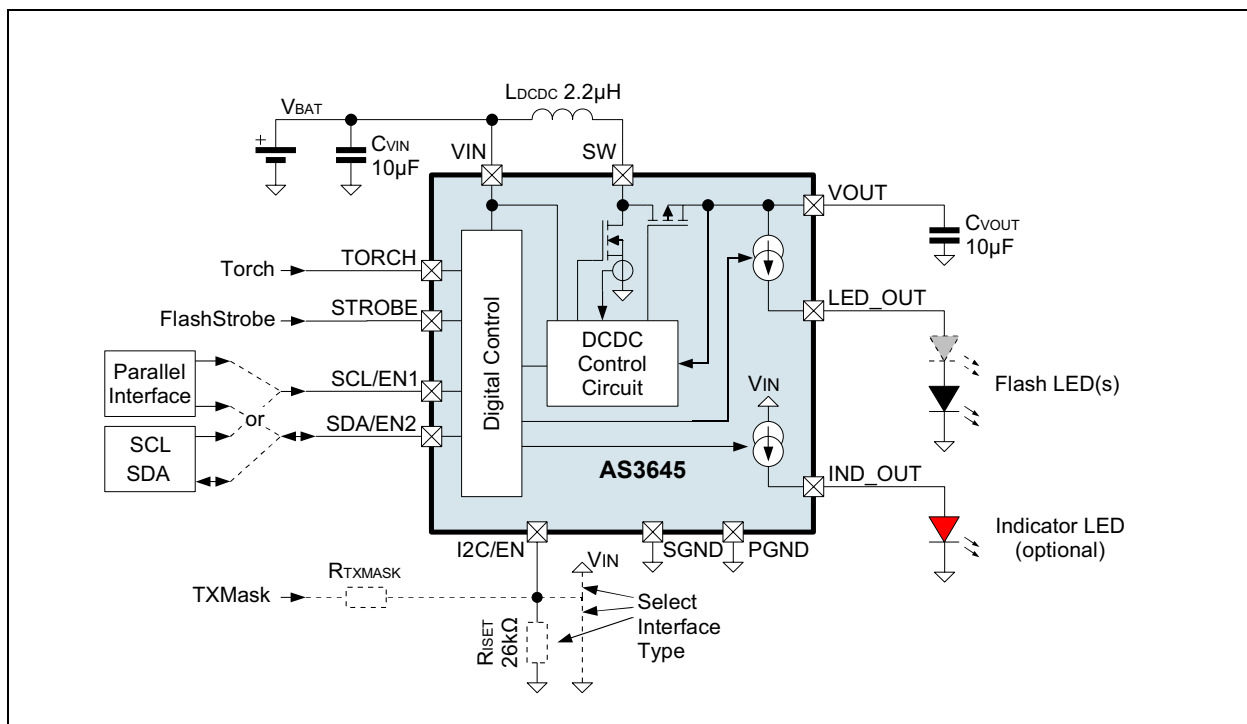

4 Pinout

Pin Assignment

Figure 2. Pin Assignments (Top View)

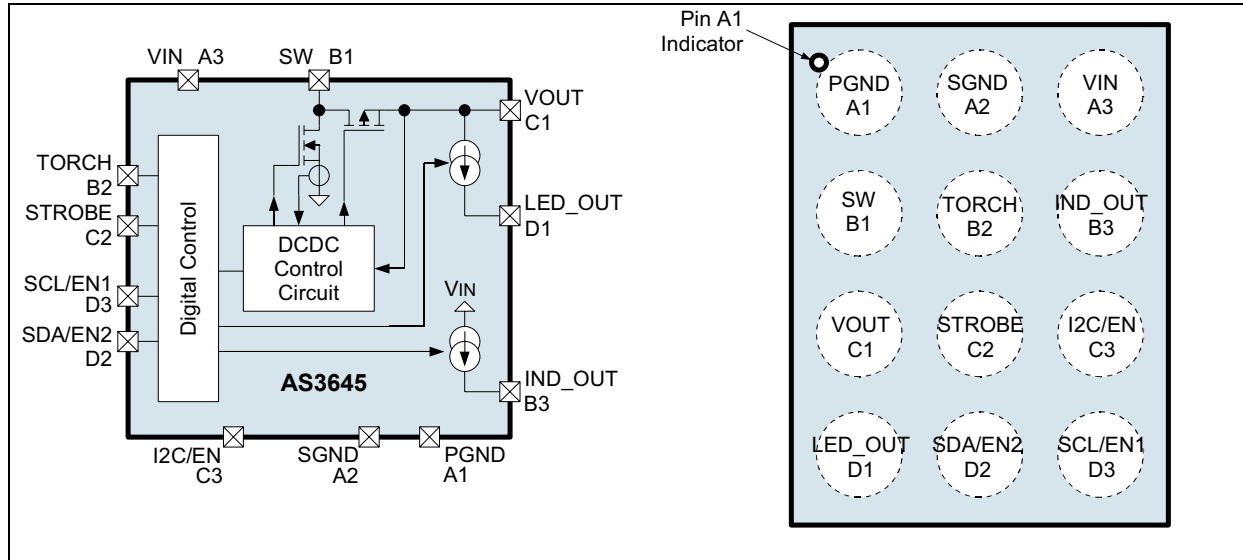

Pin Description

Table 1. Pin Description for AS3645

Pin Number	Pin Name	Description
A1	PGND	Power ground - connect to ground (GND)
A2	SGND	Signal ground - connect to ground (GND)
A3	VIN	Positive supply voltage input - connect to supply and make a short connection to input capacitor C _{VIN} and to coil L _{DCDC}
B1	SW	DCDC converter switching node - make a short connection to the coil L _{DCDC}
B2	TORCH	Torch control digital input with pulldown - enables torch function
B3	IND_OUT	Indicator LED current source output
C1	VOUT	DCDC converter output capacitor - make a short connection to C _{VOUT}
C2	STROBE	I ² C mode: Digital input with pulldown to control strobe time for flash function ¹ parallel interface mode: Open drain output to identify single/dual flash LED
C3	I2C/EN	Control pin for the operating mode of the AS3645: <ol style="list-style-type: none"> set to high (e.g. VIN) for I²C mode set to low (GND) for parallel interface mode with fixed output currents connect a current set resistor to GND (R_{ISET}) for parallel interface mode with adjustable output currents
D1	LED_OUT	Flash LED current source output
D2	SDA/EN2	serial data input/output for I ² C mode (needs external pullup resistor); EN2 input with pulldown for parallel interface mode
D3	SCL/EN1	serial clock input in I ² C mode EN1 input with pulldown in parallel interface mode

1. Application Note: The pin STROBE is usually connected to the camera processor.

5 Absolute Maximum Ratings

Stresses beyond those listed in [Table 2](#) may cause permanent damage to the device. These are stress ratings only, and functional operation of the device at these or any other conditions beyond those indicated in [Table 3, "Electrical Characteristics," on page 4](#) is not implied. Exposure to absolute maximum rating conditions for extended periods may affect device reliability.

Table 2. Absolute Maximum Ratings

Parameter	Min	Max	Units	Comments
VIN to GND	-0.3	+7.0	V	
TORCH, STROBE, SCL/EN1, SDA/EN2, I2C/EN, IND_OUT to GND	-0.3	VIN + 0.3	V	
SW, VOUT, LED_OUT to GND	-0.3	+18.0	V	
VOUT or SW to VIN	-0.3		V	Note: Diode between VOUT and SW
SGND, PGND to GND	0.0	0.0	V	Connect SGND and PGND to GND directly below the pad (short connection recommended)
Input Pin Current without causing latchup	-100	+100 +IIN	mA	Norm: EIA/JESD78
Continuous Power Dissipation (TA = +70°C)				
Continuous power dissipation		1020	mW	PT ¹
Continuous power dissipation derating factor		14.7	mW/°C	PDERATE ²
Electrostatic Discharge				
ESD HBM		±2000	V	Norm: MIL 883 E Method 3015
ESD CDM		±500	V	Norm: JEDEC JESD 22-C101C
ESD MM		±100	V	Norm: JEDEC JESD 22-A115-A level A
Temperature Ranges and Storage Conditions				
Junction Temperature		+150	°C	Internally limited (overtemperature protection)
Storage Temperature Range	-55	+125	°C	
Humidity	5	85	%	Non condensing
Body Temperature during Soldering		+260	°C	according to IPC/JEDEC J-STD-020C

1. Depending on actual PCB layout and PCB used; for peak power dissipation during flashing see document 'AS3645 Thermal Measurements'
2. PDERATE derating factor changes the total continuous power dissipation (PT) if the ambient temperature is not 70°C. Therefore for e.g. TAMB=85°C calculate PT at 85°C = PT - PDERATE * (85°C - 70°C)

6 Electrical Characteristics

$V_{VIN} = +2.7V$ to $+5.5V$, $T_{AMB} = -30^{\circ}C$ to $+85^{\circ}C$, unless otherwise specified. Typical values are at $V_{VIN} = +3.6V$, $T_{AMB} = +25^{\circ}C$, unless otherwise specified.

Table 3. Electrical Characteristics

Symbol	Parameter	Condition	Min	Typ	Max	Unit
General Operating Conditions						
V_{VIN}	Supply Voltage		2.7	3.6	4.8	V
$V_{VINREDUCE_D_FUNC}$	Supply Voltage	AS3645 functionally working, but not all parameters fulfilled	2.5		2.7	V
$I_{SHUTDOWN}$	Shutdown Current	parallel interface mode, TORCH=L, SCL/EN1=L, SDA/EN2=L, $V_{VIN}<3.7V$		0.5	1.0	μA
I_{STANBY}	Standby Current	I^2C mode, interface active, TORCH=L, $V_{VIN}<3.7V$		0.5	10	μA
T_{AMB}	Operating Temperature		-30	25	85	$^{\circ}C$
DCDC Step Up Converter						
V_{VOUT}	DCDC Boost output Voltage (pin VOUT)	Single or Dual LED operation	2.8		8.6	V
Eta	Efficiency	Dual LED operation, $I_{LED_OUT}=300mA$ to $400mA$, $V_{VOUT}=7.2V$		85		%
fCLK	Operating Frequency	All internal timings are derived from this oscillator	-7.5%	2.0	+7.5%	MHz
Current Sources						
I_{LED_OUT}	LED_OUT current source output	Single LED operation	20.0		720	mA
		Dual LED operation	2x 20.0		2x500	mA
$I_{LED_OUT\Delta}$	LED_OUT current source accuracy	$I_{LED_OUT}<320mA$ or using external current set resistor R_{ISET}	-10		+10	%
		$I_{LED_OUT}\geq 320mA$, I^2C mode or parallel interface mode with fixed output currents	-5		+5	%
$I_{LED_OUT_RAMP}$	LED_OUT ramp time	Ramp-up During startup	0.6		1.25	ms
		Ramp-down after AS3645 is disabled by interface	0.2		0.7	ms
$I_{LED_OUT_RIPPLE}$	LED_OUT current ripple	$I_{LED_OUT} = 320mA$		10		mAPP
V_{ILED_COMP}	LED_OUT current source voltage compliance	Minimum voltage between pin VOUT and LED_OUT for operation of the current source		300	350	mV
I_{LED_DET}	Single/Dual LED Detection	Current used for single/dual LED detection		80		mA
I_{IND_OUT}	IND_OUT current source	$V_{VIN} > 2.7V$, indicator LED forward voltage between 1.3V and 2.4V (e.g. use red LED)	2.5		10	mA
$I_{IND_OUT\Delta}$	IND_OUT current source accuracy		-20		+20	%
parallel interface mode with adjustable output currents using R_{ISET} current setting (see page 13)						
AS3645B only						
R_{ISET}	External resistor	Using the typical resistor R_{ISET} (26k Ω) all current are identical to the parallel interface mode with fixed current settings (pin I2C/EN tied to ground)	20	26	46.2	k Ω

Table 3. Electrical Characteristics (Continued)

Symbol	Parameter	Condition	Min	Typ	Max	Unit	
IRISETMAX	Maximum Current through RISET	see Device Startup and Operating Mode selection on page 12		200		µA	
VISET	Voltage on RISET	Voltage on RISET in this mode		1.3		V	
VTXMASK	Voltage on pin I2C/EN	Maximum voltage on pin I2C/EN in shutdown if TXMASK function is used			0.5	V	
Protection and Fault Detection Functions (see page 10)							
VVOUTMAX	VVOUT overvoltage protection	DCDC Converter Overvoltage Protection	9.0	9.5	10.0	V	
ILIMIT	Current Limit ¹ for coil LDCDC (Pin SW) measured at 75% PWM duty cycle ² maximum 40000s lifetime operation in overcurrent limit	coil_peak=00b	1.125	1.25	1.375	A	
		coil_peak=01b	1.35	1.5	1.65		
		default value for I ² C mode; value for parallel interface mode	coil_peak (see page 23)=10b	1.575	1.75		1.925
		coil_peak=11b	1.7	2.0	2.2		
VLEDSHORT	Flash LED short circuit detection voltage	Voltage measured on pin LED_OUT		1.45	1.65	V	
VINDSHORT	Indicator LED short circuit detection voltage	Voltage measured on pin IND_OUT		0.7	1.2	V	
IIND_OUT_OPEN	IND_OUT current open detection	Detection threshold for open indicator detection on pin IND_OUT		45		% of IIND_OUT	
TOVTEMP	Overtemperature Protection	Junction temperature		144		°C	
TOVTEMPHYST	Overtemperature Hysteresis			5		°C	
tFLASHTIMEOUT	Flash Timeout Timer	Can be adjusted in I ² C mode with register flash_timeout (page 20)	-7.5%	850	+7.5%	ms	
VUVLO	Undervoltage Lockout	Falling VVIN	2.275	2.4	2.5	V	
		Rising VVIN	VUVLO+0.05	VUVLO+0.1	VUVLO+0.15	V	
VLED_DET	Single/Dual LED Detection Threshold	default value for I ² C mode; value for parallel interface mode	vref_offset (see page 20)=00	4.15	4.35	4.55	V
			vref_offset=01	4.45	4.65	4.85	V
			vref_offset=10	3.85	4.05	4.25	V
			vref_offset=11	4.75	4.95	5.15	V
Digital Interface							
VIH	High Level Input Voltage	Pins TORCH, STROBE, SCL/EN1, SDA/EN2, I2C/EN ³	1.26		VVIN	V	
VIL	Low Level Input Voltage		0.0		0.54	V	
VOL	Low Level Output Voltage	Pin STROBE in parallel interface mode, pins SCL/EN1 and SDA/EN2 in I ² C mode. IOL=4mA			0.15	V	

Table 3. Electrical Characteristics (Continued)

Symbol	Parameter	Condition	Min	Typ	Max	Unit
IPD	Pulldown current to GND ⁴	Pins TORCH, STROBE in all modes and pins SCL/EN1 and SDA/EN2 in parallel interface mode		5		μA
IRESDET_I2C/EN	Resistor detection current threshold ⁵	Pin I2C/EN only during detection of external resistor RISET		200		μA
tDEBTORCH	TORCH debounce time		6.3	9	11.7	ms
tI2C/ENDEB	Pin I2C/EN timing	time from SCL/EN1=0 and SDA_EN2=0 to I2C/EN = 0			5	μs
		time from I2C/EN = 1 to accept I ² C start condition	250			μs
I²C mode timings - see Figure 3 on page 7						
fSCLK	SCL_EN1 Clock Frequency		0		400	kHz
tBUF	Bus Free Time Between a STOP and START Condition		1.3			μs
tHD:STA	Hold Time (Repeated) START Condition ⁶		0.6			μs
tLOW	LOW Period of SCL_EN1 Clock		1.3			μs
tHIGH	HIGH Period of SCL_EN1 Clock		0.6			μs
tSU:STA	Setup Time for a Repeated START Condition		0.6			μs
tHD:DAT	Data Hold Time ⁷		0		0.9	μs
tSU:DAT	Data Setup Time ⁸		100			ns
tR	Rise Time of Both SDA_EN2 and SCL_EN1 Signals		20 + 0.1C _B		300	ns
tF	Fall Time of Both SDA_EN2 and SCL_EN1 Signals		20 + 0.1C _B		300	ns
tSU:STO	Setup Time for STOP Condition		0.6			μs
C _B	Capacitive Load for Each Bus Line	C _B — total capacitance of one bus line in pF			400	pF
C _{I/O}	I/O Capacitance (SDA_EN2, SCL_EN1)				10	pF

1. I_{LIMIT} is adjustable in I²C mode (using register [coil_peak \(page 23\)](#)) and fixed to 1.75A in parallel interface mode
2. Due to slope compensation of the current limit, I_{LIMIT} changes with duty cycle - see [Figure 16 on page 10](#).
3. The logic input levels V_{IH} and V_{IL} allow for 1.8V supplied driving circuit
4. A pulldown current of 5μA is equal to a pulldown resistor of 300kΩ at 1.5V

5. During every startup the logic level of the pin I2C/EN is checked. If a logic low is detected, the pin I2C/EN is forced to V_{ISET} . If the resulting current is below $I_{RESET_I2C/EN}$, an external resistor R_{ISET} is assumed (mode: parallel interface mode with adjustable output currents).
6. After this period, the first clock pulse is generated.
7. A device must internally provide a hold time of at least 300ns for the SDA_EN2 signal (referred to the V_{IHMIN} of the SCL_EN1 signal) to bridge the undefined region of the falling edge of SCL_EN1.
8. A fast-mode device can be used in a standard-mode system, but the requirement $t_{SU:DAT} = t_{R} + 250ns$ must then be met. This is automatically the case if the device does not stretch the LOW period of the SCL_EN1 signal. If such a device does stretch the LOW period of the SCL_EN1 signal, it must output the next data bit to the SDA_EN2 line $t_{R\ max} + t_{SU:DAT} = 1000 + 250 = 1250ns$ before the SCL_EN1 line is released.

Timing Diagrams

Figure 3. I²C mode Timing Diagram

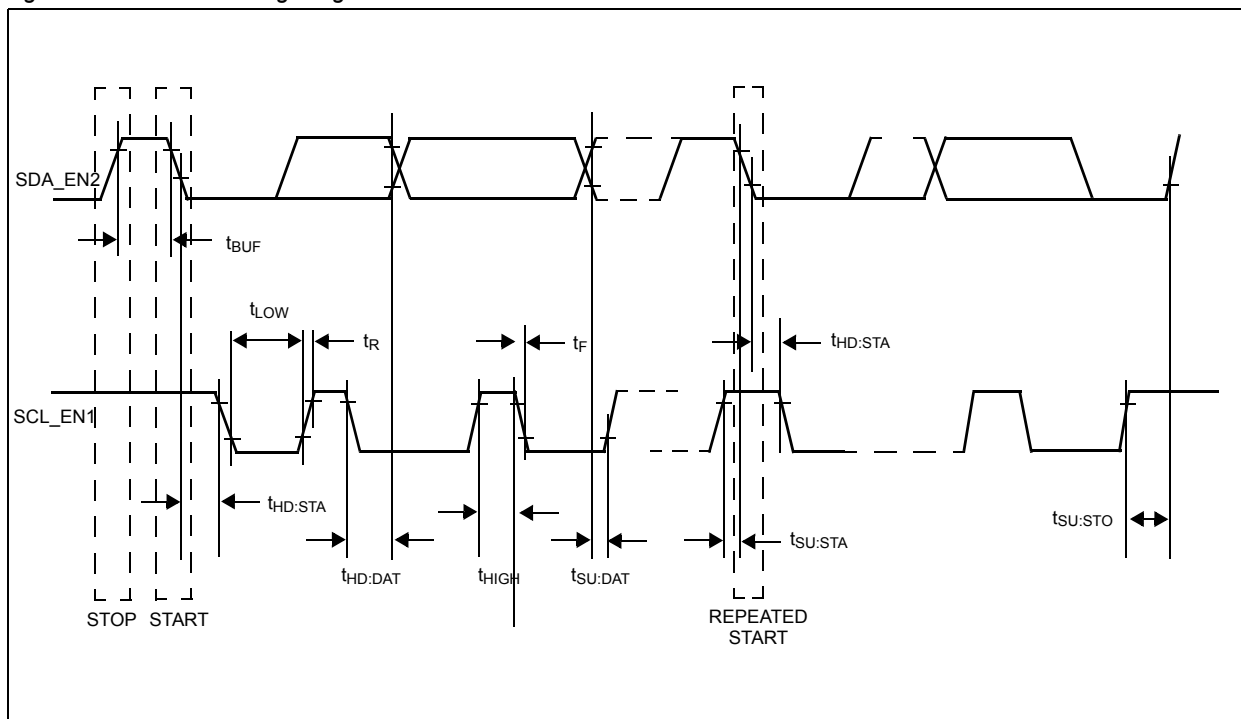

7 Typical Operating Characteristics

$V_{IN} = 3.6V$, $T_A = +25^\circ C$ (unless otherwise specified)

Figure 4. DCDC Efficiency vs. V_{IN}

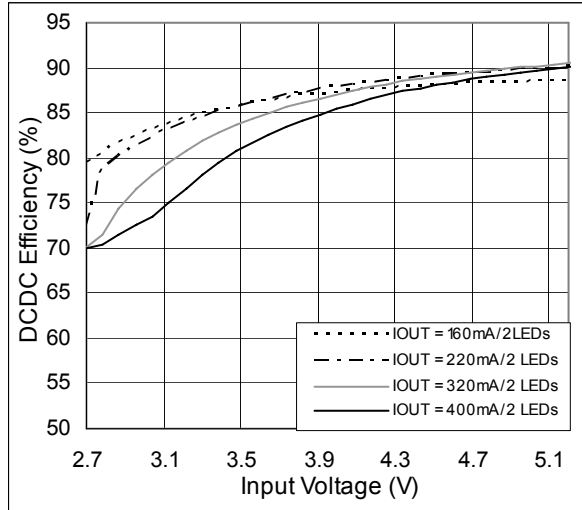

Figure 5. Application Efficiency (P_{LED}/P_{VIN}) vs. V_{IN}

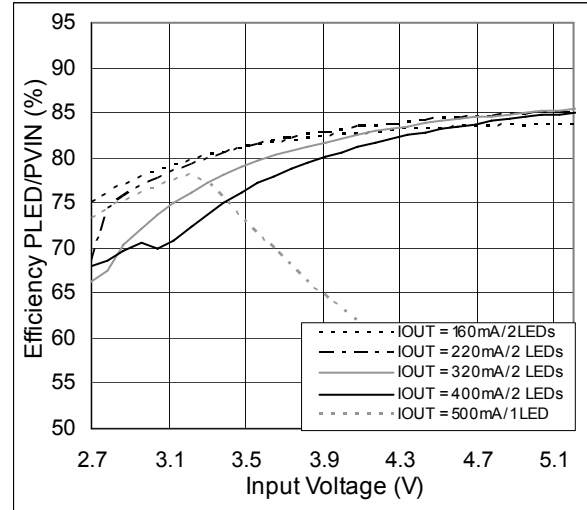

Figure 6. I_{LED} Startup (two LEDs, $I_{LED_OUT}=320mA$)

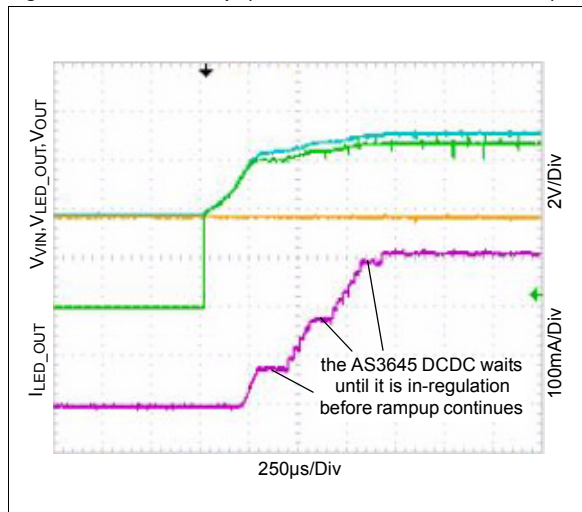

Figure 7. I_{VIN} Startup (two LEDs, $I_{LED_OUT}=400mA$)

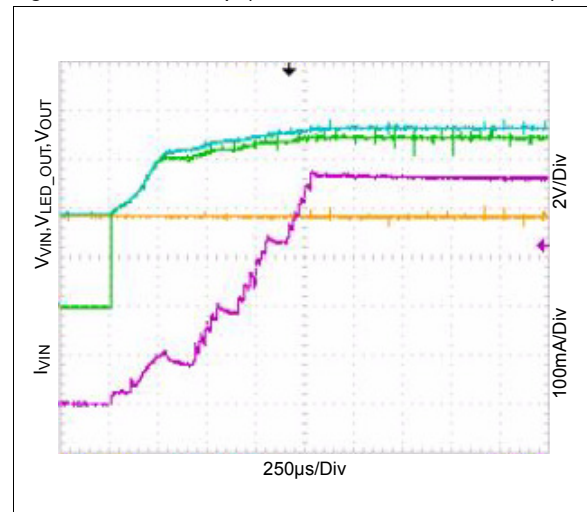

Figure 8. I_{LED} Startup (two LEDs, $I_{LED_OUT}=40mA$)

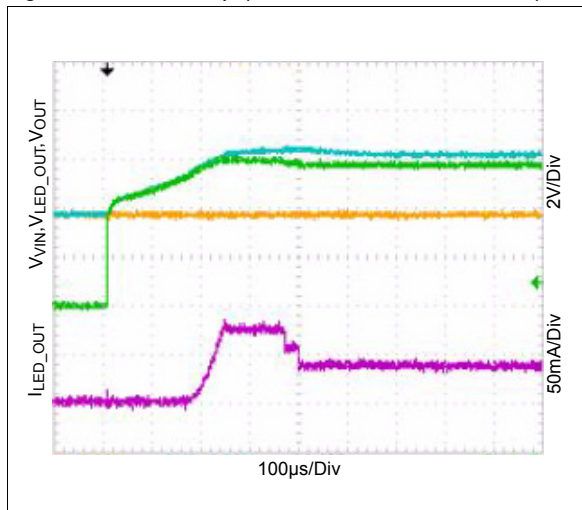

Figure 9. V_{OUT} / I_{LED_OUT} ripple, $I_{LED_OUT} = 320mA$

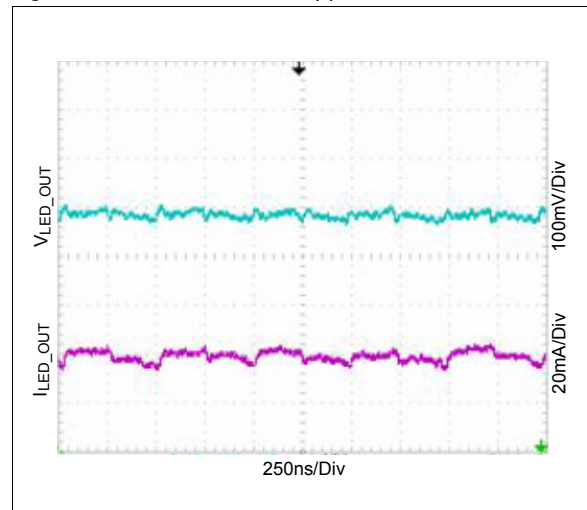

Figure 10. ILED Rampdown (ILED_OUT=320mA)

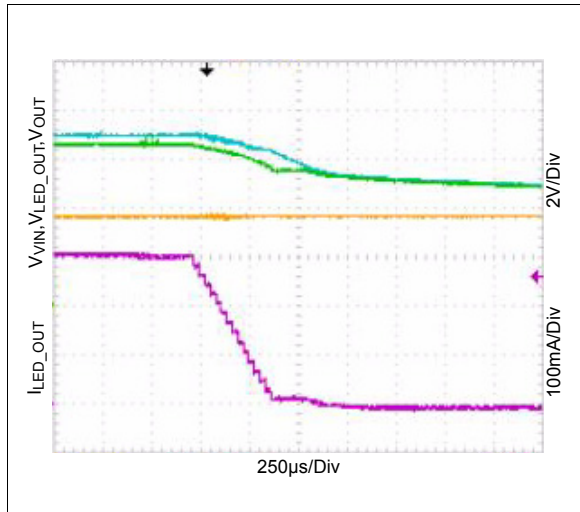

Figure 11. ILED_OUT Linearity of current sink

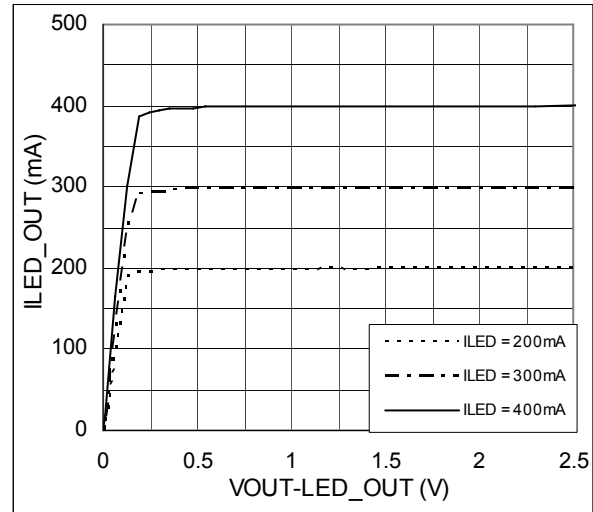

Figure 12. ILED_OUT vs. Riset(Torch Mode, 1 LED)

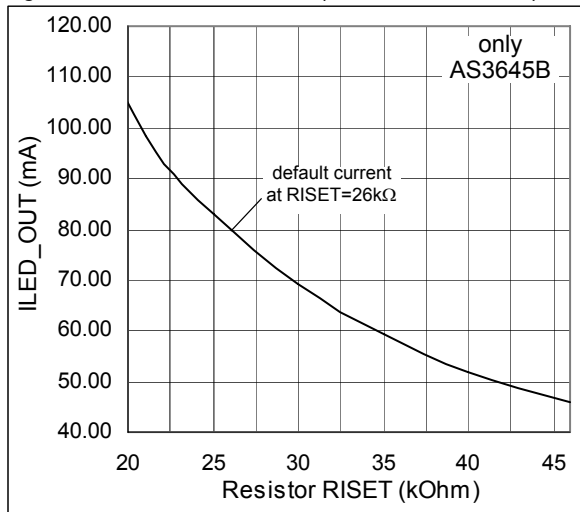

Figure 13. ILED_OUT vs. TAMB

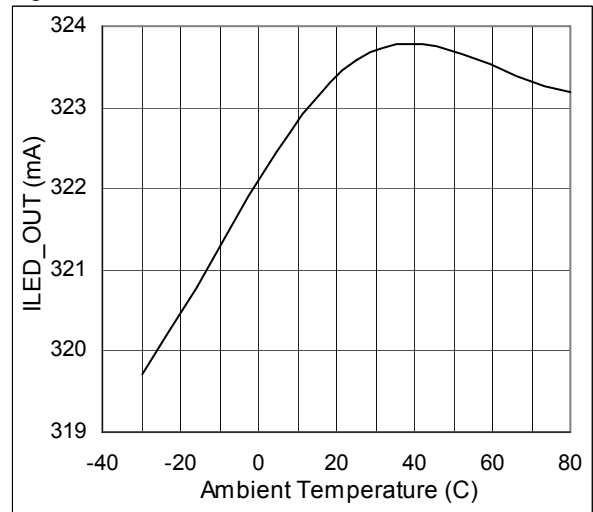

Figure 14. Oscillator frequency fCLK vs. TAMB

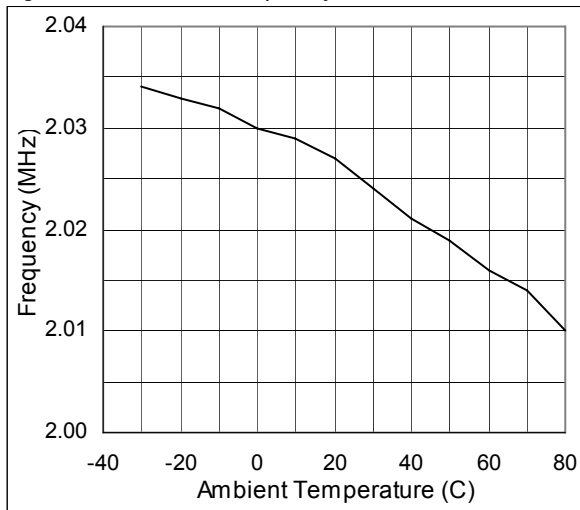
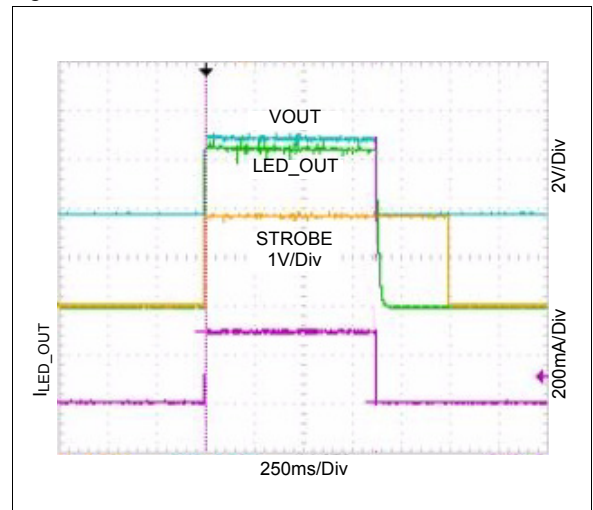

Figure 15. Flash Timeout



8 Detailed Description

The AS3645 is a high performance DCDC step up converter with internal PMOS and NMOS switches. Its output is connected to a flash LED¹ with an internal current source. A separate current source is used to connect an indicator LED.

The AS3645 can be operated in the following modes:

1. I²C mode with full control of all the current settings (the maximum flash current of up to 1000mA can be achieved in this operating mode only) - selected with I2C/EN=H
2. parallel interface mode with fixed output currents (500mA flash current for a single LED, 320mA flash current for two flash LEDs) - selected with I2C/EN=L
3. parallel interface mode with adjustable output currents - selected by connecting a resistor (R_{ISSET}) on pin I2C/EN. All flash LED currents (pin LED_OUT) can be adjusted with this resistor (max 500mA flash current for a single LED, max 320mA flash current for two flash LED).

The advantage of the parallel interface mode is the simple control of the AS3645 whereas the I²C mode allows for adjusting of all the currents and operating functions.

Internal Circuit

The AS3645 includes a fixed frequency DCDC step-up with accurate startup control. Together with the two output current sources (on LED_OUT or IND_OUT) it includes several protection and safety functions as shown in the following internal blockdiagram:

Figure 16. AS3645 internal circuit

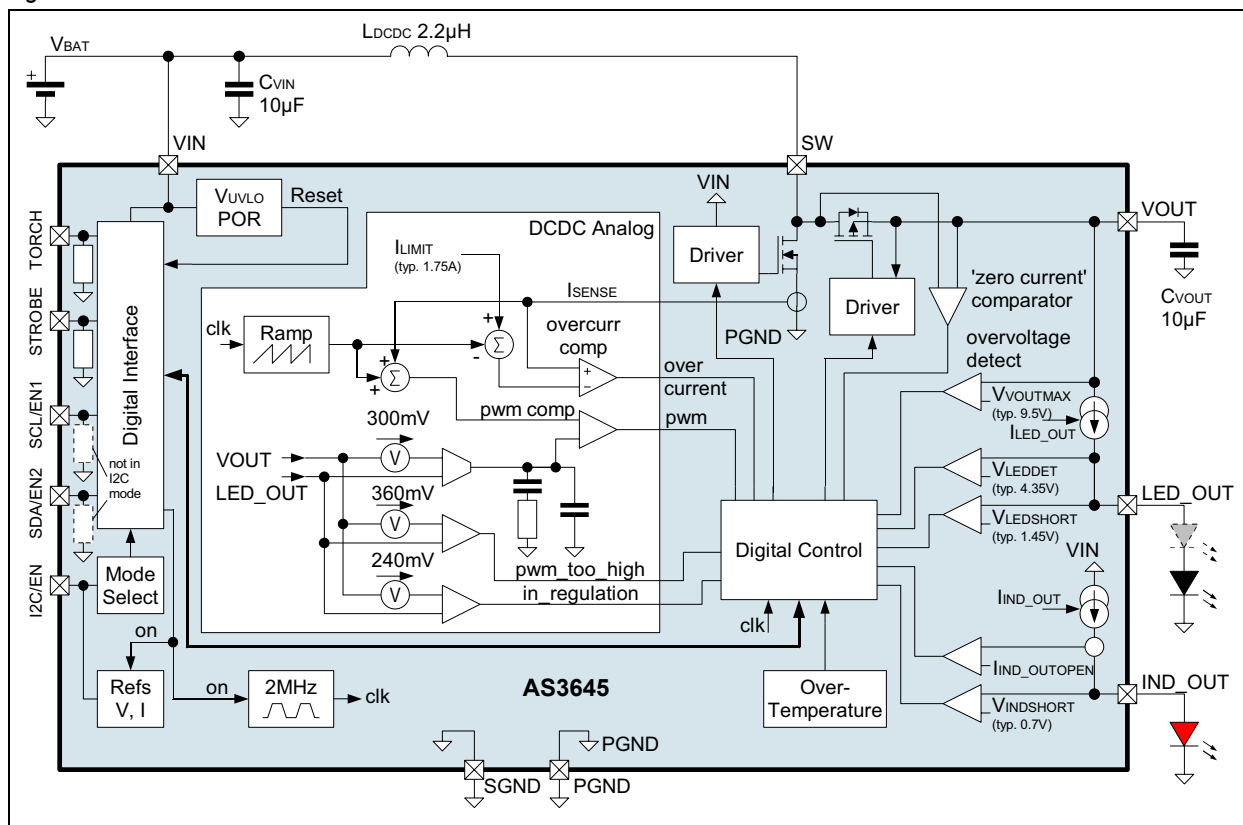

The DCDC converter always operates in PWM mode (exception: PFM mode is allowed during startup until single/dual LED detection is done. See [Single/Dual LED Detection](#) on page 12) to reduce EMI in EMI sensitive systems.

1. A single or dual flash LEDs connected in series is supported.

Protection and Fault Detection Functions

The protection functions protect the AS3645 and the LED(s) against physical damage. In most cases a register bit is set, which can be readout in I²C mode. In I²C mode, the fault bits are cleared by a I²C readout of the fault register. In parallel interface mode the fault bits are cleared when the device enters shutdown mode.

Overvoltage Protection

In case of no or a broken LED(s) at the pin LED_OUT and an enabled DCDC converter, the voltage on VOUT rises until it reaches V_{VOUTMAX} (overvoltage condition). If this condition is detected, the DCDC converter is stopped, the current sources are disabled and the bit [fault_ovp](#) (see page 24) is set.

DCDC Inductor Peak Current Limitation

To limit the maximum current from the battery, the DCDC converter limits its current through the coil to I_{LIMIT}. If within a single cycle I_{LIMIT} is reached and afterwards (still in the same cycle) the current through the coil reaches zero, a shorted coil is assumed. If this condition is detected, the DCDC is stopped, the current sources are disabled and the bit [fault_coil_peak](#) (see page 23) is set.

Short Circuit Protection

After the startup of the DCDC converter, the voltage on LED_OUT is continuously monitored and compared against V_{LEDSHORT}. If the voltage stays below V_{LEDSHORT}, the DCDC is stopped (as a shorted LED is assumed), the current sources are disabled and the bit [fault_led_short](#) (see page 24) is set.

Indicator LED open/short Detection

After the indicator current source is enabled and if the voltage on pin IND_OUT stays below V_{INDSHORT}, a shorted indicator LED is assumed. Then the bit [fault_ind_led](#) (see page 24) is set and the indicator current source is disabled.

If the current through the indicator LED stays below I_{IND_OUTOPEN}, the register bit [fault_ind_led](#) is also set, but the current source is not disabled².

Overtemperature Protection

The junction temperature of the AS3645 is continuously monitored. If the temperature exceeds T_{OVTEMP}, the DCDC is stopped, the current sources are disabled and the bit [fault_overtemp](#) (see page 24) is set. The driver cannot be re-enabled unless the junction temperature drops below T_{OVTEMP}-T_{OVTEMPHYST}.

Flash Timeout

If the flash is started³ a timeout timer is started in parallel. If the flash time exceeds t_{FLASHTIMEOUT}⁴, the DCDC is stopped and the flash current source (on pin LED_OUT) is disabled. In I²C mode and if the flash duration is defined by the STROBE input ([strobe_on](#) = 1 and [strobe_type](#) = 1, see Figure 22 on page 17) the bit [fault_timeout](#) (see page 24) is set.

Supply undervoltage Protection

If the voltage on the pin VIN (=battery voltage) is or falls below V_{VULO}, the AS3645 is kept in shutdown state⁵ and in I²C mode all registers are set to their default state.

-
2. To avoid erroneously disabling of the indicator current source due to short voltage drops on the supply.
 3. In I²C mode see section [Flash Strobe Timings](#) (see page 16), in parallel interface mode by setting SCL/EN1=1 and SDA/EN2=1
 4. Can be adjusted in I²C mode
 5. In parallel interface mode, after VIN rises above V_{VULO}, the AS3645 waits for the pins SCL/EN1=0, SDA/EN2=0 and TORCH=0 before accepting any inputs. This avoids oscillations effects for low batteries.

Single/Dual LED Maximum Current Protection

If a dual flash LED is detected (see [Single/Dual LED Detection on page 12](#)) the maximum flash current is limited to ILED_OUT (400mA) in I²C mode⁶ and parallel interface mode with fixed output currents.

Note: Disable the single/dual LED detection and protection when using `boost_current=1` by setting `led_det_on=0` and `led_amount=0`.

Device Startup and Operating Mode selection

AS3645A Operating Mode

The AS3645A chooses the operating mode according to the digital input level on pin I2C/EN. If I2C/EN=H, I²C mode is selected, if I2C/EN=L parallel interface mode with fixed output currents is used.

AS3645B Operating Mode

Figure 17. AS3645B operating mode selection flow

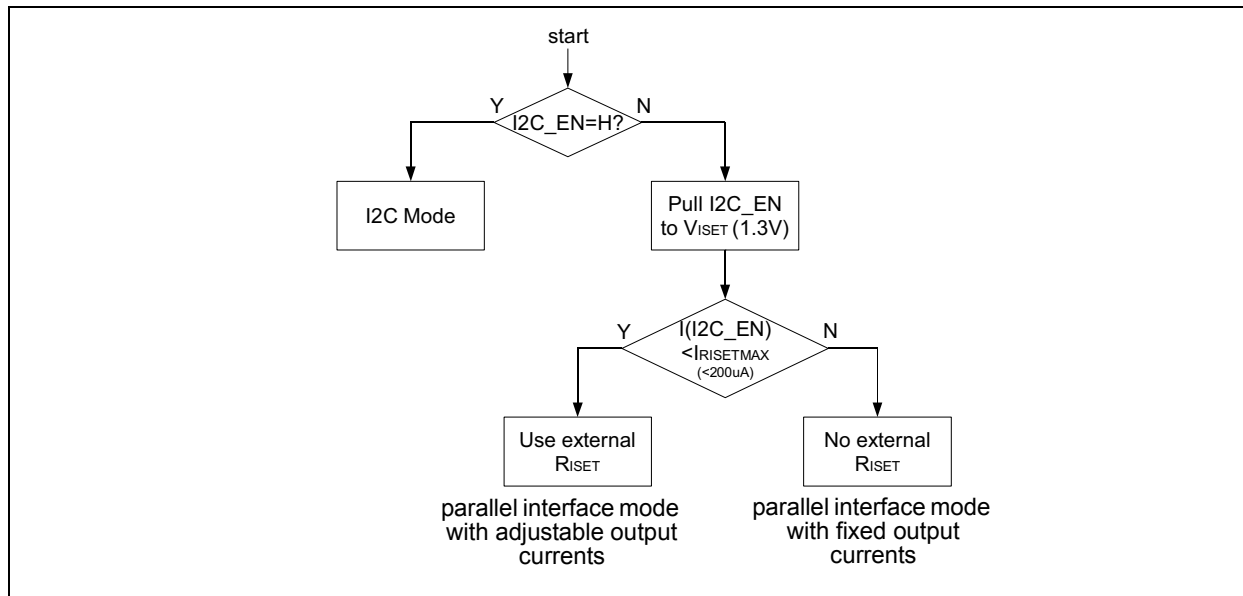

If the AS3645B detects a high level on I2C/EN, I²C mode is used. If a low level is detected, the pin I2C/EN is pulled to VISET. If the resulting current into the pin I2C/EN is then lower than IRISETMAX, the mode 'parallel interface mode with adjustable output currents' is selected otherwise 'parallel interface mode with fixed output currents' is selected.

Single/Dual LED Detection

During startup of the main current source (pin LED_OUT), the current source is ramped to ILED_DET. If the voltage on pin LED_OUT is above VLED_DET, two flash LEDs in series are assumed and the bit `led_amount` (see [page 24](#)) is set, otherwise cleared:

6. To obtain higher currents, set `led_det_on=0` and `led_amount=0`.

Figure 18. Single/Dual LED detection

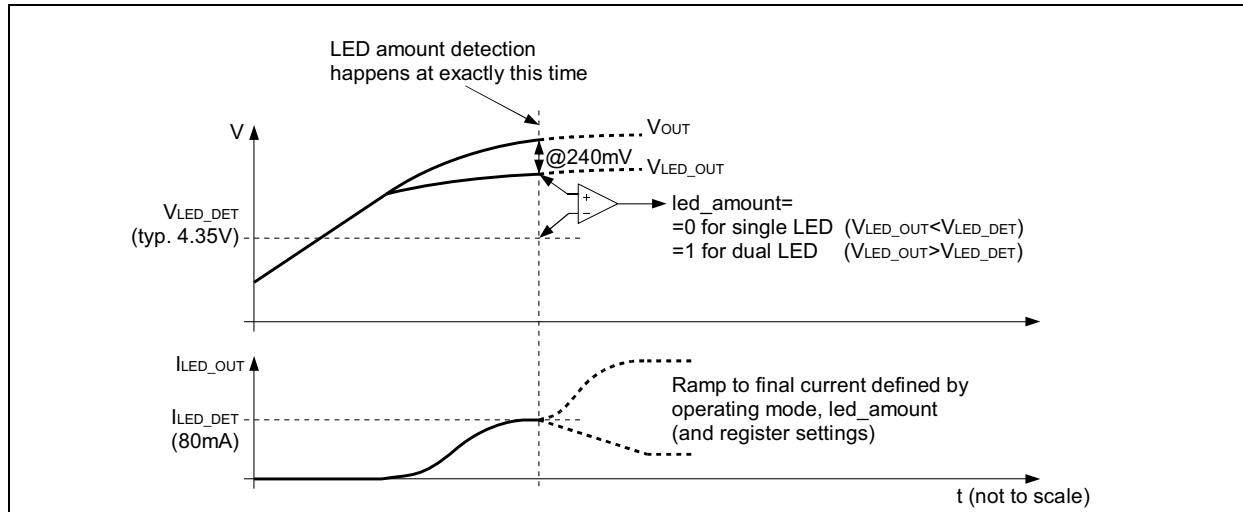

The detection can be disabled in I²C mode by clearing the bit `led_det_on` (see page 21). If disabled, the bit `led_amount` default value ('1' for dual LED) is used. This bit can be overwritten by software in I²C mode.

In parallel interface mode, the pin STROBE is used as an open drain output to indicate if a single or a dual LED was detected: STROBE=L indicates single LED, STROBE=H (open drain) indicates dual LED detected.

Note: When using `boost_current=1`, always set `led_det_on=0` and `led_amount=0` to disable the single/dual LED detection.

Interface Mode: parallel interface mode with fixed output currents

The output currents and operating mode in parallel interface mode with fixed output currents are selected according to the following table⁷:

Table 4. parallel interface mode with fixed output currents

SCL/EN1	SDA/EN2	TORCH	STROBE	Device Mode	LED_OUT output current	IND_OUT output current
0	0	0	X	shutdown	0	0
0	0	1	L=single H=dual LED detected	external torch mode	80mA single LED 40mA dual LED	0
0	1	X		assist light mode	80mA single LED 40mA dual LED	0
1	0	X	X	indicator mode	0	2.5mA
1	1	X	L=single H=dual LED detected	flash mode (with 850ms flash timeout)	500mA single LED 320mA dual LED	0

7. The mode is selected by tying I2C/EN to ground

Interface Mode: parallel interface mode with adjustable output currents - only AS3645B

The output currents and operating mode in parallel interface mode with fixed output currents is selected according to the following table⁸:

Table 5. parallel interface mode with fixed output currents

SCL/EN1	SDA/EN2	TORCH	STROBE	Device Mode	LED_OUT output current	IND_OUT output current
0	0	0	X	shutdown	0	0
0	0	1	L=single H=dual LED detected	external torch mode	26kΩ/R _{ISSET} *80mA for single LED 26kΩ/R _{ISSET} *40mA for dual LED	0
0	1	X		assist light mode	26kΩ/R _{ISSET} *80mA for single LED 26kΩ/R _{ISSET} *40mA for dual LED	0
1	0	X	X	indicator mode	0	2.5mA (independent of R _{ISSET})
1	1	X	L=single H=dual LED detected	flash mode (with 850ms flash timeout)	26kΩ/R _{ISSET} *500mA for single LED ¹ 26kΩ/R _{ISSET} *320mA for dual LED	0

1. Maximum 500mA (single LED) or 320mA (dual LED) - use I²C mode to obtain higher currents

With the help of the resistor R_{ISSET}, the output current can be scaled. If the resistor R_{ISSET} is smaller as 26kΩ, the output current is increased (and vice versa).

8. The parallel interface mode with adjustable output currents is selected by connecting the resistor R_{ISSET} between the pin I2C/EN and GND

Interface Mode: I²C mode

The output currents and operating mode in parallel interface mode with fixed output currents are selected according to the following table⁹:

Table 6. I²C mode

AS3645 configuration					operating mode and currents			
SCL/EN1 and SDA/EN2	TORCH	STROBE	mode_setting (see page 23)	out_on (see page 23)	Condition	Mode	LED_OUT output current	IND_OUT output current
I ² C commands are accepted	X	X	10, 01 or 11	0		standby	0	0
	X	X	00	X	ext_torch_on (see page 23) = 0			
	0	X			ext_torch_on = 1			
	1	X			ext_torch_on = 1	external torch mode	defined by assist_light_current (see page 21) (20mA-320mA)	0
	X	X	10	1		assist light mode	defined by assist_light_current (see page 21) (20mA-320mA)	0
	X	X	01	1		indicator mode	0	defined by ind_current (see page 21) (2.5mA-10mA)
	X	X	11	1	strobe_on (see page 23) = 0	flash mode;	defined by flash_current (see page 22) (200mA-1000mA) maximum 2x500mA for dual LED see Single/Dual LED Maximum Current Protection on page 12 and Single/Dual LED Detection on page 12	0
	X	0->1			strobe_on = 1 and strobe_type (see page 23) = 0	flash duration defined by flash_timeout (see page 20)		
	X	1			strobe_on = 1 and strobe_type = 1	flash duration defined by STROBE input; timeout defined by flash_timeout		

9. The I²C mode is selected by a high level on I2C/EN

Flash Strobe Timings

In I²C mode, the flash timing¹⁰ is defined as follows:

- Flash duration defined by register `flash_timeout` and flash started immediately when this mode is selected by the I²C command (see Figure 19):
set `strobe_on` = 0, start the flash by setting `out_on` = 1
- Flash duration defined by register `flash_timeout` and flash started with a rising edge on pin STROBE (see Figure 20):
set `strobe_on` = 1 and `strobe_type` = 0
- Flash start and timing defined by the pin STROBE; the flash duration is limited by the timeout timer defined by `flash_timeout` (see Figure 21 and Figure 22):
set `strobe_on` = 1 and `strobe_type` = 1

Figure 19. AS3645 flash duration defined by `flash_timeout` without using STROBE input

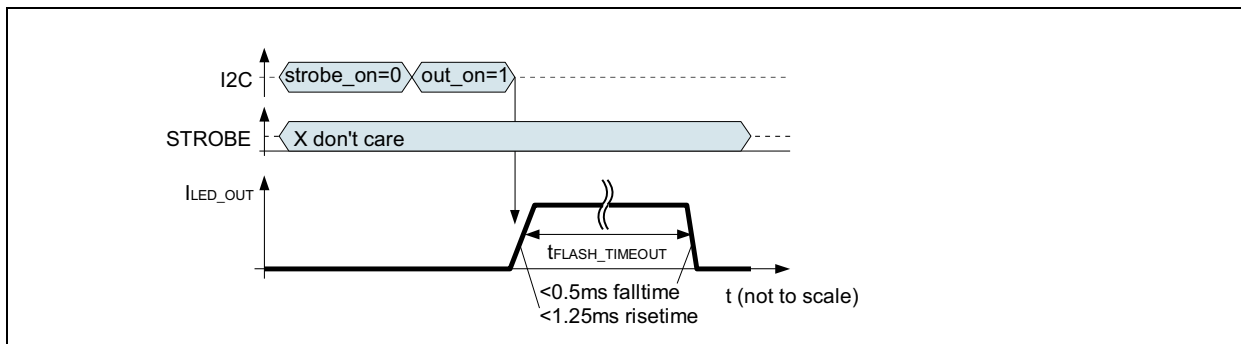

Figure 20. AS3645 flash duration defined by `flash_timeout`, starting flash with STROBE rising edge

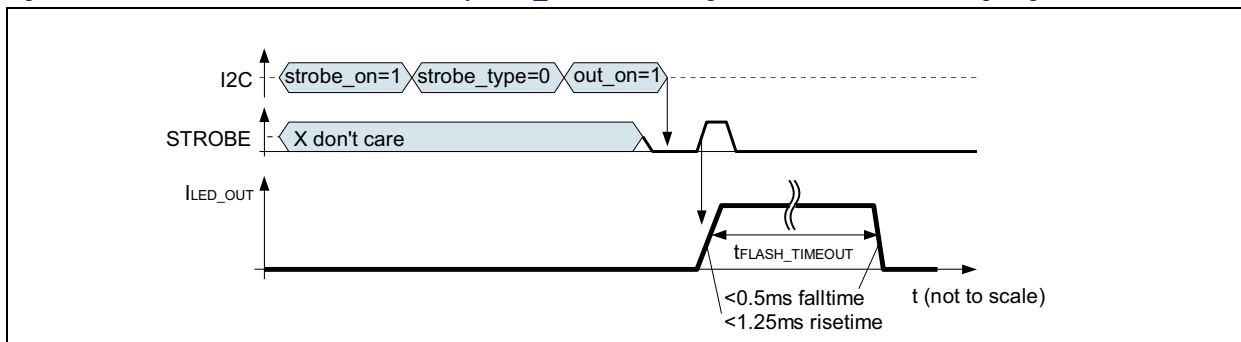
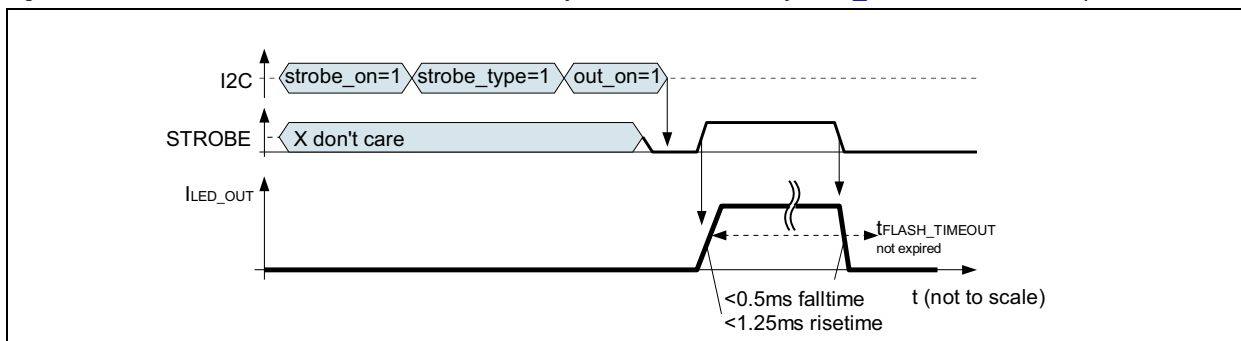
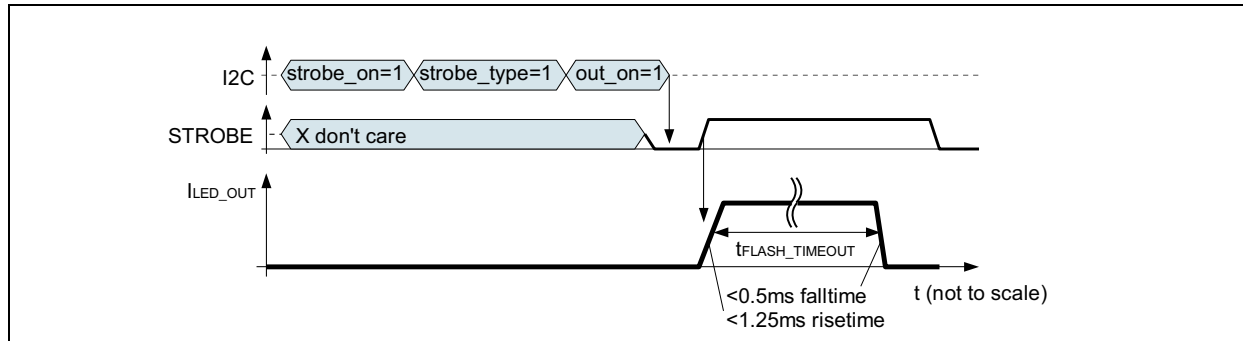

Figure 21. AS3645 flash duration and start defined by STROBE, limited by `flash_timeout`; timer not expired



¹⁰ flash mode is selected by setting `mode_setting` = 11 and `out_on` = 1

Figure 22. AS3645 flash duration and start defined by STROBE, limited by *flash_timeout*; timer expired



I²C mode Serial Data Bus

The AS3645 supports the I²C bus protocol. A device that sends data onto the bus is defined as a transmitter and a device receiving data as a receiver. The device that controls the message is called a master. The devices that are controlled by the master are referred to as slaves. A master device that generates the serial clock (SCL_EN1), controls the bus access, and generates the START and STOP conditions must control the bus. The AS3645 operates as a slave on the I²C bus. Within the bus specifications a standard mode (100kHz maximum clock rate) and a fast mode (400kHz maximum clock rate) are defined. The AS3645 works in both modes. Connections to the bus are made through the open-drain I/O lines SDA_EN2 and SCL_EN1.

The following bus protocol has been defined (Figure 23):

- Data transfer may be initiated only when the bus is not busy.
- During data transfer, the data line must remain stable whenever the clock line is HIGH. Changes in the data line while the clock line is HIGH are interpreted as control signals.

Accordingly, the following bus conditions have been defined:

Bus Not Busy

Both data and clock lines remain HIGH.

Start Data Transfer

A change in the state of the data line, from HIGH to LOW, while the clock is HIGH, defines a START condition.

Stop Data Transfer

A change in the state of the data line, from LOW to HIGH, while the clock line is HIGH, defines the STOP condition.

Data Valid

The state of the data line represents valid data when, after a START condition, the data line is stable for the duration of the HIGH period of the clock signal. The data on the line must be changed during the LOW period of the clock signal. There is one clock pulse per bit of data.

Each data transfer is initiated with a START condition and terminated with a STOP condition. The number of data bytes transferred between START and STOP conditions are not limited, and are determined by the master device. The information is transferred byte-wise and each receiver acknowledges with a ninth bit.

Acknowledge

Each receiving device, when addressed, is obliged to generate an acknowledge after the reception of each byte. The master device must generate an extra clock pulse that is associated with this acknowledge bit.

A device that acknowledges must pull down the SDA_EN2 line during the acknowledge clock pulse in such a way that the SDA_EN2 line is stable LOW during the HIGH period of the acknowledge-related clock pulse. Of course, setup and hold times must be taken into account. A master must signal an end of data to the slave by not generating an acknowledge bit on the last byte that has been clocked out of the slave. In this case, the slave must leave the data line HIGH to enable the master to generate the STOP condition.

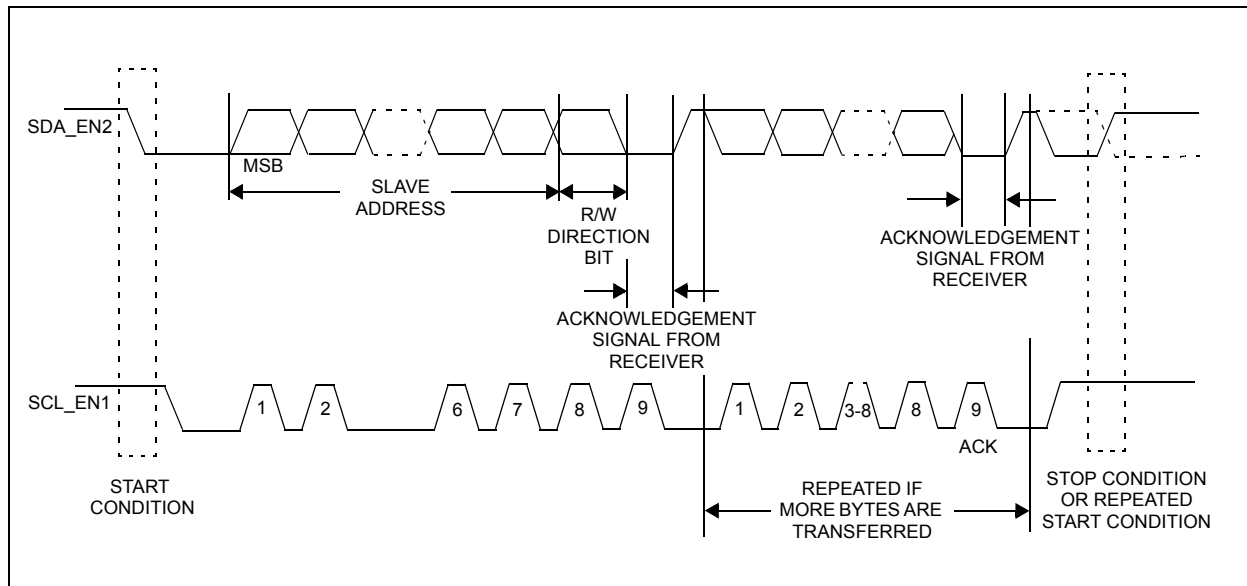
Figure 23. Data Transfer on I²C Serial Bus

Depending upon the state of the R/W bit, two types of data transfer are possible:

1. **Data transfer from a master transmitter to a slave receiver.** The first byte transmitted by the master is the slave address. Next follows a number of data bytes. The slave returns an acknowledge bit after each received byte. Data is transferred with the most significant bit (MSB) first.
2. **Data transfer from a slave transmitter to a master receiver.** The master transmits the first byte (the slave address). The slave then returns an acknowledge bit, followed by the slave transmitting a number of data bytes. The master returns an acknowledge bit after all received bytes other than the last byte. At the end of the last received byte, a "not acknowledge" is returned. The master device generates all of the serial clock pulses and the START and STOP conditions. A transfer is ended with a STOP condition or with a repeated START condition. Since a repeated START condition is also the beginning of the next serial transfer, the bus is not released. Data is transferred with the most significant bit (MSB) first.

The AS3645 can operate in the following two modes:

1. **Slave Receiver Mode (Write Mode):** Serial data and clock are received through SDA_EN2 and SCL_EN1. After each byte is received an acknowledge bit is transmitted. START and STOP conditions are recognized as the beginning and end of a serial transfer. Address recognition is performed by hardware after reception of the slave address and direction bit (see Figure 24). The slave address byte is the first byte received after the master generates the START condition. The slave address byte contains the 7-bit AS3645 address, which is 0110000, followed by the direction bit (R/W), which, for a write, is 0.¹¹ After receiving and decoding the slave address byte the device outputs an acknowledge on the SDA_EN2 line. After the AS3645 acknowledges the slave address + write bit, the master transmits a register address to the AS3645. This sets the register pointer on the AS3645. The master may then transmit zero or more bytes of data, with the AS3645 acknowledging each byte received. The address pointer will increment after each data byte is transferred. The master generates a STOP condition to terminate the data write.
2. **Slave Transmitter Mode (Read Mode):** The first byte is received and handled as in the slave receiver mode. However, in this mode, the direction bit indicates that the transfer direction is reversed. Serial data is transmitted on SDA_EN2 by the AS3645 while the serial clock is input on SCL_EN1. START and STOP conditions are recognized as the beginning and end of a serial transfer (Figure 25 and Figure 26). The slave address byte is the first byte received after the master generates a START condition. The slave address byte contains the 7-bit AS3645 address, which is 0110000, followed by the direction bit (R/W), which, for a read, is 1.¹² After receiving and decoding the slave address byte the device outputs an acknowledge on the SDA_EN2 line. The AS3645 then begins to transmit data starting with the register address pointed to by the register pointer. If the

11. The address for writing to the AS3645 is 60h = 01100000b

12. The address for read mode from the AS3645 is 61h = 01100001b

register pointer is not written to before the initiation of a read mode the first address that is read is the last one stored in the register pointer. The AS3645 must receive a “not acknowledge” to end a read.

Figure 24. Data Write - Slave Receiver Mode

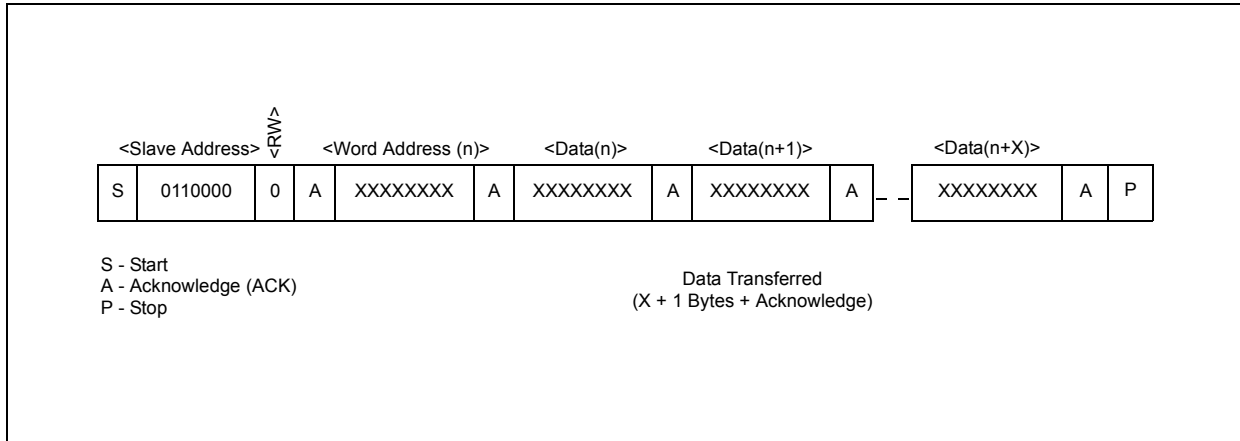

Figure 25. Data Read (from Current Pointer Location) - Slave Transmitter Mode

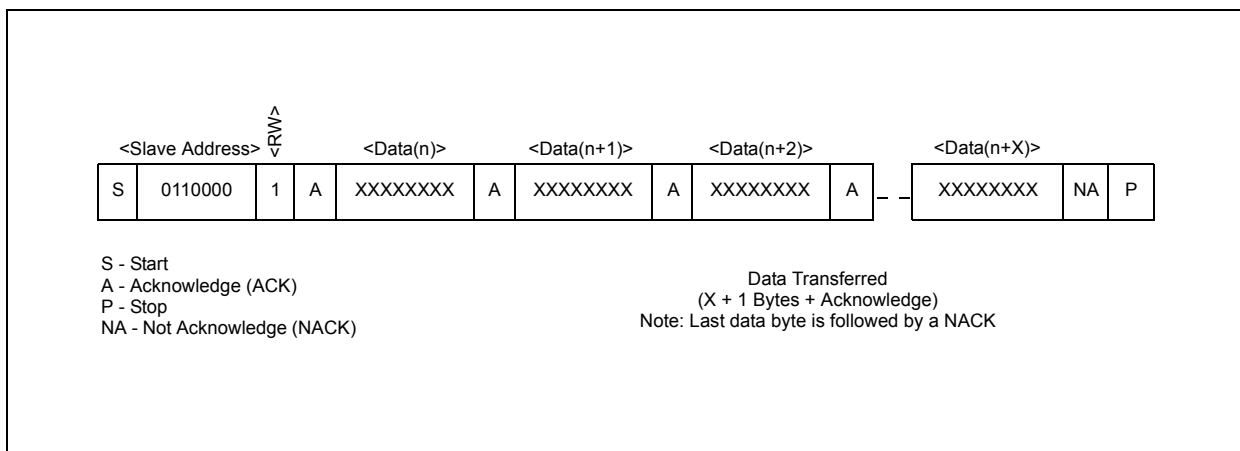
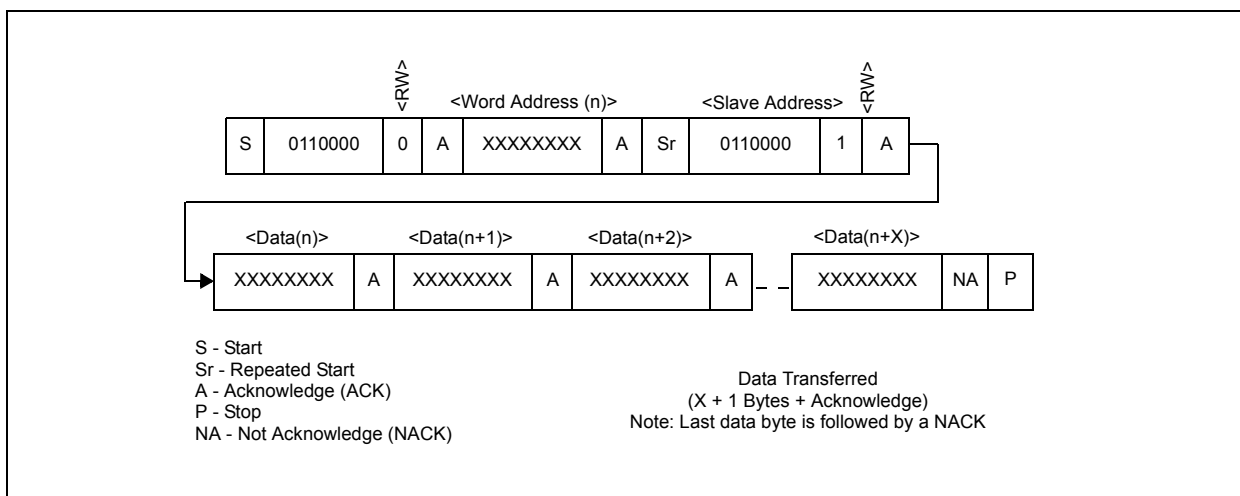

Figure 26. Data Read (Write Pointer, Then Read) - Slave Receive and Transmit



Register Description (I²C mode)

Table 7. *Design Info Register*

Addr: 0		Design Info Register		
This register has a fixed ID				
Bit	Bit Name	Default	Access	Description
7:0	fixed_id	11h	R	This is a fixed identification (e.g. to verify the I ² C communication)

Table 8. *Version Control Register*

Addr: 1		Version Control Register		
This register defines design versions				
Bit	Bit Name	Default	Access	Description
3:0	version	Xh	R	AS3645 version number
7:4	reserved	Xh	R	reserved - don't use

Table 9. *Indicator/Flash Timer Register*

Addr: 2		Indicator/Flash Timer Register			
This register defines Indicator Current and Flash Timeouts					
Bit	Bit Name	Default	Access	Description	
3:0	flash_timeout	Fh	R/W	Define the duration of the flash timeout timer	
				0h	100ms
				1h	150ms
				2h	200ms
				3h	250ms
				4h	300ms
				5h	350ms
				6h	400ms
				7h	450ms
				8h	500ms
				9h	550ms
				Ah	600ms
				Bh	650ms
				Ch	700ms
				Dh	750ms
Eh	800ms				
Fh	850ms				
5:4	vref_offset	00	R/W	Adjust the single/dual LED detection voltage V _{LED_DET} (see Single/Dual LED Detection on page 12)	
				00	V _{LED_DET} =4.35V
				01	V _{LED_DET} =4.65V
				10	V _{LED_DET} =4.05V
				11	V _{LED_DET} =4.95V

Table 9. Indicator/Flash Timer Register (Continued)

Addr: 2		Indicator/Flash Timer Register			
This register defines Indicator Current and Flash Timeouts					
Bit	Bit Name	Default	Access	Description	
7:6	ind_current	00	R/W	Define the current on pin IND_OUT in indicator mode	
				00	IIND_OUT = 2.5mA
				01	IIND_OUT = 5.0mA
				10	IIND_OUT = 7.5mA
				11	IIND_OUT = 10mA

Table 10. Current Set Register

Addr: 3		Current Set Register				
This register defines the Current Settings						
Bit	Bit Name	Default	Access	Description		
2:0	assist_light_current	1h	R/W	Define the current on pin LED_OUT in assist light and external torch mode (only used in I ² C mode) ¹		
					boost_current=0	boost_current=1
				0h	20mA	(40mA) - don't use
				1h	40mA	(80mA) - don't use
				2h	60mA	(120mA) - don't use
				3h	80mA	(160mA) - don't use
				4h	100mA	200mA
				5h	120mA	240mA
				6h	140mA	280mA
3	led_det_on	1	R/W	Enables the led amount detection (single/dual LED)		
				0	Number of LEDs detection disabled	
				1	Number of LEDs detection enabled	

Table 10. Current Set Register (Continued)

Addr: 3		Current Set Register				
		This register defines the Current Settings				
Bit	Bit Name	Default	Access	Description		
7:4	flash_current	6h	R/W	Define the current on pin LED_OUT in flash mode (only used in I ² C mode) ^{2,3}		
					boost_current=0	boost_current=1
				0h	200mA	(400mA) - don't use
				1h	220mA	(440mA) - don't use
				2h	240mA	(480mA) - don't use
				3h	260mA	520mA
				4h	280mA	560mA
				5h	300mA	600mA
				6h	320mA	640mA
				7h	340mA	680mA
				8h	360mA	720mA
				9h	380mA	don't use
				Ah	400mA	
				Bh	420mA (dual flash LED: set led_det_on=0, led_amount=0)	
				Ch	440mA (dual flash LED: set led_det_on=0, led_amount=0)	
				Dh	460mA (dual flash LED: set led_det_on=0, led_amount=0)	
Eh	480mA (dual flash LED: set led_det_on=0, led_amount=0)					
Fh	500mA (dual flash LED: set led_det_on=0, led_amount=0)					

1. In parallel interface mode the assist and torch current is set to 80mA for a single LED and 40mA for a dual LED
2. In parallel interface mode the flash current is set to 500mA for one LED and 320mA (each LED) for two LEDs
3. For a dual flash LED leave boost_current=0 (max 500mA for each LED - combined current of 1000mA)

Table 11. Control Register

Addr: 4		Control Register			
		This register defines the operating mode and different protection functions in I ² C mode			
Bit	Bit Name	Default	Access	Description	
1:0	mode_setting	00	R/W	Define the AS3645 operating mode (only used in I ² C mode)	
				00	external torch mode; see also ext_torch_on (page 23)
				01	indicator mode
				10	assist light mode
				11	flash mode
2	strobe_on	1	R/W	Enables the STROBE input	
				0	STROBE input disabled
				1	STROBE input enabled in flash mode
3	out_on	0	R/W	Enables the output current sources (pin LED_OUT and IND_OUT)	
				0	outputs disabled
				1	outputs enabled (automatically cleared after a flash pulse)
4	ext_torch_on	1	R/W	Enables the external torch mode input (pin TORCH)	
				0	disable input pin TORCH
				1	enable input pin TORCH; see also mode_setting (page 23)
5	strobe_type	1	R/W	Defines if the STROBE input is edge or level sensitive; see also bit strobe_on (page 23)	
				0	STROBE input is edge sensitive
				1	STROBE input is level sensitive
7:6	coil_peak	10	R/W	Defines the maximum coil current (parameter ILIMIT)	
				00	ILIMIT = 1.25A
				01	ILIMIT = 1.5A
				10	ILIMIT = 1.75A
				11	ILIMIT = 2.0A

Table 12. Fault Register

Addr: 5		Fault Register			
		This register identifies all the different fault conditions and provide information about the LED detection			
Bit	Bit Name	Default	Access	Description	
0	reserved	X	R	reserved - don't use	
1	fault_coil_peak	0	R	see DCDC Inductor Peak Current Limitation on page 11	
				0	No fault
				1	Coil current has exceeded ILIMIT

Table 12. *Fault Register (Continued)*

Addr: 5		Fault Register			
This register identifies all the different fault conditions and provide information about the LED detection					
Bit	Bit Name	Default	Access	Description	
2	fault_ind_led	0	R	see Indicator LED open/short Detection on page 11	
				0	No fault
				1	Indicator LED (pin IND_OUT) fault
3	led_amount	1	R/W	see Single/Dual LED Detection on page 12	
				0	Single LED detected (pin LED_OUT)
				1	Dual LED detected (pin LED_OUT)
4	fault_timeout	0	R	see Flash Timeout on page 11	
				0	No fault
				1	Flash timeout exceeded
5	fault_overtemp	0	R	see Overtemperature Protection on page 11	
				0	No fault
				1	Junction temperature limit has been exceeded
6	fault_led_short	0	R	see Short Circuit Protection on page 11	
				0	No fault
				1	A shorted LED is detected (pin LED_OUT)
7	fault_ovp	0	R	see Overvoltage Protection on page 11	
				0	No fault
				1	An overvoltage condition is detected (pin VOUT)

Table 13. *Boost Register*

Addr: Dh		Boost Register			
This register can boost the flash current					
Bit	Bit Name	Default	Access	Description	
0	boost_current ¹	0	R	see flash_current on page 22	
				0	Normal flash current (up to 500mA)
				1	Double flash current

1. Write 55h to register 0Fh ([Password](#)) before changing this register bit; when setting `boost_current=1` also set `led_det_on=0`, `led_amount=0` to disable led amount detection.

Table 14. *Password Register*

Addr: Fh		Password Register		
This register is the password protection for writing to the Boost register				
Bit	Bit Name	Default	Access	Description
7:0	password	0	W	Write 01010101b (55h) to this register to unlock the Boost register for the next I ² C write command only

Register Map (I²C mode)

Table 15. Register Map

Register Definition	Addr	Default	Content							
Name			b7	b6	b5	b4	b3	b2	b1	b0
Design Info	0	11h	fixed_id							
Version Control	1	XXh	reserved				version			
Indicator/Flash Timer	2	0Fh	ind_current		vref_offset		flash_timeout			
Current Set	3	69h	flash_current				led_det_on	assist_light_current		
Control	4	B4h	coil_peak		strobe_type	ext_torch_on	out_on	strobe_on	mode_setting	
Fault	5	08h	fault_ovp	fault_led_short	fault_overtemp	fault_timeout	led_amount	fault_in_d_led	fault_coil_peak	reserved
Boost	Dh	00h								boost_current
Password	Fh	00h	password							

9 Application Information

The AS3645 supports different interface types. It is possible to connect the AS3645 directly to an (existing) I²C bus (e.g. from the baseband processor)¹³:

Figure 27. Application Circuit using I²C mode of BaseBand

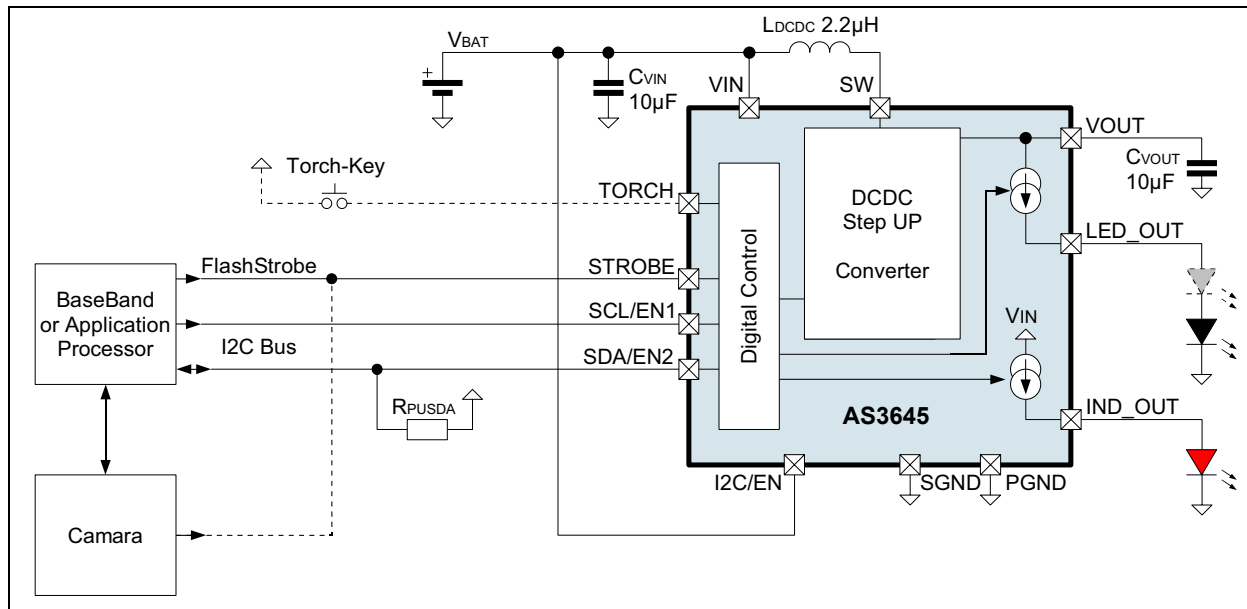

As the TORCH pin has an internal debounce timer and pulldown it is possible to connect TORCH directly to a push button (The control signal on the pins SCL/EN1 and SDA/EN2 always have higher priority compared to TORCH). If the camera I²C bus can be used use following circuit:

Figure 28. Application Circuit using I²C mode of Camera

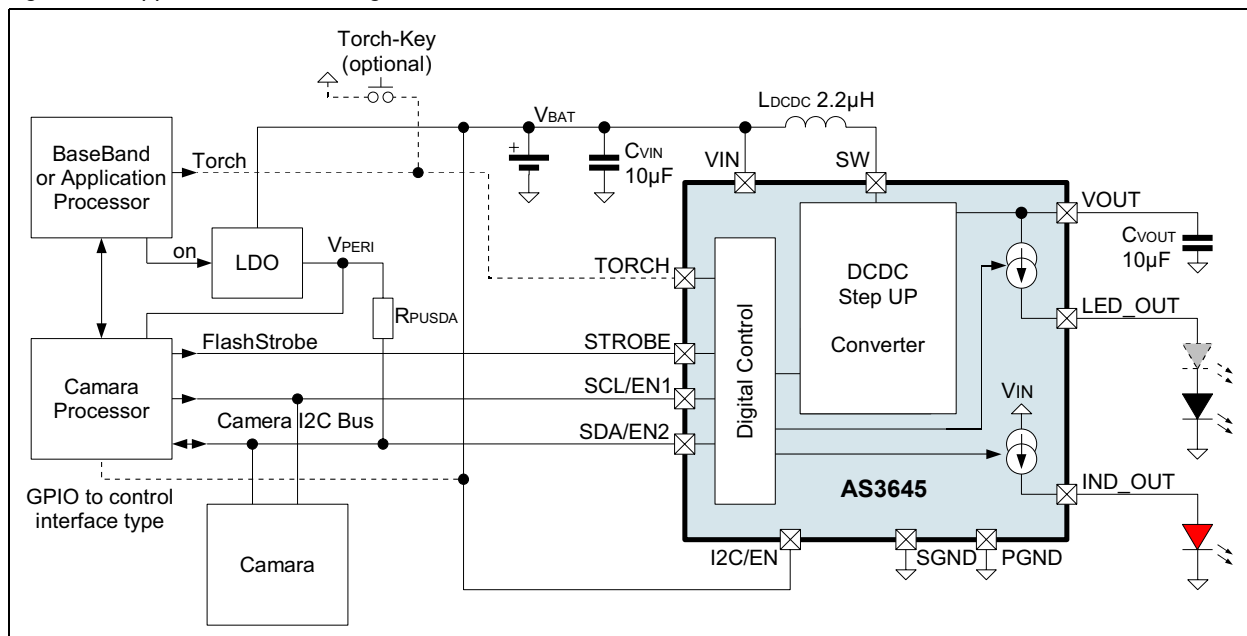

13. The STROBE line is optional as the flash-strobe command can be sent via I²C.

For a very straightforward control (parallel control) use following circuit (RISSET or RTXMASK can only be used for AS3645B):

Figure 29. Application Circuit using parallel interface mode

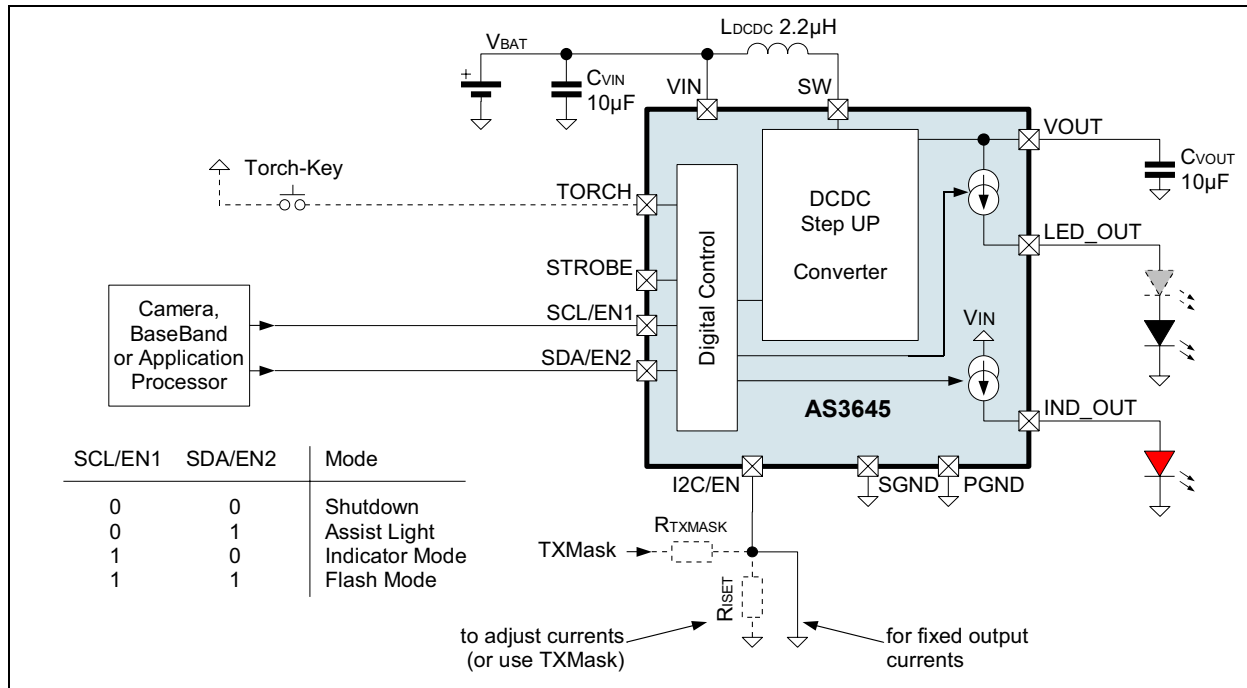

TXMask-ing of battery current - only AS3645B

If the battery has to supply two high current loads at the same time (e.g. the AS3645 flash and a RF-power amplifier) it is possible, that the total current causes a high voltage drop on the battery and with a low battery resulting in a shutdown of the complete system. In order to avoid this shutdown, the AS3645 can reduce its current with the signal 'TXMask' using the circuit shown in Figure 29.

The TXMask signal is connected to e.g. the (RF-) power amplifier enable pin (active high if the PA is enabled). This reduces the flash current if the power amplifier is enabled and avoids the unexpected shutdown of the system.

Note: The voltage on I2C/EN in shutdown of the AS3645 should be less than V_{TXMASK} (0.5V) to avoid switching erroneously into I²C mode.

The internal flash timeout timer ($t_{FLASHTIMEOUT}$) to limit the total flash duration, is not affected by the TXMask function (see [Flash Timeout on page 11](#)).

External Components

Input Capacitor C_{VIN}

Low ESR input capacitors reduce input switching noise and reduce the peak current drawn from the battery. Ceramic capacitors are required for input decoupling and should be located as close to the device as is practical.

Table 16. Recommended Input Capacitor

Part Number	C	TC Code	ESR	Rated Voltage	Size	Manufacturer
GRM188R60J126	10µF +/-10% >5µF@1.9V >4µF@5V	X5R	30mΩ	6V3	0603	Murata www.murata.com

If a different input capacitor is chosen, ensure similar ESR value and at least 4 μ F capacitance at the maximum input supply voltage. Larger capacitor values (C) may be used without limitations.

Output Capacitor C_{VOUT}

Low ESR capacitors should be used to minimize V_{OUT} ripple. Multi-layer ceramic capacitors are recommended since they have extremely low ESR and are available in small footprints. The capacitor should be located as close to the device as is practical.

X5R dielectric material is recommended due to their ability to maintain capacitance over wide voltage and temperature range.

Table 17. Recommended Output Capacitor

Part Number	C	TC Code	ESR	Rated Voltage	Size	Manufacturer
GRM219R61A116U	10 μ F +/-10% >4.2 μ F@5V >4 μ F@10V	X5R	30m Ω	10V	0805	Murata www.murata.com

If a different output capacitor is chosen, ensure similar ESR values and at least 4 μ F capacitance at 10V output voltage.

Inductor L_{DCDC}

The fast switching frequency (2MHz) of the AS3645 allows for the use of small SMDs for the external inductor. The saturation current I_{SATURATION} should be chosen to be above the maximum value of I_{LIMIT}¹⁴. The inductor should have low DC resistance (DCR) to reduce the I²R power losses - high DCR values will reduce efficiency.

Table 18. Recommended Inductor

Part Number	L	DCR	I _{SATURATION}	Size	Manufacturer
ELL3FU2R2NBN	2.2 μ H >1.54 μ H @ 1.9A	typ. 120m Ω max. 160m Ω	1.8A	3x3x1.1mm max 1.2mm height	Panasonic www.panasonic.com
FDSE0312-2R2M	2.2 μ H >1.54 μ H @ 2.3A	typ. 140m Ω max. 160m Ω	2.3A	3x3x1.1mm max 1.2mm height	Toko www.toko.com

If a different inductor is chosen, ensure similar DCR values and at least 1.5 μ H inductance at I_{LIMIT}.

PCB Layout Guideline

The high speed operation requires proper layout for optimum performance. Route the power traces first and try to minimize the area and wire length of the two high frequency/high current loops:

Loop1: C_{VIN} - L_{DCDC} - pin SW - pin PGND - C_{VIN}

Loop2: C_{VIN} - L_{DCDC} - pin SW - pin V_{OUT} - C_{VOUT} - pin PGND - C_{VIN}

At the pin PGND a single via (or more vias, which are closely combined) connects to the common ground plane. This via(s) will isolate the DCDC high frequency currents from the common ground (as most high frequency current will flow between Loop1 and Loop2 and will not pass the ground plane) - see the 'island' in [Figure 30](#).

14. Can be adjusted in I²C mode with register [coil_peak](#) (see page 23)

Figure 30. Layout recommendation

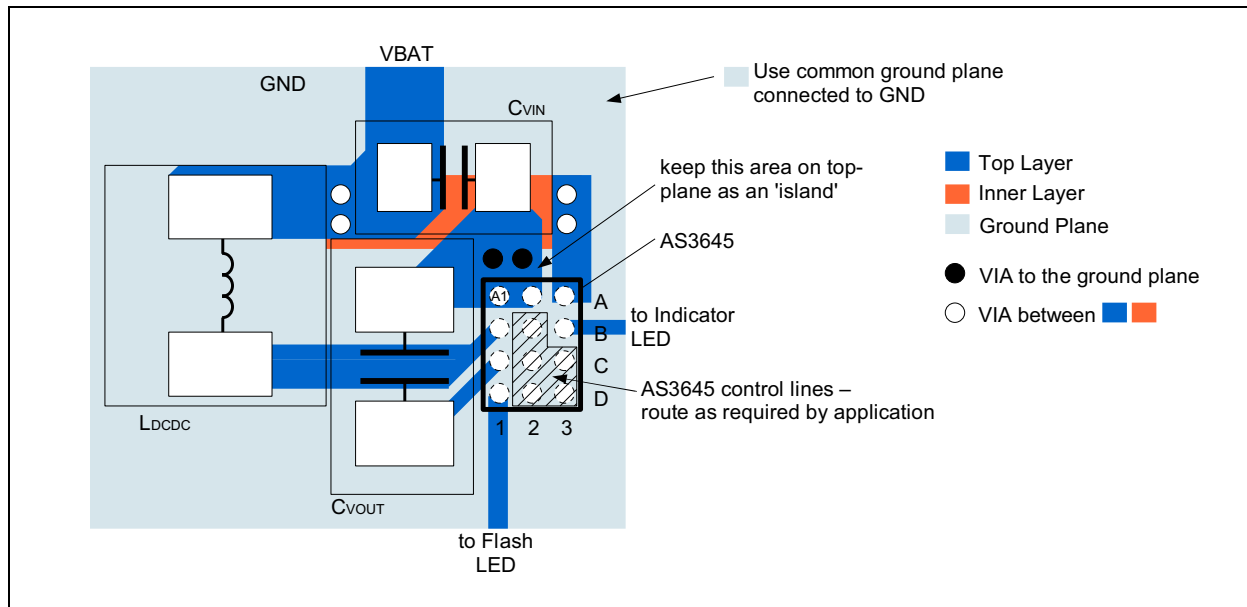

Note: If component placement rules allow, move all components close to the AS3645 to reduce the area and length of Loop1 and Loop2.

Application Self Testing Guideline

The AS3645 includes several fault and configuration detection functions (see [Protection and Fault Detection Functions on page 11](#)). Therefore it is possible to self-test the application during assembly and manufacturing of the end-device. Depending on the operating mode following procedures are possible (for all tests the AS3645 should be started first by enabling e.g. torch mode to test the flash LED and the DCDC converter and enabling indicator mode to test the indicator LED):

Table 19. Application Self Testing Failure Detection Procedures

Possible Failure	can be identified in	
	I ² C mode if production equipment has access to SCL/EN1 and SDA_EN2	parallel interface mode if production equipment can measure the battery current and can initiate flash/torch and indicator
Enable AS3645 Torch Mode and wait at least 1ms to detect following faults		
Flash LED is open	register bit <code>fault_ovp</code> (see page 24) is set	no (additional) current on the battery
Flash LED is shorted (single or dual LED configuration)	register bit <code>fault_led_short</code> (see page 24) is set	no (additional) current on the battery
One Flash LED is shorted in a dual LED configuration	register bit <code>led_amount</code> (see page 24) is not set (a '1' is expected in a dual LED configuration)	STROBE=L see Single/Dual LED Detection (see page 12) ¹
High ohmic connection of the flash LED (single LED configuration)	either bit <code>fault_ovp</code> is set or bit <code>led_amount</code> is set	no (additional) current on the battery or STROBE=H (open drain) ²
High ohmic connection of the flash LED (dual LED configuration)	register bit <code>fault_ovp</code> is set	no (additional) current on the battery
Inductor missing or open	register bit <code>fault_led_short</code> is set	no (additional) current on the battery

Table 19. Application Self Testing Failure Detection Procedures (Continued)

Possible Failure	can be identified in	
	I ² C mode if production equipment has access to SCL/EN1 and SDA_EN2	parallel interface mode if production equipment can measure the battery current and can initiate flash/torch and indicator
Inductor shorted	register bit <code>fault_coil_peak</code> (see page 23) is set	no (additional) current on the battery
Output or input capacitor shorted	excessive current from the supply - if a battery is connected it will trigger its overcurrent protection	
Enable AS3645 Indicator Mode and wait at least 1ms to detect following faults		
Indicator LED shorted	register bit <code>fault_ind_led</code> (see page 24) is set	no (additional) current on the battery
Indicator LED open	register bit <code>fault_ind_led</code> is set	no (additional) current on the battery

1. Only possible if the test equipment has access to the STROBE pin
2. Only possible if the test equipment has access to the STROBE pin

10 Package Drawings and Markings

Figure 31. 12pin WL-CSP 2x1.6mm Marking

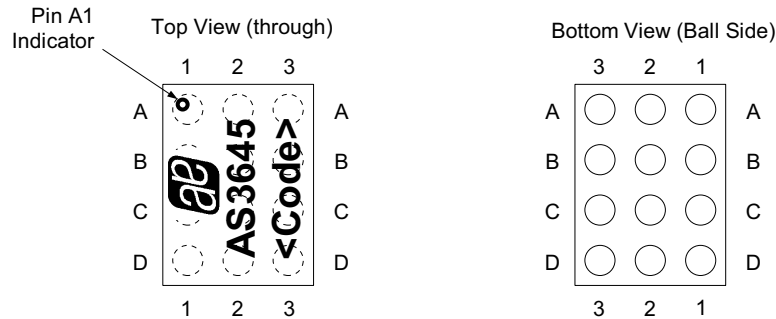

Note:

- Line 1: austriamicrosystems logo
- Line 2: AS3645 for AS3645A (see AS3645A Operating Mode on page 12)
AS364B for AS3645B (see AS3645B Operating Mode on page 12)
- Line 3: <Code>
Encoded Datecode (4 characters)

Figure 32. 12pin WL-CSP 2x1.6mm Package Dimensions

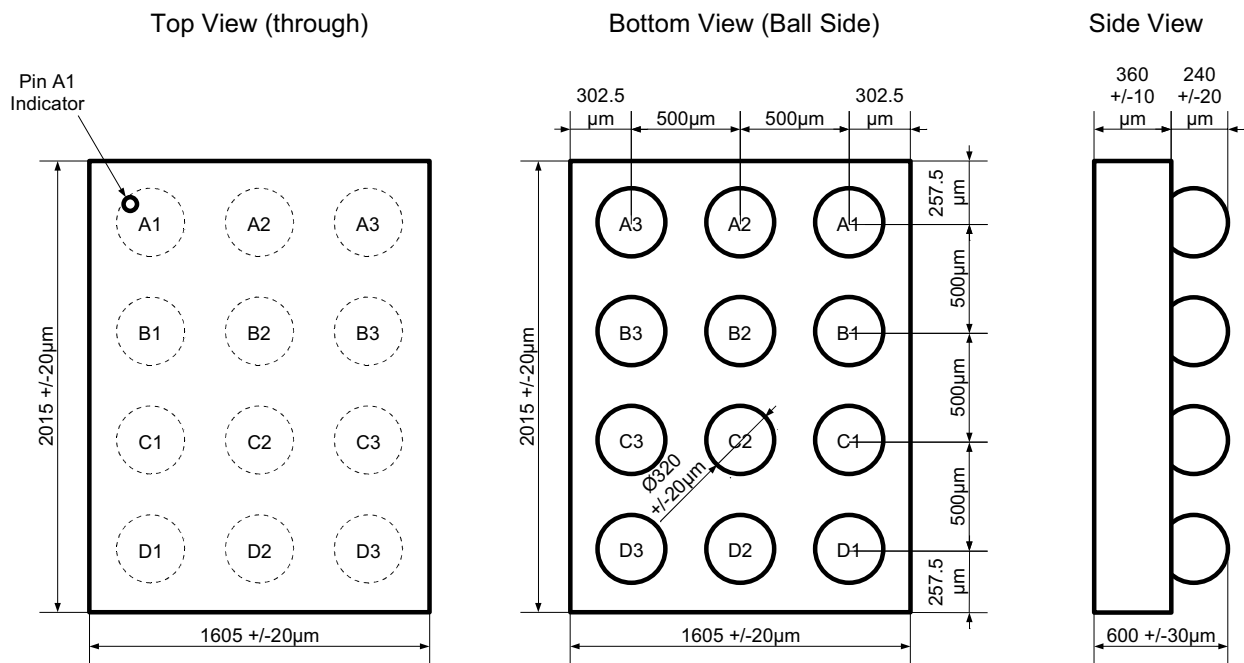

The coplanarity of the balls is 40µm.

11 Ordering Information

The devices are available as the standard products shown in [Table 20](#).

Table 20. Ordering Information

Model	Description	Delivery Form	Package
AS3645A-ZWLT ¹	Ultra Small High efficient single/dual LED Flash Driver with Safety Features without RISET detection (see AS3645A Operating Mode on page 12)	Tape & Reel	12-pin WL-CSP (2mm x 1.6mm) RoHS compliant / Pb-Free
AS3645B-ZWLT ²	Ultra Small High efficient single/dual LED Flash Driver with Safety Features with RISET detection (see AS3645B Operating Mode on page 12)	Tape & Reel	12-pin WL-CSP (2mm x 1.6mm) RoHS compliant / Pb-Free

1. AS3645A is the standard version.
2. Contact austriamicrosystems for availability of AS3645B.

Note: AS3645V-ZWLT

AS3645

V Version:

A...AS3645 without RISET detection function (see [AS3645A Operating Mode on page 12](#))

B...AS3645 with RISET detection function (see [AS3645B Operating Mode on page 12](#))

-

Z Temperature Range: -30°C - 85°C

WL Package: Wafer Level Chip Scale Package (WL-CSP) 2x1.6mm

T Delivery Form: Tape & Reel

Copyrights

Copyright © 1997-2010, austriamicrosystems AG, Schloss Premstaetten, 8141 Unterpremstaetten, Austria-Europe. Trademarks Registered ®. All rights reserved. The material herein may not be reproduced, adapted, merged, translated, stored, or used without the prior written consent of the copyright owner.

All products and companies mentioned are trademarks or registered trademarks of their respective companies.

Disclaimer

Devices sold by austriamicrosystems AG are covered by the warranty and patent indemnification provisions appearing in its Term of Sale. austriamicrosystems AG makes no warranty, express, statutory, implied, or by description regarding the information set forth herein or regarding the freedom of the described devices from patent infringement. austriamicrosystems AG reserves the right to change specifications and prices at any time and without notice. Therefore, prior to designing this product into a system, it is necessary to check with austriamicrosystems AG for current information. This product is intended for use in normal commercial applications. Applications requiring extended temperature range, unusual environmental requirements, or high reliability applications, such as military, medical life-support or life-sustaining equipment are specifically not recommended without additional processing by austriamicrosystems AG for each application. For shipments of less than 100 parts the manufacturing flow might show deviations from the standard production flow, such as test flow or test location.

The information furnished here by austriamicrosystems AG is believed to be correct and accurate. However, austriamicrosystems AG shall not be liable to recipient or any third party for any damages, including but not limited to personal injury, property damage, loss of profits, loss of use, interruption of business or indirect, special, incidental or consequential damages, of any kind, in connection with or arising out of the furnishing, performance or use of the technical data herein. No obligation or liability to recipient or any third party shall arise or flow out of austriamicrosystems AG rendering of technical or other services.



Contact Information

Headquarters

austriamicrosystems AG
A-8141 Schloss Premstaetten, Austria

Tel: +43 (0) 3136 500 0
Fax: +43 (0) 3136 525 01

For Sales Offices, Distributors and Representatives, please visit:

<http://www.austriamicrosystems.com/contact>