

FEATURES

- **HIGH POWER**
P1dB=48.0dBm at 2.6GHz
- **HIGH GAIN**
G1dB=10.0dB at 2.6GHz
- **PARTIALLY MATCHED TYPE**
- **HERMETICALLY SEALED PACKAGE**

RF PERFORMANCE SPECIFICATIONS (Ta= 25°C)

CHARACTERISTICS	SYMBOL	CONDITIONS	UNIT	MIN.	TYP.	MAX.
Output Power at 1dB Gain Compression Point	P1dB	VDS= 12V f = 2.6GHz IDSset≅8.0A	dBm	47.0	48.0	—
Power Gain at 1dB Gain Compression Point	G1dB		dB	9.0	10.0	—
Drain Current	IDS1		A	—	12.0	15.0
Power Added Efficiency	ηadd		%	—	39	—
Channel Temperature Rise	ΔTch		(VDS X IDS + Pin – P1dB) X Rth(c-c)	°C	—	—

Recommended gate resistance (Rg) : Rg = 30 Ω (Max.)

ELECTRICAL CHARACTERISTICS (Ta= 25°C)

CHARACTERISTICS	SYMBOL	CONDITIONS	UNIT	MIN.	TYP.	MAX.
Transconductance	gm	VDS= 3V IDS= 12.0A	S	—	20.0	—
Pinch-off Voltage	VGSoff	VDS= 3V IDS= 300mA	V	-1.0	-1.8	-3.0
Saturated Drain Current	IDSS	VDS= 3V VGS= 0V	A	—	38	—
Gate-Source Breakdown Voltage	VGSO	IGS= -10.0mA	V	-5	—	—
Thermal Resistance	Rth(c-c)	Channel to Case	°C/W	—	0.6	0.8

◆The information contained herein is presented only as a guide for the applications of our products. No responsibility is assumed by TOSHIBA for any infringements of patents or other rights of the third parties which may results from its use. No license is granted by implication or otherwise under any patent or patent rights of TOSHIBA or others.

The information contained herein is subject to change without prior notice. It is therefor advisable to contact TOSHIBA before proceeding with design of equipment incorporating this product.

ABSOLUTE MAXIMUM RATINGS (Ta= 25°C)

CHARACTERISTICS	SYMBOL	UNIT	RATING
Drain-Source Voltage	VDS	V	15
Gate-Source Voltage	VGS	V	-5
Drain Current	IDS	A	26.0
Total Power Dissipation (Tc= 25 °C)	PT	W	187.5
Channel Temperature	Tch	°C	175
Storage	Tstg	°C	-65 ~ +175

PACKAGE OUTLINE (2-16G1B)

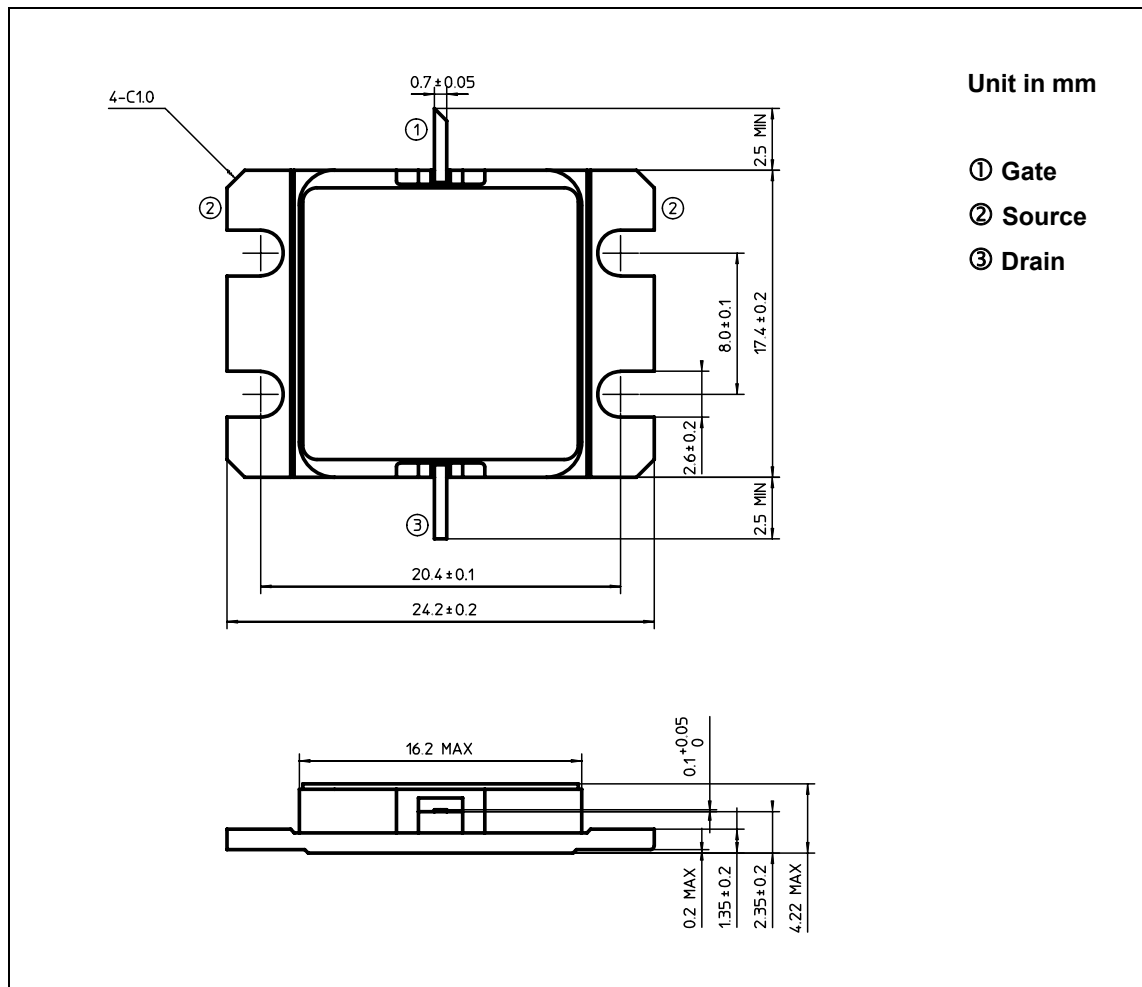

HANDLING PRECAUTIONS FOR PACKAGE MODEL

Soldering iron should be grounded and the operating time should not exceed 10 seconds at 260°C.

RF PERFORMANCE

Output Power (Pout) vs. Frequency

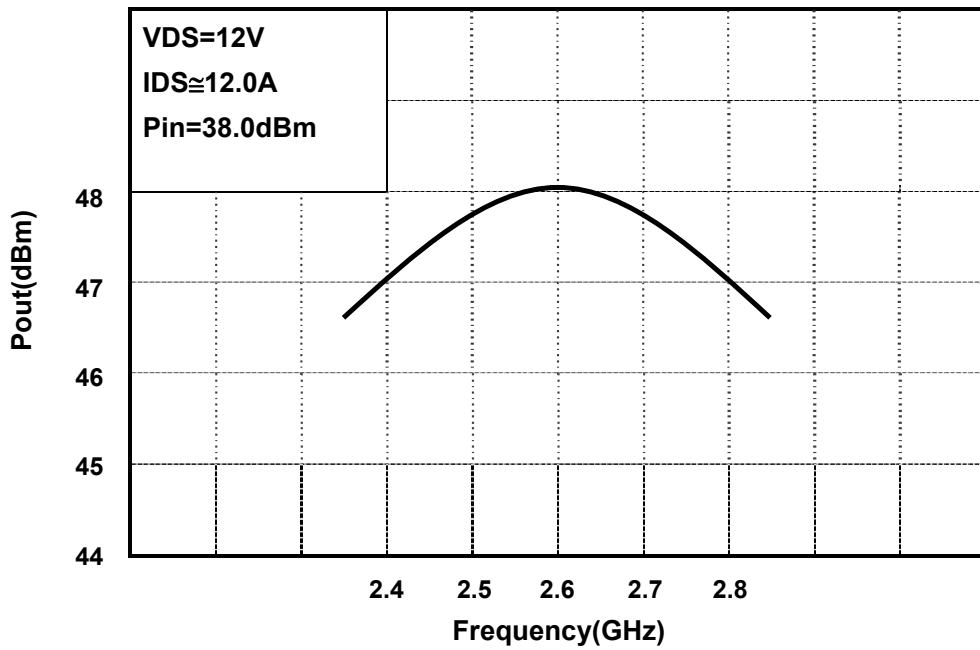

Output Power(Pout) vs. Input Power(Pin)

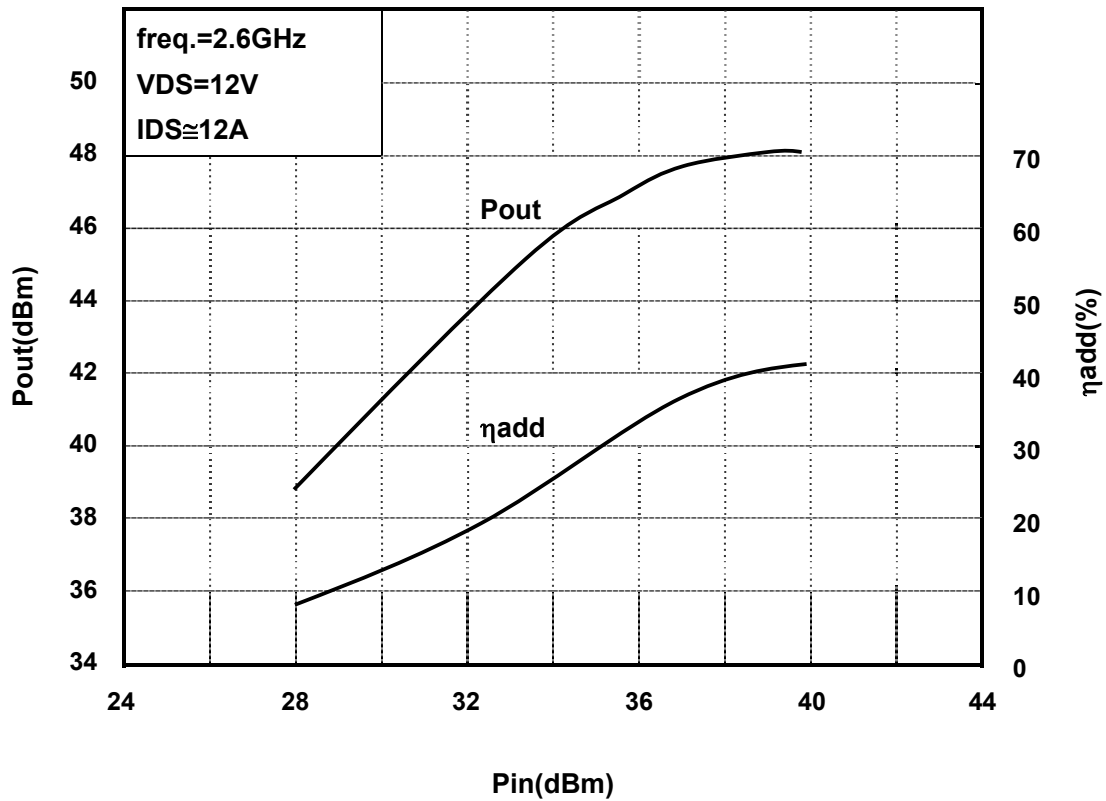

Power Dissipation(PT) vs. Case Temperature(Tc)

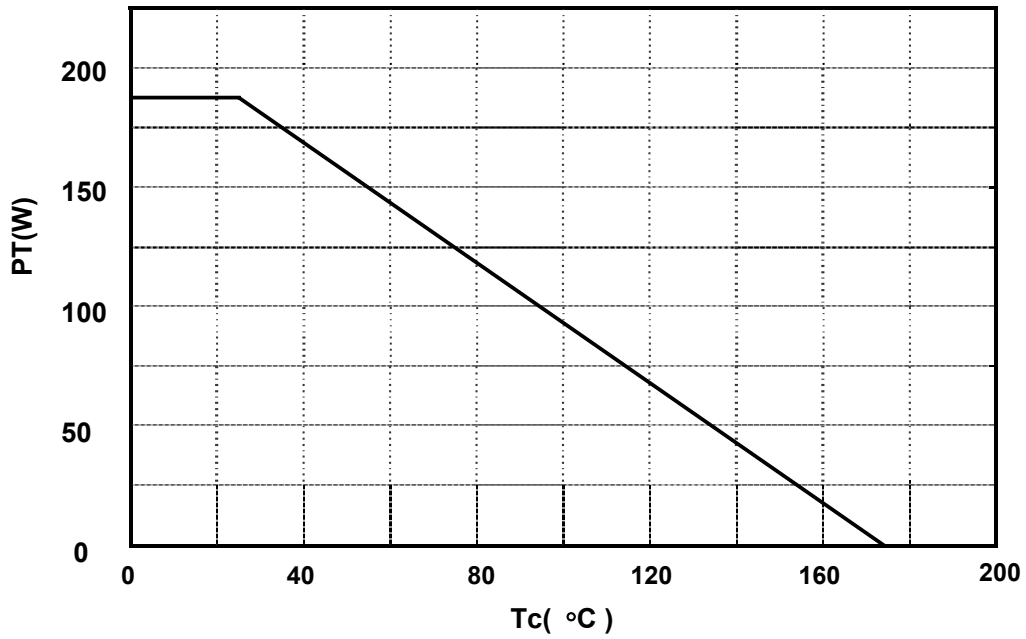

DRAWING OF RECOMMENDABLE MATCHING NETWORK

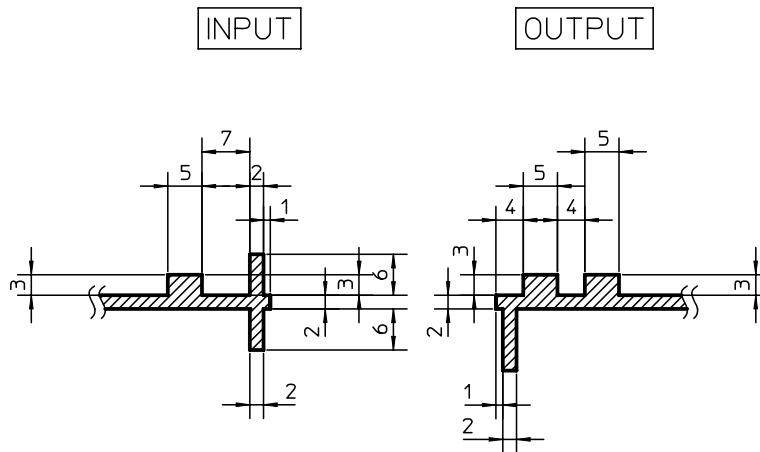

Unit: mm

Substrate Material: Teflon ($\epsilon_r=2.8$)

Thickness: 0.76mm