

DC MOTOR PULSE WIDTH MODULATOR

DESCRIPTION

The SG1731 is a pulse width modulator circuit designed specifically for DC motor control. It provides a bi-directional pulse train output in response to the magnitude and polarity of an analog error signal input. The device is useful as the control element in motor-driven servo systems for precision positioning and speed control, as well as in audio modulators and amplifiers using carrier frequencies to 350 KHz.

The circuit contains a triangle waveform oscillator, a wideband operational amplifier for error voltage generation, a summing/scaling network for level-shifting the triangle waveform, externally programmable PWM comparators and dual $\pm 100\text{mA}$, $\pm 22\text{V}$ totem pole drivers with commutation diodes for full bridge output. A SHUTDOWN terminal forces the drivers into a floating high-impedance state when driven LOW. Supply voltage to the control circuitry and to the output drivers may be from either dual positive and negative supplies, or single-ended.

FEATURES

- $\pm 3.5\text{V}$ to $\pm 15\text{V}$ control supply
- $\pm 2.5\text{V}$ to $\pm 22\text{V}$ driver supply
- Dual 100mA source/sink output drivers
- 5KHz to 350KHz oscillator range
- High slew rate error amplifier
- Adjustable deadband operation
- Digital SHUTDOWN input

HIGH RELIABILITY FEATURES - SG1731

- ◆ Available to MIL-STD-883
- ◆ LMI level "S" processing available

BLOCK DIAGRAM

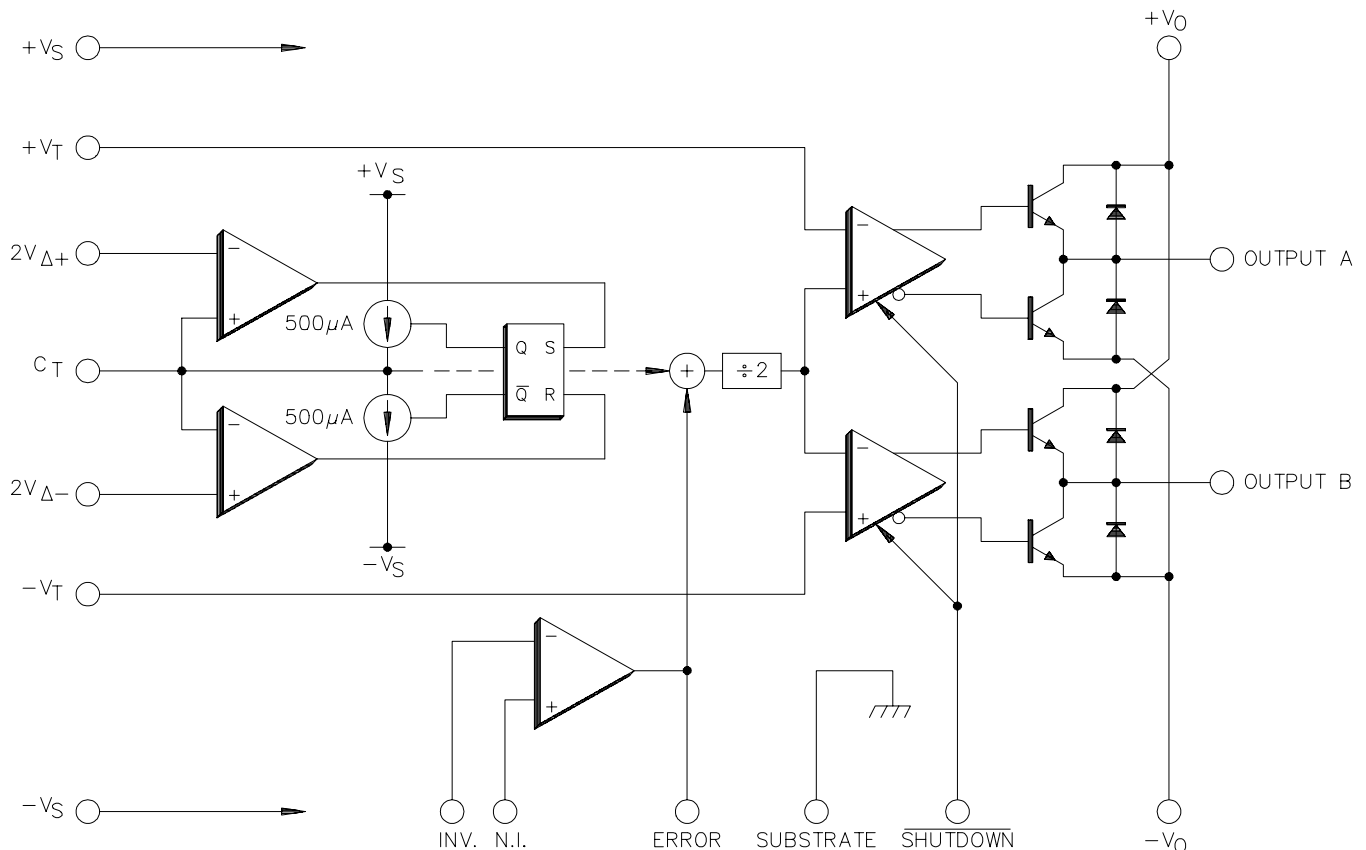

ABSOLUTE MAXIMUM RATINGS (Note1)

Supply Voltage ($\pm V_S$)	$\pm 18V$	Output Driver Diode Current (continuous)	200mA
Analog Inputs	$\pm V_S$	Output Driver Diode Current (peak, 500ns)	400mA
Digital Inputs (SHUTDOWN)	$-V_S-0.3V$ to $-V_S+18V$	Operating Junction Temperature	
Output Driver Supply Voltage ($\pm V_O$)	$\pm 25V$	Hermetic (J - Package)	150°C
Source/Sink Output Current (continuous)	200mA	Plastic (N - Package)	150°C
Source/Sink Output Current (peak, 500ns)	400mA	Storage Temperature Range	-65°C to 150°C
Note 1. Values beyond which damage may occur.		Lead Temperature (Soldering, 10 Seconds)	300°C

THERMAL DATA

J Package:

Thermal Resistance-Junction to Case, θ_{JC}	30°C/W
Thermal Resistance-Junction to Ambient, θ_{JA}	80°C/W

N Package:

Thermal Resistance-Junction to Case, θ_{JC}	40°C/W
Thermal Resistance-Junction to Ambient, θ_{JA}	65°C/W

Note A. Junction Temperature Calculation: $T_J = T_A + (P_D \times \theta_{JA})$.

Note B. The above numbers for θ_{JC} are maximums for the limiting thermal resistance of the package in a standard mounting configuration. The θ_{JA} numbers are meant to be guidelines for the thermal performance of the device/pc-board system. All of the above assume no ambient airflow.

RECOMMENDED OPERATING CONDITIONS (Note 2)

Supply Voltage Range ($\pm V_S$)	$\pm 3.5V$ to $\pm 15V$	Oscillator Frequency Range	10Hz to 350KHz
Error Amp Common-Mode Range	$-V_S + 3V$ to $V_S - 3V$	Oscillator Voltage (Peak-to-Peak)	1V to 10V
Output Driver Supply Voltage Range	$\pm 2.5V$ to $\pm 22V$	Oscillator Timing Capacitor (C_T)	200pF to 2.5 μ F
Source/Sink Output Current (continuous)	100mA	Operating Ambient Temperature Range	
Source/Sink Output Current (peak, 500ns)	200mA	SG1731	-55°C to 125°C
Output Driver Diode Current (continuous)	100mA	SG2731	-25°C to 85°C
Output Driver Diode Current (peak, 500ns)	200mA	SG3731	0°C to 70°C

Note 2. Range over which the device is functional and parameter limits are guaranteed.

ELECTRICAL CHARACTERISTICS

(Unless otherwise specified, these specifications apply over the operating ambient temperatures for SG1731 with $-55^\circ\text{C} \leq T_A \leq 125^\circ\text{C}$, SG2731 with $-25^\circ\text{C} \leq T_A \leq 85^\circ\text{C}$, SG3731 with $0^\circ\text{C} \leq T_A \leq 70^\circ\text{C}$, $V_S = \pm 15V$, and $V_O = \pm 22V$. Low duty cycle pulse testing techniques are used which maintains junction and case temperatures equal to the ambient temperature.)

Parameter	Test Conditions	SG1731/2731/3731			Units
		Min.	Typ.	Max.	
Oscillator Section					
C_T Charging Current	$T_A = 25^\circ\text{C}$	450	500	550	μA
	$T_A = T_{\text{MIN}}$ to T_{MAX}	400		600	μA
$2V_{\Delta\pm}$ Input Bias Current	$V_{\text{CM}} = \pm 5V$			-20	μA
Initial Oscillator Frequency	$C_T = 1000\text{pF}$, $2V_{\Delta\pm} = \pm 5V$, $T_A = 25^\circ\text{C}$	22.5	25.0	27.5	KHz
Temperature Stability (Note 3)	$C_T = 1000\text{pF}$, $2V_{\Delta\pm} = \pm 5V$			10	%
Error Amplifier Section (Note 5)					
Input Offset Voltage				10	mV
Input Bias Current				3	μA
Input Offset Current				600	nA
Open Loop Voltage Gain	$R_L = 2K\Omega$	70			dB
Output Voltage Swing	$R_L = 2K\Omega$	± 10			V
Common-Mode Rejection Ratio		70			dB
Slew Rate (Notes 3 and 4)	$T_A = 25^\circ\text{C}$	5	10		V/ μs
Unity Gain Bandwidth (Notes 3 and 4)	$T_A = 25^\circ\text{C}$	0.7	1		MHz
PWM Comparators					
Input Bias Current	$\pm V_T = \pm 3V$			6	μA

ELECTRICAL CHARACTERISTICS (continued)

Parameter	Test Conditions	SG1731/2731/3731			Units
		Min.	Typ.	Max.	
SHUTDOWN Section					
Logic Threshold	$-V_S = -3.5V$ to $-15V$	$V_S+0.8$		$V_S+2.0$	V
SHUTDOWN HIGH Current	$V_{SHUTDOWN} = -V_S+2.4V$			400	μA
SHUTDOWN LOW Current	$V_{SHUTDOWN} = -V_S$			-1.0	mA
Output Drivers (Each Output)					
HIGH Output Voltage	$I_{SOURCE} = 20mA$	19.2			V
	$I_{SOURCE} = 100mA$	19.0			V
LOW Output Voltage	$I_{SINK} = 20mA$			-19.2	V
	$I_{SINK} = 100mA$			-19.0	V
Driver Risetime	$C_L = 1000pF$			300	ns
Driver Falltime	$C_L = 1000pF$			300	ns
Total Supply Current					
V_S Supply Current	$V_{SHUTDOWN} = -V_S + 0.8V$			14	mA
V_O Supply Current	$V_{SHUTDOWN} = -V_S + 0.8V$			6	mA

Note 3. These parameters, although guaranteed, are not tested in production.
 Note 4. Unity Gain Inverting 10K Ω Feedback Resistance.

Note 5. $V_{CM} = \pm 12V$.

APPLICATION INFORMATION

SUPPLY VOLTAGE

The SG1731 requires a supply voltage for the control circuitry (V_S) and for the power output drivers (V_O). Each supply may be either balanced positive and negative with respect to ground, or single-ended. The only restrictions are:

1. The voltage between $+V_S$ and $-V_S$ must be at least 7.0V; but no more than 44V.
2. The voltage between $+V_O$ and $-V_O$ must be at least 5.0V; but no more than 44V.
3. $+V_O$ must be at least 5V more positive than $-V_S$. This eliminates the combination of a single-ended positive control supply with a single-ended negative driver supply.

SUBSTRATE CONNECTION

The substrate connection (Pin 10) must always be connected to either $-V_S$ or $-V_O$, whichever is more negative. The substrate must also be well bypassed to ground with a high quality capacitor.

OSCILLATOR

The triangle oscillator consists of two voltage comparators, a set/reset flip-flop, a bi-directional 500 μA current source, and an external timing capacitor C_T . A positive reference voltage ($2V_{\Delta+}$) applied to Pin 2 determines the positive peak value of the triangle, and a negative reference voltage ($2V_{\Delta-}$) at Pin 7 sets the negative peak value of the triangle waveform.

Since the value of the internal current source is fixed at a nominal $\pm 500\mu A$, the oscillator period is a function of the selected peak-to-peak voltage excursion and the value of C_T . The theoretical expression for the oscillator period is:

$$T_{osc} = \frac{2C_T dV}{5 \times 10^{-4}} \quad (\text{Eq.1})$$

where C_T is the timing capacitor in Farads and dV is V_{osc} in Volts peak-to-peak.

As a design aid, the solutions to Equation 1 over the recommended range of T_{osc} and V_{osc} are given in graphic form in Figure 1. The lower limit on T_{osc} is 1.85 μs , corresponding to a maximum frequency of 350 KHz. The maximum value of V_{osc} , ($2V_{\Delta+}$) - ($2V_{\Delta-}$), is 10V peak-to-peak for linear waveforms.

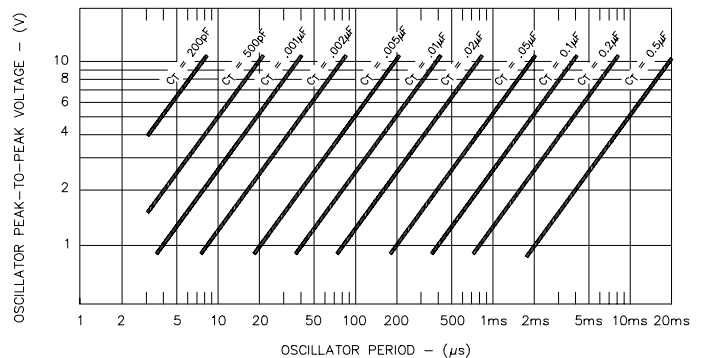

FIGURE 1 - SG1731 OSCILLATOR PERIOD VS. V_{osc} AND C_T

ERROR AMPLIFIER

The error amplifier of the SG1731 is a conventional internally-compensated operational amplifier with low output impedance. All of the usual feedback and frequency compensation techniques may be used to control the closed-loop gain characteristics. The control supply voltage $\pm V_S$ will determine the input common mode range and output voltage swing; both will extend to within 3V of the V_S supply.

PULSE WIDTH MODULATION

Pulse width modulation occurs by comparing the triangle waveform to a fixed upper ($+V_T$) and lower ($-V_T$) threshold voltage. A crossing above the upper threshold causes Output A to switch to the HIGH state, and a crossing below

APPLICATION INFORMATION (continued)

the lower threshold causes Output B to switch to the HIGH state. If $\pm V_S$ is less than $\pm 8V$ then $\pm V_T$ can be obtained with resistors from $\pm V_S$. If $\pm V_S$ is greater than $\pm 8V$ use zeners.

Threshold crossings are generated by shifting the triangle waveform up and down with the error voltage (Pin 5). A positive error voltage will result in a pulse width modulated output at Driver A (Pin 13). Similarly, a negative error voltage produces a pulse train at Driver B (Pin 12). Figure 2 illustrates this process for the case where $V_{\Delta+}$ is greater than V_T .

It is important to note that the triangle shifting circuit also attenuates the waveform seen at C_T by a factor of 2. This results in a waveform at the PWM comparators with a positive peak of $V_{\Delta+}$ and a negative peak of $V_{\Delta-}$, and must be taken into account when selecting the values for $+V_T$ and $-V_T$.

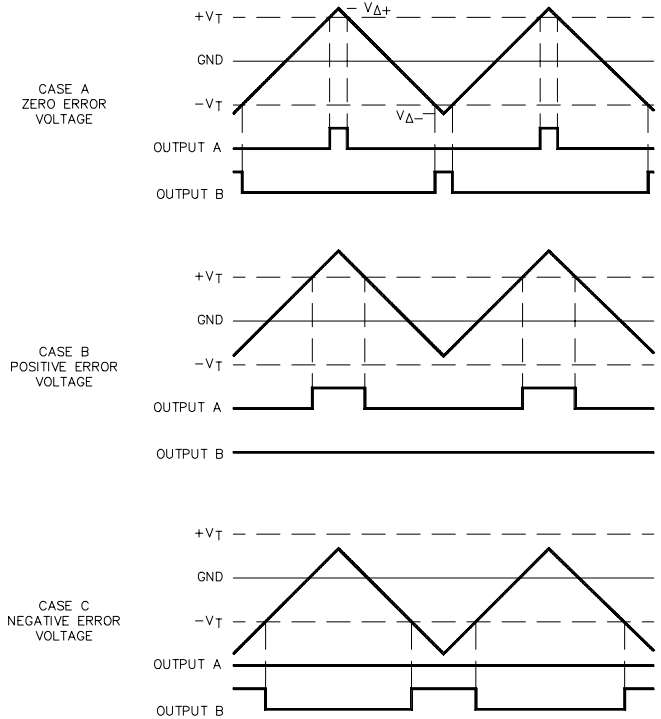

FIGURE 2 - PULSE WIDTH MODULATION WITH NO DEADBAND

APPLICATION CIRCUITS

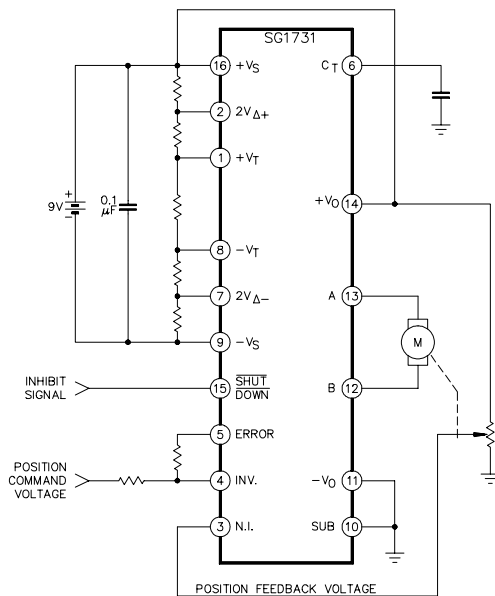

FIGURE 3

In this simple battery-powered position servo, the control supply and driver supply are both single-ended positive with respect to ground.

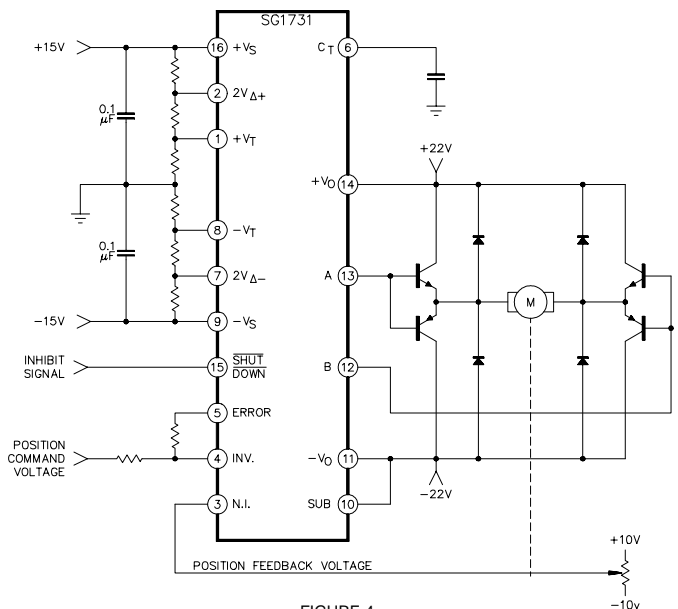

FIGURE 4

A high torque position servo is obtained by buffering the output drivers to obtain higher output current.

APPLICATION CIRCUITS

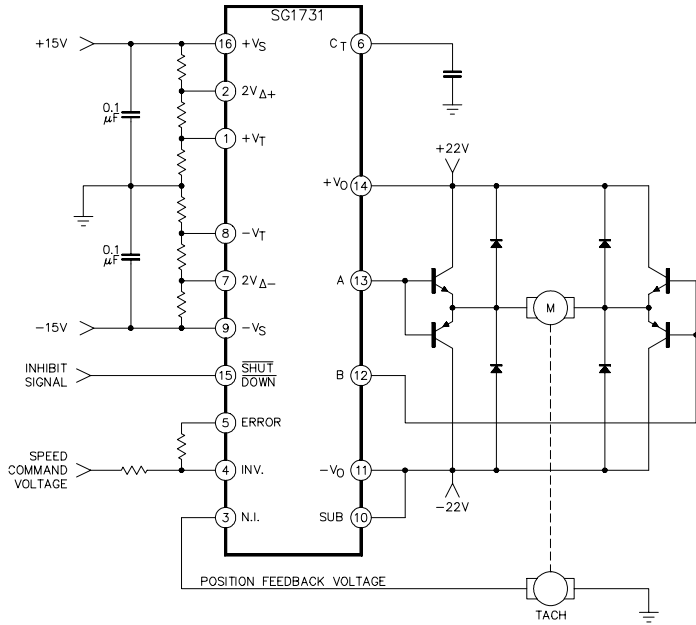

FIGURE 5

Bi-directional speed control results when the feedback voltage transducer is a tachometer.

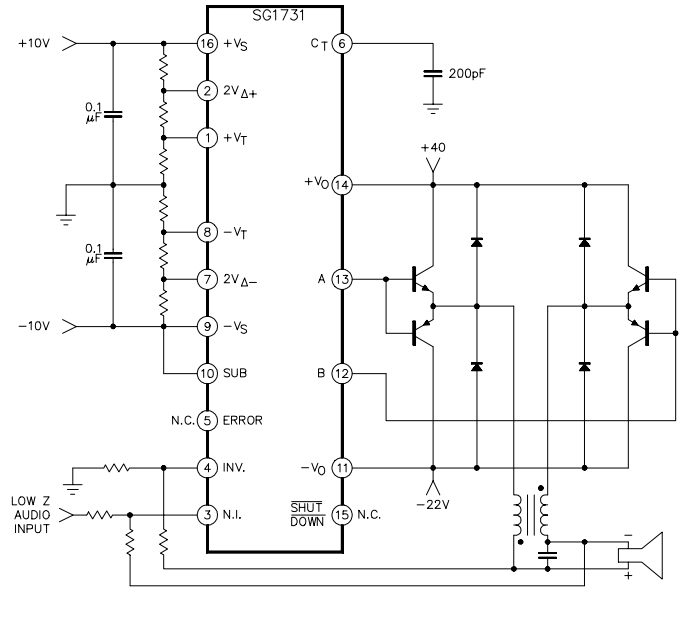

FIGURE 6

The two-quadrant transfer function of the SG1731 is ideal for pulse width modulated audio power amplifiers.

CONNECTION DIAGRAMS & ORDERING INFORMATION (See Note Below)

Package	Part No.	Ambient Temperature Range	Connection Diagram
16-PIN CERAMIC DIP J - PACKAGE	SG1731J/883B	-55°C to 125°C	
	SG1731J	-55°C to 125°C	
	SG2731J	-25°C to 85°C	
	SG3731J	0°C to 65°C	
16-PIN PLASTIC DIP N - PACKAGE	SG2731N	-25°C to 85°C	
	SG3731N	0°C to 65°C	

Note 1. All packages are viewed from the top.

Note 2. Contact factory for flatpack and leadless chip carrier availability.