

T B 3 1 2 1 3 F N G

PLL FREQUENCY SYNTHESIZER FOR CORDLESS TELEPHONE

FEATURES

- One packaging PLL, VCO and 1st MIX
- Low operating voltage : $V_{CC} = 2.0 \sim 5.5V$
($T_a \geq -10^\circ C$, $V_{CC} = 1.9 \sim 5.5V$)
- Low current consumption : $I_{CC} = 16mA$ (Typ.)
- Charge pump is constant current type, and is able to change output current by serial data
- Reference oscillation circuit is adopted circuit of bipolar, so getting the stable X'tal oscillation circuit
- Available standby control for receiver and transmitter independent of each other
- Small package : SSOP24pin (0.65mm pitch)

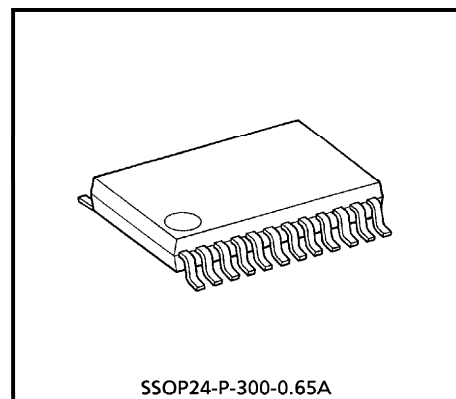

Weight : 0.14g (Typ.)

Handle with care to prevent devices deterioration by static electricity.

BLOCK DIAGRAM

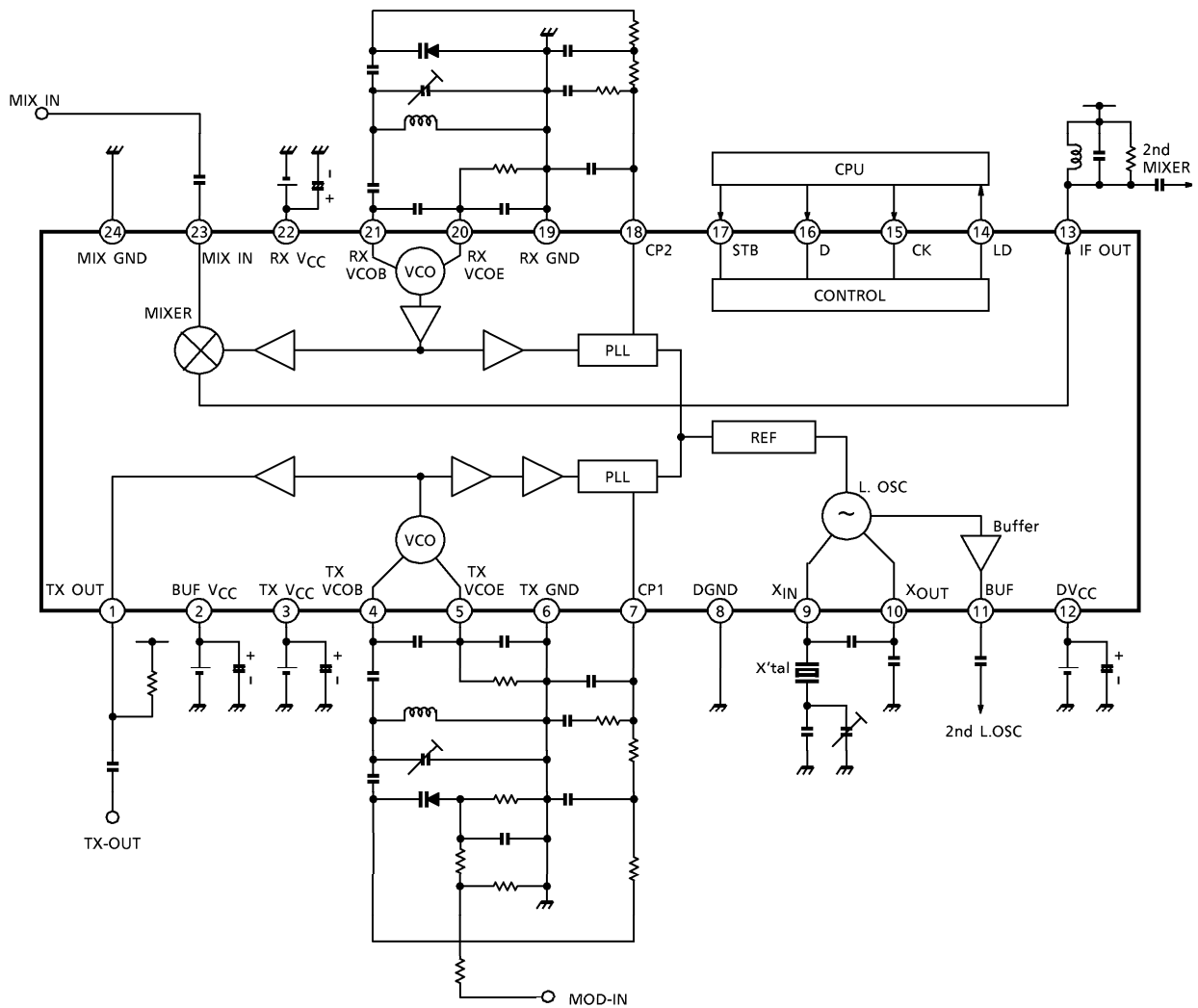

PIN FUNCTION

PIN No.	PIN NAME	FUNCTION	INTERNAL EQUIVALENT CIRCUIT
1	TX OUT	Output terminal of RF.	
2	BUF VCC	Power supply of transmitter output, transmitter VCO.	
3	TX VCC	Power supply for transmitter PLL.	
4	TX VCOB	Base terminal of transistor for transmitter VCO.	
5	TX VCOE	Emitter terminal of transistor for transmitter VCO.	
6	TX GND	GND terminal for transmitter.	
7	CP1	Output terminal of charge pump for transmitter. It is constant current output type, and output current is varied by input serial data.	
8	DGND	GND terminal of PLL.	
9	X _{IN}	Input terminal of local oscillation. In case of external input, connecting it to this terminal.	
10	X _{OUT}	Output terminal of local oscillation.	
11	BUF	Output terminal of BUFFER AMP. The signal of local oscillation is output through BUFFER AMP.	
12	DVCC	Power supply of PLL.	

PIN No.	PIN NAME	FUNCTION	INTERNAL EQUIVALENT CIRCUIT
13	IF OUT	MIX output terminal. For open collector output.	
14	LD	Output terminal of lock detector.	
15	CK	Input terminal of clock.	<p>Input the serial data to control this IC.</p>
16	D	Input terminal of data.	
17	STB	Input terminal of strobe signal.	
18	CP2	Output terminal of charge pump for receiver. It is constant current output type, and output current is varied by input serial data.	
19	RX GND	GND terminal for receiver.	
20	RX VCOE	Emitter terminal of transistor for receiver VCO.	
21	RX VCOB	Base terminal of transistor for receiver VCO.	
22	RX VCC	Power supply for receiver.	
23	MIX IN	Input terminal of MIX.	
24	MIX GND	GND terminal of MIX.	

DESCRIPTION OF FUNCTION AND OPERATION

1. Entry of serial data

- Serial data used to control the IC is input through three terminals, CK, D and STB.
 - ① During the rise of a clock pulse, data is fed to the shift register in the IC in order from the LSB.
 - ② Upon the reception of all data, the strobe signal (STB) is made "H".
 - ③ After the reception of a strobe signal (STB) of the "H" level, the data stored in the shift register is transferred to the latch in the block selected by the group code, whereby the IC is controlled.
 - ④ A counters start to operate after the reception of a strobe signal (STB) of the "L" level.
 - The three terminal, CK, D and STB, contains Schmitt trigger circuits to prevent the data errors by noise, etc.
- Serial data group and group code
- The IC has control divided into four groups so that they may be controlled independent of one another. Each group is identified by a 2bit group code attached at the data end.

CODE	ITEM
10	Number of divisions by TX programmable divider
01	Number of divisions by RX programmable divider
11	Number of divisions by reference divider (X_{IN})
00	Optional control

○ Serial data input timing

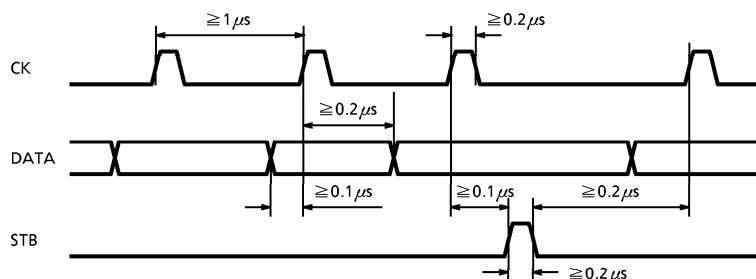

2. Programmable dividers (TX, RX)

- These programmable dividers are composed of a 5bit swallow counter (5bit programmable divider), a 12bit programmable counter, and a two-modular prescaler providing 64 and 66 divisions.
- Swallow counter system is adopted to set high reference frequency.
- Sending certain data to the swallow counter and the programmable counter allows the setting of any of 1984 to 262142 divisions (multiple of two).
- The programmable counter and swallow counter are set by each channel. Each channel is specified by a group code.

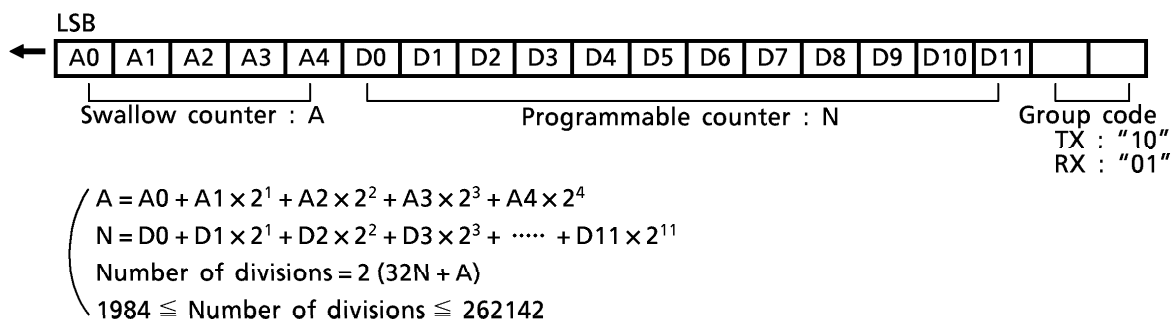

3. Reference divider

- This block generates the reference frequency for the PLL.
- The reference divider is composed of a 12bit reference divider and a half fixed divider.
- Sending certain data to the reference divider allows the setting of any of 6 to 8190 divisions (multiple of two).

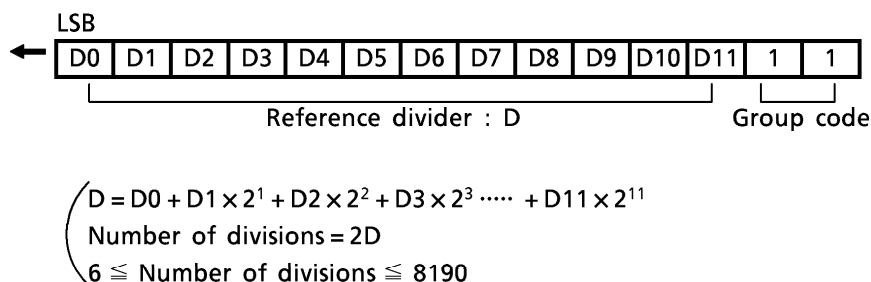

The example of setting number of divisions

In case of

Reference frequency : 21.25MHz
 Start VCO frequency : 380.2125MHz
 Channel step : 12.5KHz

- Set up phase comparator frequency

Since a programmable divider is multiple of two, phase comparator frequency is set a half of frequency step.

$$\text{Phase comparator frequency} = (12.5 \times 10^3 \div 2) = 6.25\text{KHz}$$

- Set up programmable divider divisions

$$380.2125 \times 10^6 \div (12.5 \times 10^3 \div 2) = 60834$$

$$60834 = 2(32N + A)$$

$$N = 950 \quad A = 17$$

- Set up reference divider divisions

$$21.25 \times 10^6 \div (12.5 \times 10^3 \div 2) = 3400$$

$$2D = 3400$$

$$D = 1700$$

4. Optional control

- The optional control below is available.
 - ① Test mode (Usually set up T1 = T2 = T3 = "0").
 - ② Control of the charge pump output current for each channel.
 - ③ Output terminal for Lock detector.
 - ④ Standby control of each channel.

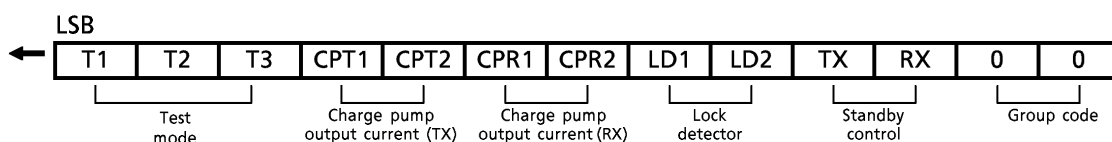

- T1, T2, T3 : Bit for test mode
- CPT1, 2 : Switchover bit for charge pump output current (TX)
- CPR1, 2 : Switchover bit for charge pump output current (RX)
- LD1, 2 : Control bit for lock detector output
- TX, RX : Standby control bit (TX, RX)

- Description of options including their control

- ① Test mode (T1, T2, T3)

Bit "T1, T2, T3" is for test mode. In other than the test mode, set this bit at "0".

- ② Control of charge pump output current (CPT, CPR)

This IC uses a constant current output type charge pump circuit. Output current is varied by controlling "CPT1, 2, CPR1, 2".

CHARGE PUMP OUTPUT CURRENT

CONTROL BIT		CHARGE PUMP OUTPUT CURRENT
CPT1	CPT2	
0	0	± 100 μ A
0	1	± 200 μ A
1	0	± 400 μ A
1	1	± 800 μ A

High speed lock up is possible by switching charge pump output current.

(Note) CPR is the similar way

- ③ Lock detector output

When phase comparator detects phase difference, LD terminal (pin 14) outputs "L". When phase comparator locks, LD terminal outputs "H". On standby, outputs "H".

LD terminal output is controlled by "TX", "RX", "LD1" and "LD2".

LD terminal output is open drain output.

CONTROL BIT		LOCK DETECTOR OUTPUT STATE
LD1	LD2	
0	0	L
0	1	RX Only detect
1	0	TX Only detect
1	1	TX * RX

{ On unlock = "L"
 On lock = "H"
 On Standby = "H"

→ Logical multiply (AND) of TX, RX

- ④ Standby control (SBT, SBR)

Available standby control for receiver and transmitter independent of each other.

CONTROL BIT		STATE		
TX	RX	TX	RX	REF
0	0	ON	ON	ON ↓
0	1	ON	OFF	
1	0	OFF	ON	
1	1	OFF	OFF	

5. Reference frequency oscillation circuit and buffer amplifier

This IC has a stable oscillation circuit composed of bipolar.

In case of inputting the external reference frequency directly, use X_{IN} terminal (pin 9).

For the common use of X'tal of the reference frequency oscillation circuit for the PLL and X'tal of local oscillation to 2'nd MIX, output terminal of local oscillation signal with buffer amplifier (pin 11) may be used.

MAXIMUM RATINGS (Ta = 25°C)

CHARACTERISTIC	SYMBOL	RATING	UNIT
Power Supply Voltage	V _{CC}	6	V
Power Dissipation	P _D	780	mW
Operating Temperature	T _{opr}	-30~85	°C
Storage Temperature	T _{stg}	-55~150	°C

ELECTRICAL CHARACTERISTICS (Unless otherwise specified, Ta = 25°C, V_{CC} = 2.2V)

CHARACTERISTIC	SYMBOL	TEST CIR-CUIT	TEST CONDITION	MIN.	TYP.	MAX.	UNIT
Operating Power Supply Voltage	V _{CC}	—	Ta = -30~+85°C	2.0	2.2	5.5	V
			Ta = -10~+85°C	1.9	2.2	5.5	
Operating Power Supply Current	I _{CCO}	1	TX, RX = ON (Open VCOE terminal)	—	16	22	mA
Waiting Current Consumption	I _{CCS}	1	TX, RX = OFF	—	950	1300	μA

PLL

Input Frequency	(RX)	FRX _{in}	4	VRX _{in} = 93dB _{μV} *1	200	—	520	MHz
	(TX)	FTX _{in}	4	VTX _{in} = 93dB _{μV} *1	200	—	520	
Input Sensitivity	(RX)	VRX _{in}	4	FRX _{in} = 200~520MHz *1	93	—	107	dB _{μV}
	(TX)	VTX _{in}	4	FTX _{in} = 200~520MHz *1	93	—	107	
Charge Pump Output Current 1		I _{CP1}	2	V _{CP} = 1.1V	—	±100	—	μA
Charge Pump Output Current 2		I _{CP2}	2	V _{CP} = 1.1V	—	±200	—	μA
Charge Pump Output Current 3		I _{CP3}	2	V _{CP} = 1.1V	—	±400	—	μA
Charge Pump Output Current 4		I _{CP4}	2	V _{CP} = 1.1V	—	±800	—	μA
Charge Pump OFF Leak Current		I _{CPOFF}	2	V _{CP} = 1.1V, Standby mode	-1	—	+1	μA
CK Input Frequency		F _{CK}	—		—	—	1.0	MHz
Input Voltage	(H)	V _{IH}	—	CK, DATA, STB each terminal	0.8 × V _{CC}	V _{CC}	5.7	V
	(L)	V _{IL}	—	CK, DATA, STB each terminal	-0.2	0	0.2 × V _{CC}	
Input Current	(H)	I _{IH}	—	CK, DATA, STB each terminal V _{IH} = 6V	—	—	1	μA
	(L)	I _{IL}	—	CK, DATA, STB each terminal V _{IL} = 6V	—	—	1	
LD Terminal Resistance ON		R _{LD}	3	LD = "L"	—	500	—	Ω
LD Terminal OFF Leak Current		I _{LDOFF}	—		-1	—	+1	μA

REF

CHARACTERISTIC	SYMBOL	TEST CIRCUIT	TEST CONDITION	MIN.	TYP.	MAX.	UNIT
XIN Operating Frequency	FX _{in}	5	VX _{in} = 105dB μ V Sin-wave	5	21.25	25	MHz
XIN Input Level	VX _{in}	5	FX _{in} = 21.25MHz	102	105	112	dB μ V

1st MIX

Operating Input Frequency	FMIX	6		200	—	520	MHz
MIX Conversion Gain	GVMIX	6	Input 50 Ω , Load : Output 750 Ω	15	18	22	dB
3rd Intercept Point	IP3	—		—	108	—	dB μ V
1dB Compression Level	1dBCP	6		—	99	—	dB μ V

REFERENCE VALUE

Input/output resistance, input/output capacitance (Typ.)

PIN No.	PIN NAME	RESISTANCE (Ω)	CAPACITANCE (pF)
23	MIX IN	620	3.1
13	IF OUT	11K	2.5

RECEIVER VCO

Operating Frequency	FRVCO	—		200	—	520	MHz
C/N Characteristic	CNR	—	PLL loop shaping *2	—	72	—	dB

TRANSMITTER VCO

Operating Frequency	FTVCO	—		200	—	520	MHz
C/N Characteristic	CNT	—	PLL loop shaping *2	—	72	—	dB

*1 : In case of input 50 Ω from VCOE terminal

*2 : Detuning frequency = 12.5kHz, Band range = 8kHz

*3 : Use for operating TX V_{CC}-PLL V_{CC}, RX V_{CC}-PLL V_{CC} is within $\pm 0.2V$.

TEST CIRCUIT

1. I_{CC0} , I_{CCS}

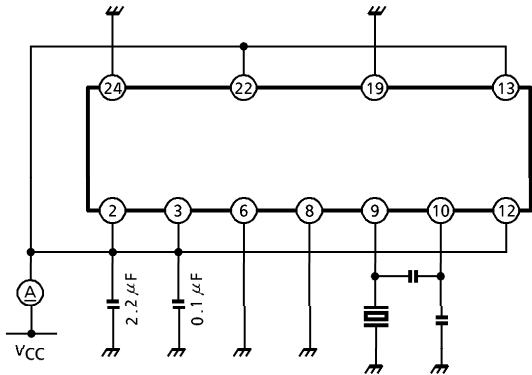

2. I_{CP}

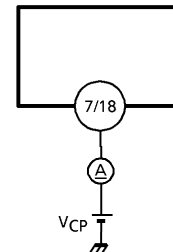

3. R_{LD}

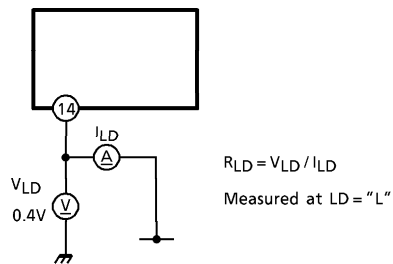

4. V_{TXIN} , V_{XIN}

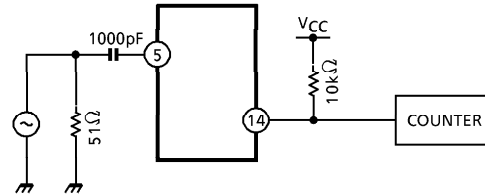

5. V_{XIN}

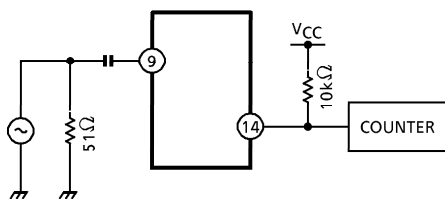

6. G_{VMIX}

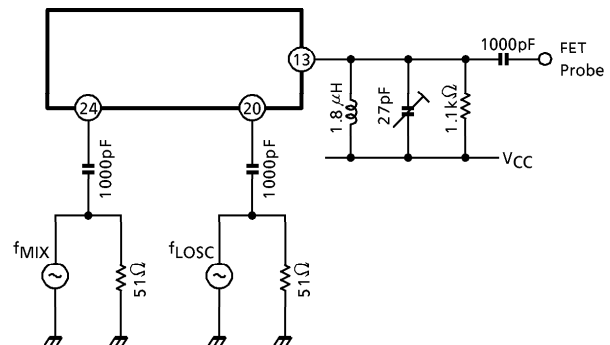

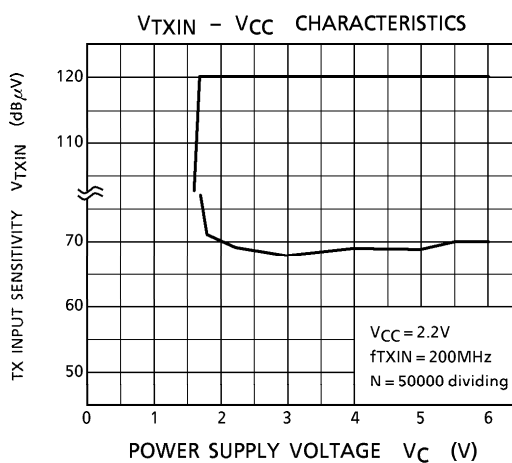
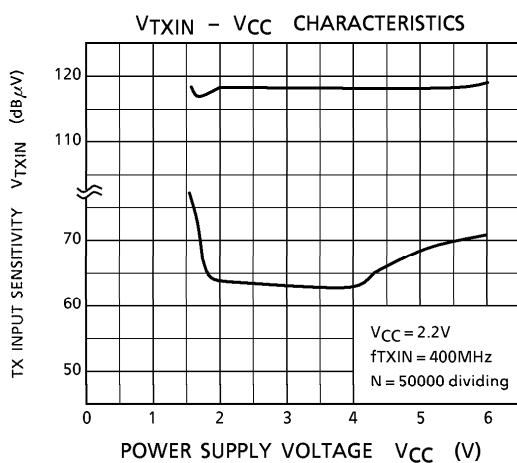
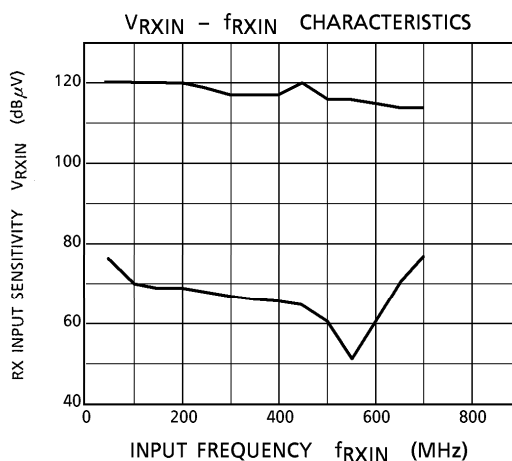
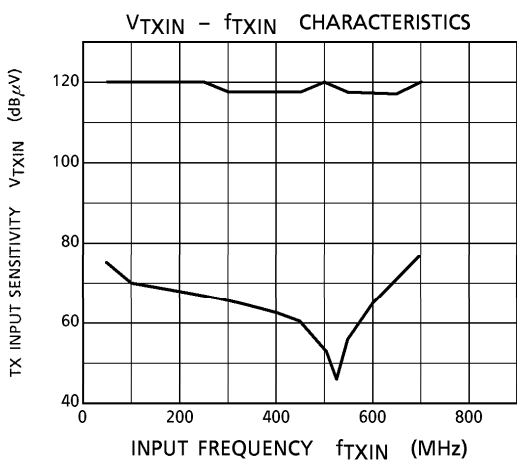
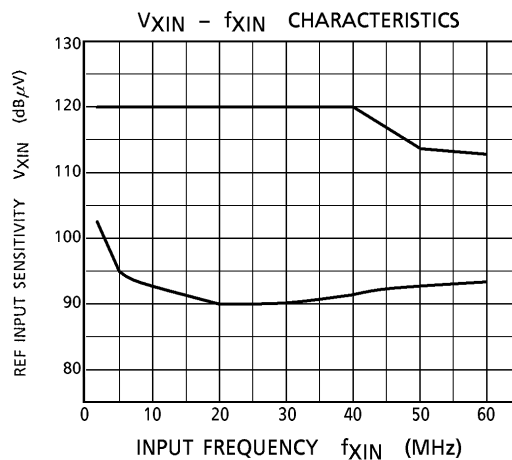
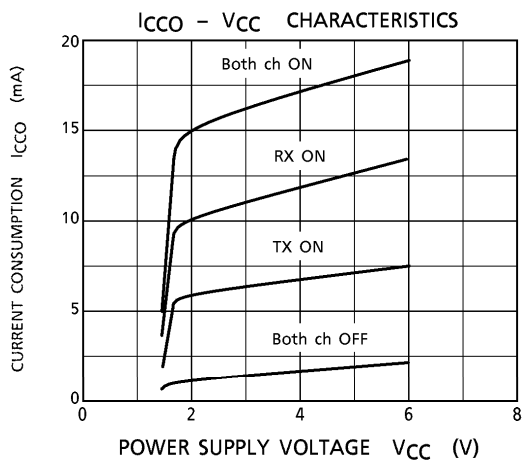

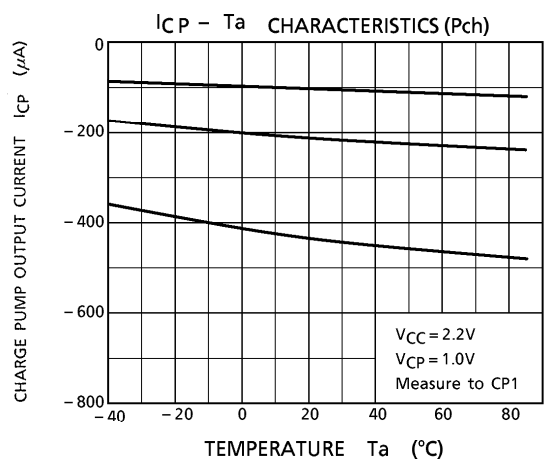
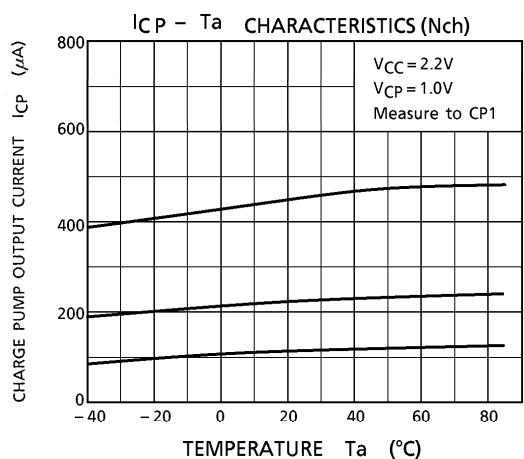
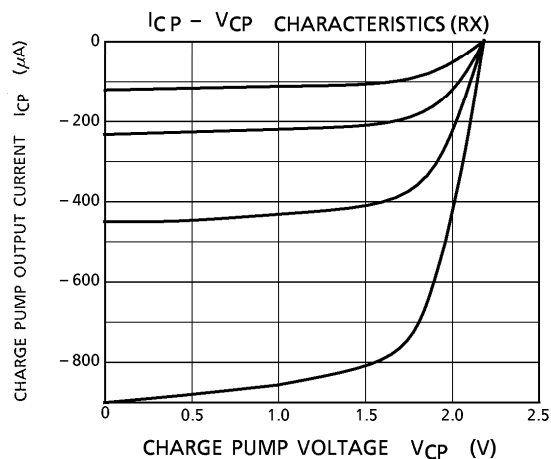
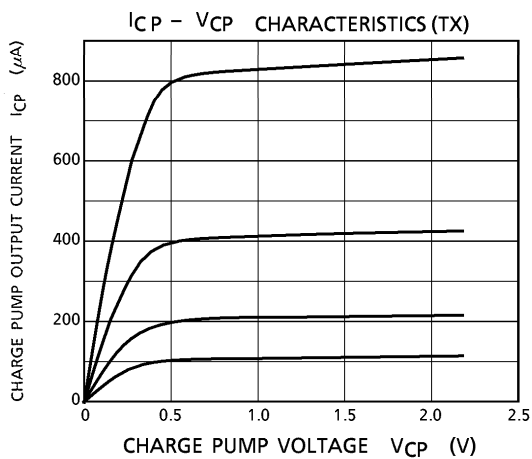
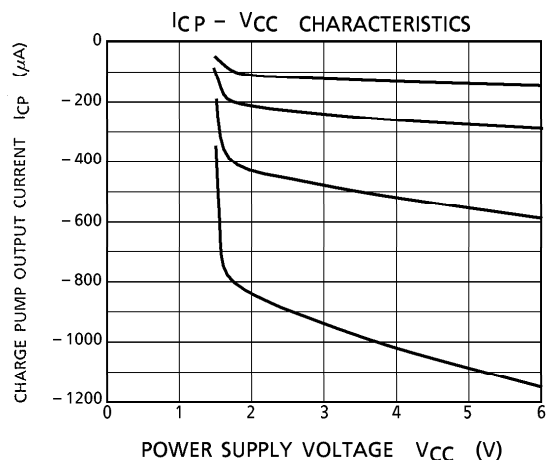
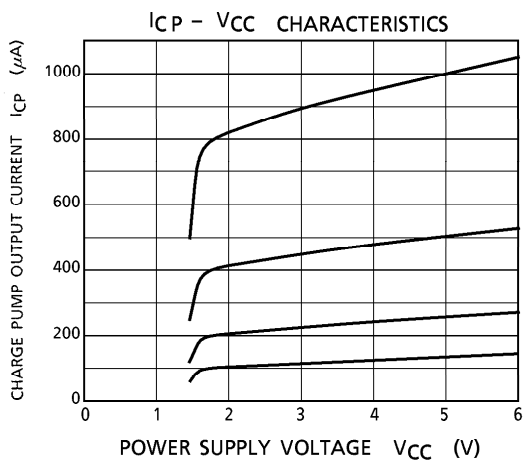

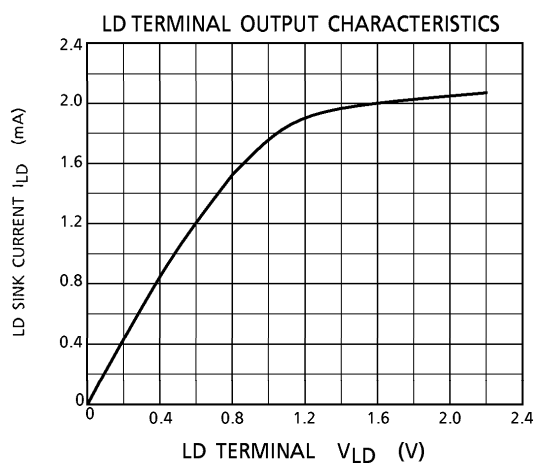
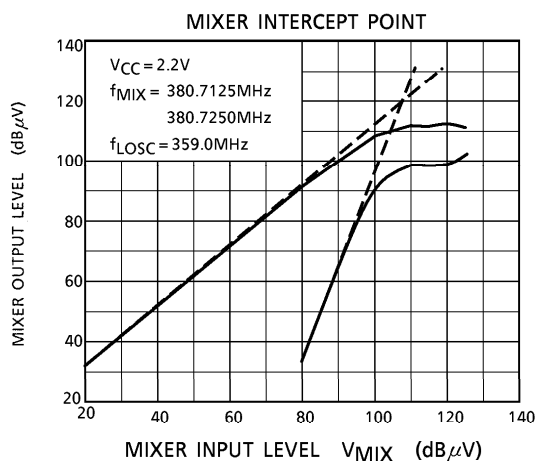
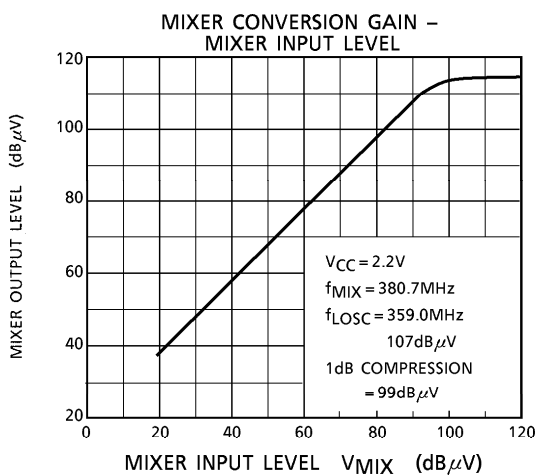
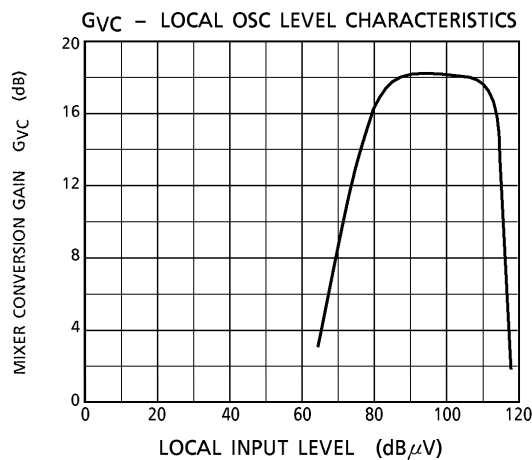
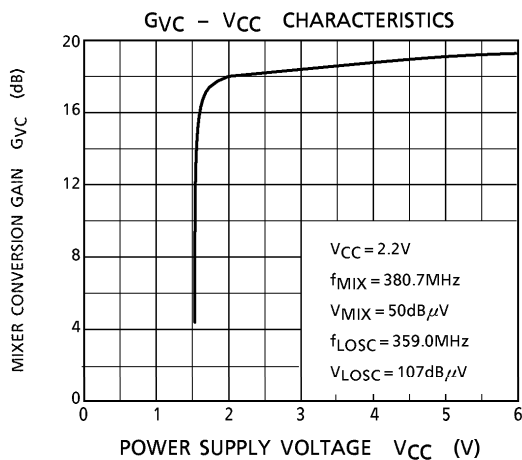

APPLICATION CIRCUIT

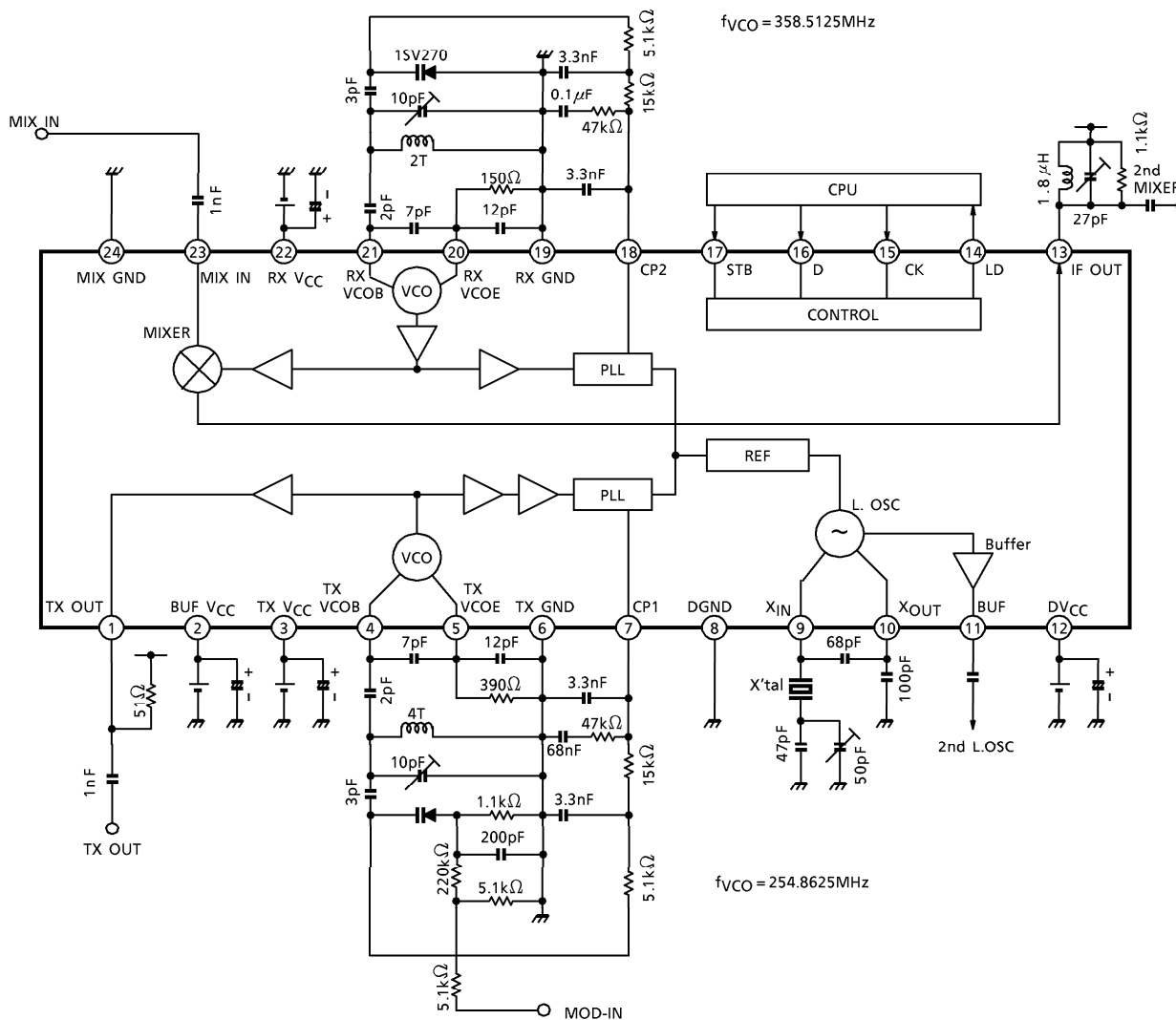

Hand set of cordless phone $V_{CC} = 2.2\text{ [V] constant}$

PACKAGE DIMENSIONS
SSOP24-P-300-0.65A

UNIT : mm

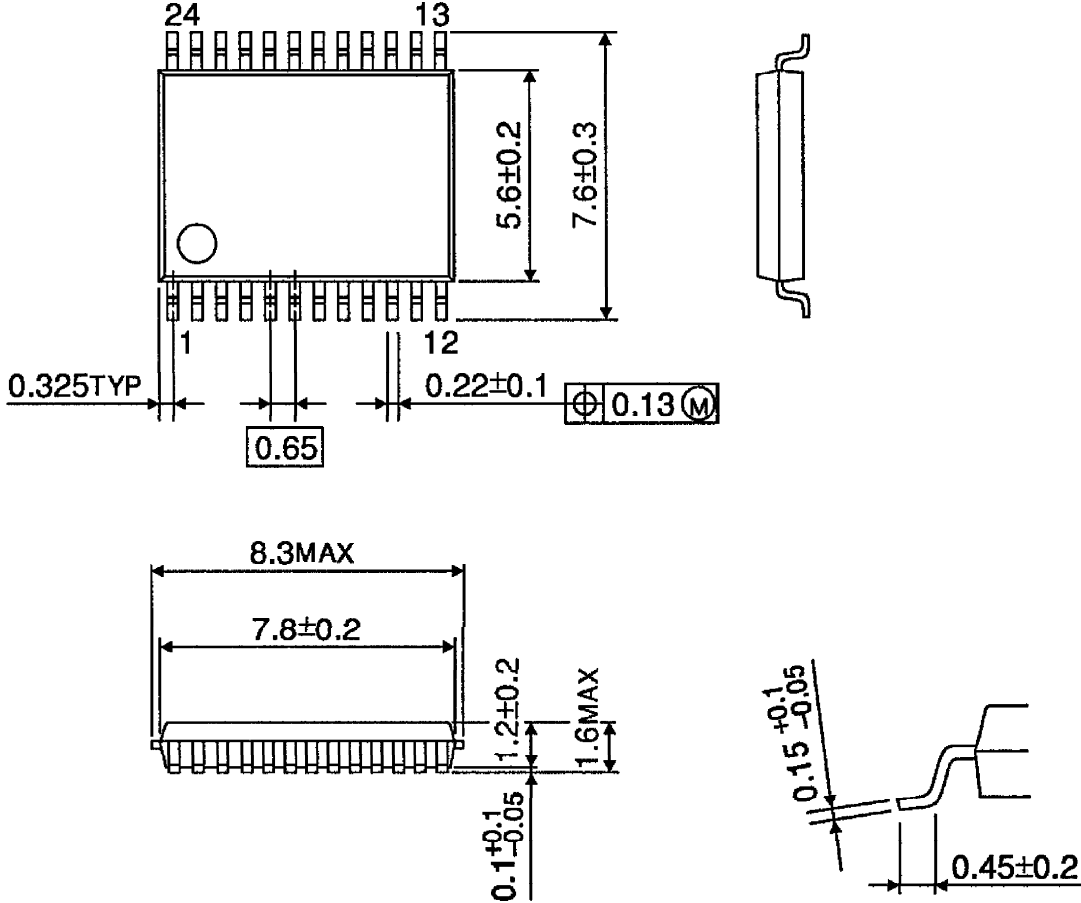

Weight : 0.14g (Typ.)

RESTRICTIONS ON PRODUCT USE

000707EBA

- TOSHIBA is continually working to improve the quality and reliability of its products. Nevertheless, semiconductor devices in general can malfunction or fail due to their inherent electrical sensitivity and vulnerability to physical stress. It is the responsibility of the buyer, when utilizing TOSHIBA products, to comply with the standards of safety in making a safe design for the entire system, and to avoid situations in which a malfunction or failure of such TOSHIBA products could cause loss of human life, bodily injury or damage to property. In developing your designs, please ensure that TOSHIBA products are used within specified operating ranges as set forth in the most recent TOSHIBA products specifications. Also, please keep in mind the precautions and conditions set forth in the "Handling Guide for Semiconductor Devices," or "TOSHIBA Semiconductor Reliability Handbook" etc..
- The TOSHIBA products listed in this document are intended for usage in general electronics applications (computer, personal equipment, office equipment, measuring equipment, industrial robotics, domestic appliances, etc.). These TOSHIBA products are neither intended nor warranted for usage in equipment that requires extraordinarily high quality and/or reliability or a malfunction or failure of which may cause loss of human life or bodily injury ("Unintended Usage"). Unintended Usage include atomic energy control instruments, airplane or spaceship instruments, transportation instruments, traffic signal instruments, combustion control instruments, medical instruments, all types of safety devices, etc.. Unintended Usage of TOSHIBA products listed in this document shall be made at the customer's own risk.
- The products described in this document are subject to the foreign exchange and foreign trade laws.
- The information contained herein is presented only as a guide for the applications of our products. No responsibility is assumed by TOSHIBA CORPORATION for any infringements of intellectual property or other rights of the third parties which may result from its use. No license is granted by implication or otherwise under any intellectual property or other rights of TOSHIBA CORPORATION or others.
- The information contained herein is subject to change without notice.