

## DNR120-480 Series



- Up to 90% Efficiency
- Wide Adjustment Range
- Parallel Function
- DC Standby Versions
- Full Power to +60 °C
- Connector Options
- 3 Year Warranty

## Specification

## Input

Input Voltage	<ul style="list-style-type: none"> <li>• 93-132/186-264 VAC, auto select, 210-370 VDC (DNR120AS, DNR240PS)</li> <li>• 90-264 VAC, 120-370 VDC (DNR480PS)</li> </ul>
Input Frequency	<ul style="list-style-type: none"> <li>• 47-63 Hz</li> </ul>
Inrush Current	<ul style="list-style-type: none"> <li>• 24/48 A at 115/230 VAC (DNR120)</li> <li>• 30/60 A at 115/230 VAC (DNR240)</li> <li>• 25/50 A at 115/230 VAC (DNR480)</li> </ul>
Power Factor	<ul style="list-style-type: none"> <li>• Meets EN61000-3-2 for class A equipment</li> </ul>
Earth Leakage Current	<ul style="list-style-type: none"> <li>• 0.8 mA max</li> </ul>
Input Protection	<ul style="list-style-type: none"> <li>• T4A, 250 VAC (DNR120)</li> <li>• T6.3A, 250 VAC (DNR240)</li> <li>• T10A, 250 VAC (DNR480)</li> </ul>

## Output

Output Voltage	<ul style="list-style-type: none"> <li>• See tables</li> </ul>
Output Voltage Trim	<ul style="list-style-type: none"> <li>• See tables</li> </ul>
Initial Set Accuracy	<ul style="list-style-type: none"> <li>• <math>\pm 1\%</math></li> </ul>
Minimum Load	<ul style="list-style-type: none"> <li>• No minimum load required</li> </ul>
Start Up Delay	<ul style="list-style-type: none"> <li>• &lt;1000 ms (may increase at low temperature extremes)</li> </ul>
Start Up Rise Time	<ul style="list-style-type: none"> <li>• &lt;150 ms</li> </ul>
Hold Up Time	<ul style="list-style-type: none"> <li>• 25/30 ms at 115/230 VAC (DNR120, DNR240)</li> <li>• 30 ms at 115/230 VAC (DNR480)</li> </ul>
Line Regulation	<ul style="list-style-type: none"> <li>• <math>\pm 0.5\%</math> max</li> </ul>
Load Regulation	<ul style="list-style-type: none"> <li>• <math>\pm 1\%</math> (<math>\pm 5\%</math> for units in parallel)</li> </ul>
Parallel Operation	<ul style="list-style-type: none"> <li>• A maximum of 3 units can be paralleled. Total power available is 90% of the rated current of each unit. Redundancy module available for load currents up to 10 A, contact sales.</li> </ul>
Transient Response	<ul style="list-style-type: none"> <li>• 4% max deviation recovering to within 1% in 1 ms for a 50% load change</li> </ul>
Ripple & Noise	<ul style="list-style-type: none"> <li>• 50 mV pk-pk (DNR120)</li> <li>• 100 mV pk-pk (DNR240, DNR480)</li> <li>• 20 MHz bandwidth (may increase at low temperature extremes)</li> </ul>
Overvoltage Protection	<ul style="list-style-type: none"> <li>• Output clamps at 125-145% Vnom, auto recovery</li> </ul>
Overload Protection	<ul style="list-style-type: none"> <li>• 105-145% constant current, auto recovery</li> </ul>
Temp. Coefficient	<ul style="list-style-type: none"> <li>• <math>\pm 0.02\%/^{\circ}\text{C}</math></li> </ul>

## General

Efficiency	<ul style="list-style-type: none"> <li>• See table</li> </ul>
Isolation	<ul style="list-style-type: none"> <li>• 3000 VAC Input to Output</li> <li>• 1500 VAC Input to Ground</li> <li>• 500 VAC Output to Ground</li> </ul>
Switching Frequency	<ul style="list-style-type: none"> <li>• See table</li> </ul>
Signals	<ul style="list-style-type: none"> <li>• DC ON indicator Green LED, DC LOW indicator Red LED</li> <li>• DC OK: 24 V models</li> </ul>
MTBF	<ul style="list-style-type: none"> <li>• 450 kHrs typical Bellcore, Issue 6 at +40 °C, GB</li> </ul>

## Environmental

Operating Temperature	<ul style="list-style-type: none"> <li>• -10 °C to +70 °C, derate linearly from +60 °C at 2.5%/°C (DNR120)</li> <li>• -25 °C to +70 °C, derate linearly from +60 °C at 2.5%/°C (DNR240)</li> <li>• -25 °C to +70 °C, derate linearly from +55 °C at 2.5%/°C, (DNR240, DNR480) (see derating curves)</li> </ul>
Cooling	<ul style="list-style-type: none"> <li>• Convection-cooled with 25mm free space all sides</li> </ul>
Operating Humidity	<ul style="list-style-type: none"> <li>• 20-95% RH, non-condensing</li> </ul>
Storage Temperature	<ul style="list-style-type: none"> <li>• -25 °C to +85 °C</li> </ul>
Shock	<ul style="list-style-type: none"> <li>• 4 g, 22 ms, X, Y &amp; Z axis</li> </ul>
Vibration	<ul style="list-style-type: none"> <li>• 1 g, 10 Hz to 500 kHz, along X, Y &amp; Z axis</li> </ul>

## EMC &amp; Safety

Emissions	<ul style="list-style-type: none"> <li>• EN55022, class B conducted &amp; radiated</li> </ul>
Harmonic Currents	<ul style="list-style-type: none"> <li>• EN61000-3-2, class A</li> </ul>
Voltage Flicker	<ul style="list-style-type: none"> <li>• EN61000-3-3</li> </ul>
ESD Immunity	<ul style="list-style-type: none"> <li>• EN61000-4-2, level 3 Perf Criteria A</li> </ul>
Radiated Immunity	<ul style="list-style-type: none"> <li>• EN61000-4-3, level 3 Perf Criteria A</li> </ul>
EFT/Burst	<ul style="list-style-type: none"> <li>• EN61000-4-4, level 3 Perf Criteria A</li> </ul>
Surge	<ul style="list-style-type: none"> <li>• EN61000-4-5, level 3 Perf Criteria A</li> </ul>
Conducted Immunity	<ul style="list-style-type: none"> <li>• EN61000-4-6, level 3 Perf Criteria A</li> </ul>
Dips & Interruptions	<ul style="list-style-type: none"> <li>• EN61000-4-11, 30% 10 ms, 60% 100 ms, 100% 5000 ms Perf Criteria A, B, B</li> </ul>
Safety Approvals	<ul style="list-style-type: none"> <li>• EN60950-1, UL508, UL60950-1, cUL60950-1, Pollution Degree 2, CE Mark, UL60950-1, Overvoltage Category II, UL508, Overvoltage Category III</li> </ul>

**Models and Ratings**

Output Voltage	Output Voltage Trim	Output Current	Typical Efficiency	Typical Switching Frequency	Model Number
12 V	11.4-14.5 V	10.0 A	84%	80 kHz	DNR120AS12-I† <sup>(1,2)</sup>
24 V	22.5-30.0 V	5.0 A	86%	80 kHz	DNR120AS24-I† <sup>(1,2)</sup>
48 V	45.0-55.0 V	2.5 A	87%	80 kHz	DNR120AS48-I† <sup>(1,2)</sup>
24 V	22.5-28.5 V	10.0 A	89%	40 kHz	DNR240PS24-I† <sup>(1,2)</sup>
48 V	47.0-56.0 V	5.0 A	90%	40 kHz	DNR240PS48-I† <sup>(1,2)</sup>
24 V	22.5-28.5 V	20.0 A	89%	65 kHz	DNR480PS24-I† <sup>(1,2)</sup>
48 V	47.0-56.0 V	10.0 A	90%	65 kHz	DNR480PS48-I† <sup>(1,2)</sup>

**Notes**

1. Add suffix '-D' for detachable connector option.
2. For DC standby, remove '-I' and add '#' to the end of the model number.

† Available from Farnell. See pages 266-269.

^ Available from Newark. See pages 270-272.

**Derating Curves**

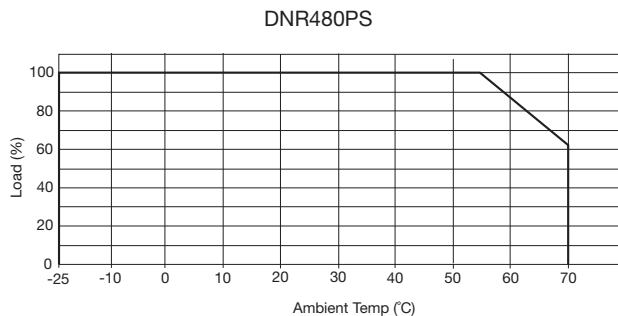
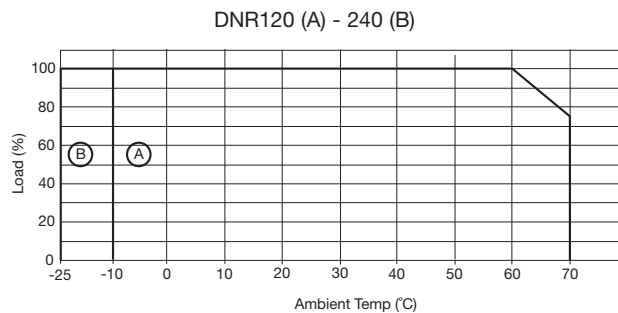

**DC OK**

Volt free contact closed when voltage at unit output is within specification. In standby system configured as shown this voltage may be provided by the PSU or battery.

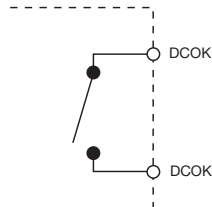

Open = Output fail  
Closed = Output good

Contact Rating: 0.3 A at 60 VDC  
500 VDC isolation

120 W Models

Optional detachable connector ('-D' Option)

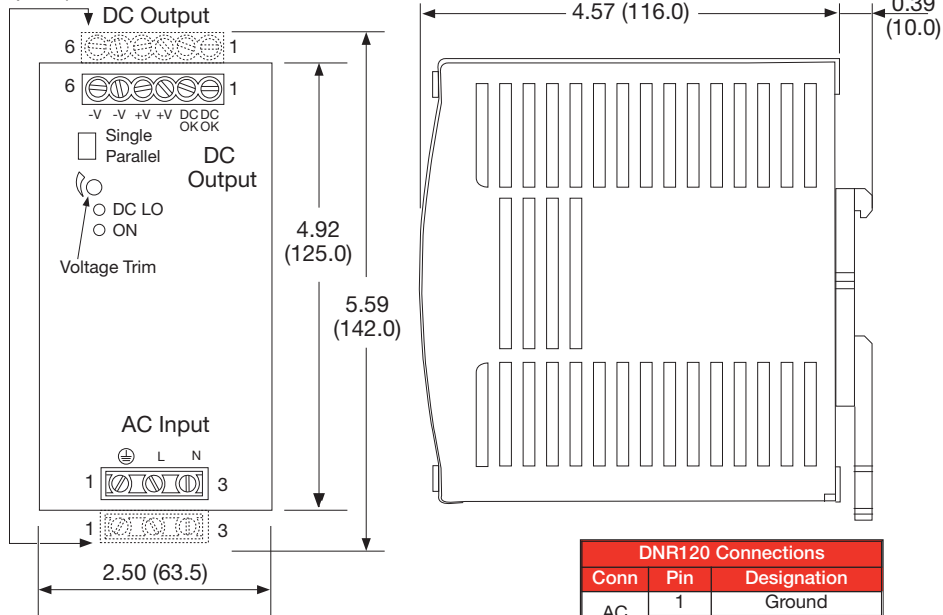

Notes

1. All dimensions in inches (mm).
2. Tolerance: ±0.02 (0.5) maximum.
3. Weight 1.4 lb (630 g) approx.
4. Screw terminal: 10-24 AWG cable size. Detachable connector version: 14-24AWG cable size.
5. Connection screw maximum torque: Input: 9 lbs-in (1.0 Nm), Output: 5.5 lbs-in (0.6 Nm)

DNR120 Connections		
Conn	Pin	Designation
AC Input	1	Ground
	2	Line
	3	Neutral
DC Output	1	DC OK *
	2	DC OK *
	3	Positive
	4	Positive
	5	Negative
	6	Negative

\* 24 V & standby models only.

240 W Models

Optional detachable connector ('-D' Option)

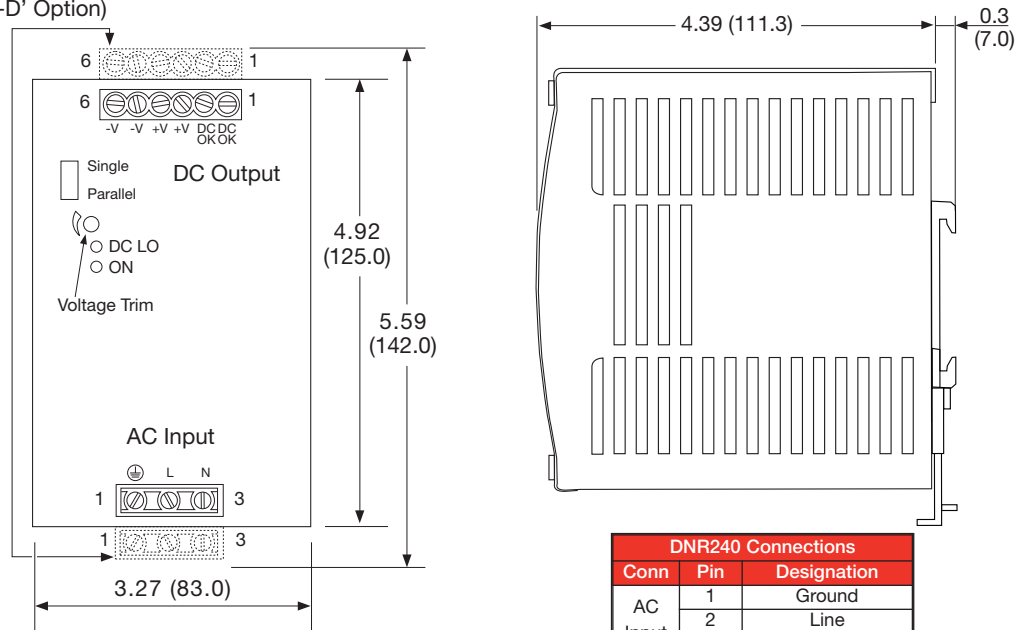

Notes

1. All dimensions in inches (mm).
2. Tolerance: ±0.02 (0.5) maximum.
3. Weight 3.0 lb (1360 g) approx.
4. Screw terminal: 10-24 AWG cable size. Detachable connector version: 14-24AWG cable size.
5. Connection screw maximum torque: Input: 9 lbs-in (1.0 Nm), Output: 5.5 lbs-in (0.6 Nm)

DNR240 Connections		
Conn	Pin	Designation
AC Input	1	Ground
	2	Line
	3	Neutral
DC Output	1	DC OK*
	2	DC OK*
	3	Positive
	4	Positive
	5	Negative
	6	Negative

\* 24 V & standby models only.

**Mechanical Details**

**480 W Models**

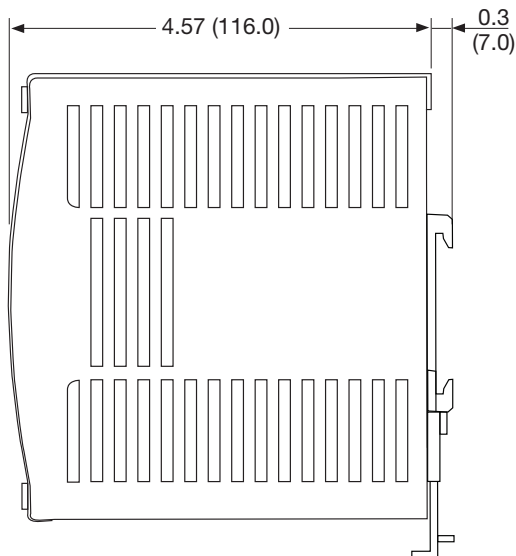
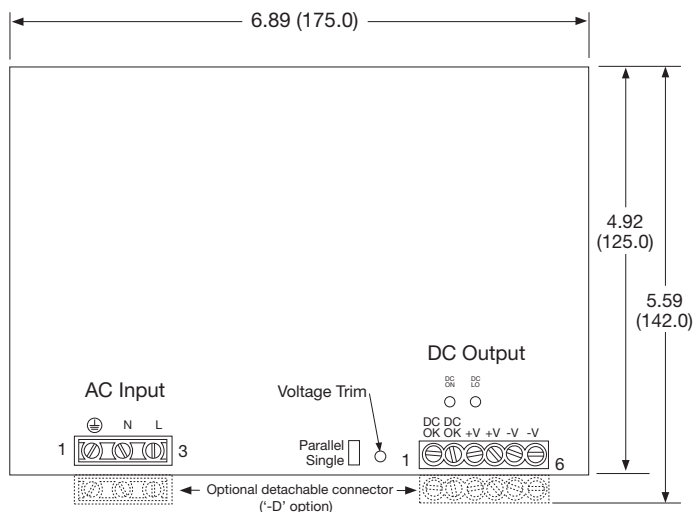

**Notes**

1. All dimensions in inches (mm).
2. Tolerance: ±0.02 (0.5) maximum.
3. Weight 4.2 lb (1920 g) approx.
4. Screw terminal: 10-24 AWG cable size. Detachable connector version: 14-24AWG cable size.
5. Connection screw maximum torque: Input: 9 lbs-in (1.0 Nm), Output: 5.5 lbs-in (0.6 Nm)

DNR480PS Connections		
Conn	Pin	Designation
AC Input	1	Ground
	2	Neutral
	3	Line
DC Output	1	DC OK*
	2	DC OK*
	3	Positive
	4	Positive
	5	Negative
	6	Negative

\* 24 V and standby models only.

**Standby Versions**

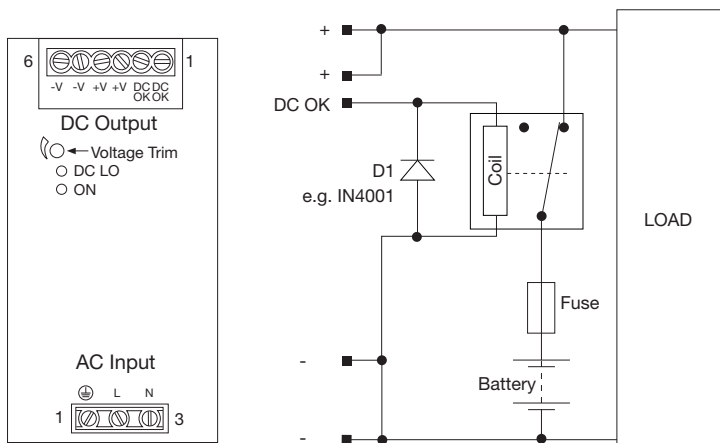

Output Set Voltages For Standby Versions			
Model <sup>(1)</sup>	Voltage	Current	DC OK Shutoff
DNR120AS12#	13.6 V	8.8 A	10.8 V ±5%
DNR120AS24#	27.2 V	4.4 A	21.6 V ±5%
DNR120AS48#	54.5 V	2.2 A	43.2 V ±5%
DNR240PS24#	27.2 V	8.8 A	21.6 V ±5%
DNR240PS48#	54.5 V	4.4 A	43.2 V ±5%
DNR480PS24#	27.2 V	17.6 A	21.6 V ±5%
DNR480PS48#	54.5 V	8.8 A	43.2 V ±5%

DNR120-480 Connections					
Conn	Pin	Designation	Conn	Pin	Designation
AC Input	1	Ground	DC Output	1	DC OK
	2	Line		2	DC OK
	3	Neutral		3	Positive
		4		Positive	
		5		Negative	
		6		Negative	

1. Suffix # indicates DC standby version.