

***THIS DOCUMENT IS FOR MAINTENANCE  
PURPOSES ONLY AND IS NOT  
RECOMMENDED FOR NEW DESIGNS***



# MV5089

## DTMF GENERATOR

The MV5089 is fabricated using ISO-CMOS high density technology and offers low power and wide voltage operation. An inexpensive 3.58MHz TV crystal completes the reference oscillator. From this frequency are derived 8 different sinusoidal frequencies which, when appropriately mixed, provide Dual-Tone Multi-Frequency (DTMF) tones.

Inputs are compatible with a standard 2-of-8 active-low keyboard and the keyboard entries determine the correct division of the reference frequency by the row and column counters.

D-to-A conversion, using R-2R ladder networks, results in a staircase approximation of a sinewave with low total distortion.

Frequency and amplitude stability over operating voltage and temperature range are maintained within industry specifications.

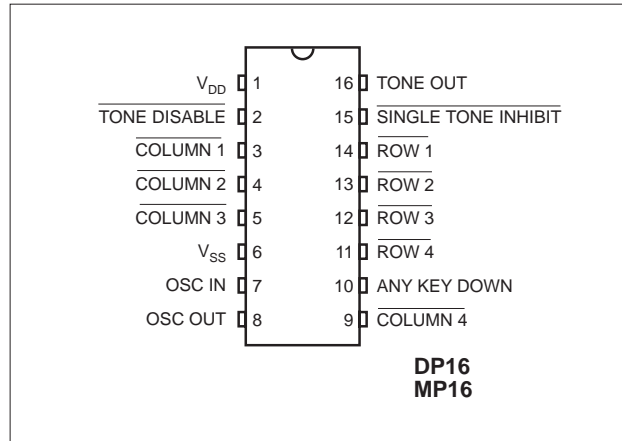

Figure 1: Pin connections - top view

### FEATURES

- Pin-for-Pin Replacement for MK5089
- Low Standby Power
- Minimum External Parts Count
- 2.75V to 10V Operation
- 2-of-8 Keyboard Input
- High Accuracy Tones Provided by 3.58MHz Crystal Oscillator
- Pin-Selectable Inhibit of Single Tone Generation

### APPLICATIONS

#### DTMF Signalling for

- Telephone Sets
- Mobile Radio
- Remote Control
- Point-of-Sale and Banking Terminals
- Process Control

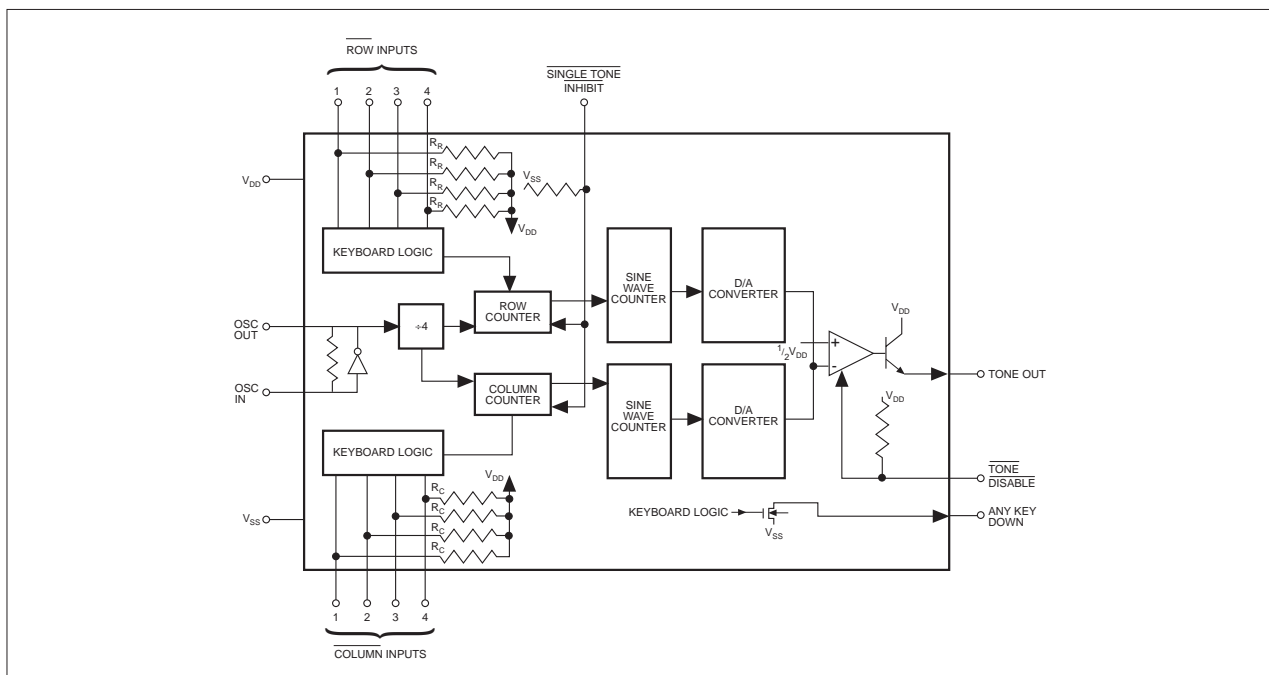

Figure 2: Functional block diagram

**OUTPUT FREQUENCY**

Table 1 shows the output frequency deviation from the standard DTMF frequencies when a 3.58MHz crystal is used as the reference.

The row and column output waveforms are digitally synthesised using R-2R D-to-A converters (see Fig.3), resulting in staircase approximations to a sinewave. An opamp mixes these tones to produce a dual-tone waveform. Single tone distortion is typically better than 7% and all distortion components of the mixed dual-tone should be 30dB relative to the strongest fundamental (column tone).

	Standard DTMF (Hz)	Tone Output Frequency Using 3.5795545 MHz Crystal	% Deviation from Standard	
Row	f <sub>1</sub> 697	701.3	+0.62	Low Group
	f <sub>2</sub> 770	771.4	+0.19	
	f <sub>3</sub> 852	857.2	+0.61	
	f <sub>4</sub> 941	935.1	-0.63	
Column	f <sub>5</sub> 1209	1215.9	+0.57	High Group
	f <sub>6</sub> 1336	1331.7	-0.32	
	f <sub>7</sub> 1477	1471.9	-0.35	
	f <sub>8</sub> 1633	1645.0	+0.73	

Table 1: Output frequency deviation

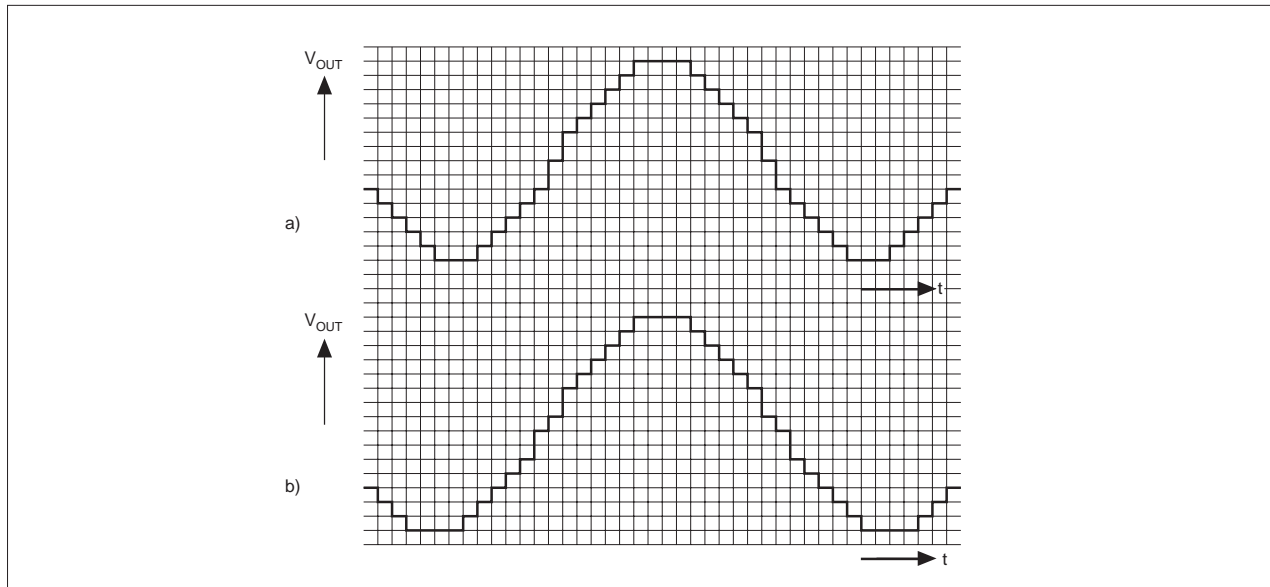

Figure 3: Typical sinewave output (a) Row tones (b) Column tones

**DISTORTION MEASUREMENTS**

THD for the single tone is defined by:

$$100 \left( \frac{\sqrt{V_{2f}^2 + V_{3f}^2 + V_{4f}^2 + \dots + V_{nf}^2}}{V_{\text{fundamental}}} \right) \%$$

Where V<sub>2f</sub> --- V<sub>nf</sub> are the Fourier components of the waveform.

THD for the dual tone is defined by:

$$100 \left( \frac{\sqrt{V_{2R}^2 + V_{3R}^2 + V_{nR}^2 + V_{2C}^2 + V_{3C}^2 + \dots + V_{nC}^2 + V_{\text{IMD}}^2}}{\sqrt{V_{\text{ROW}}^2 + V_{\text{COL}}^2}} \right)$$

- where V<sub>ROW</sub> is the row fundamental amplitude
- V<sub>COL</sub> is the column fundamental amplitude
- V<sub>2R</sub>—V<sub>nR</sub> are the Fourier component amplitudes of the row frequencies
- V<sub>2C</sub>—V<sub>nC</sub> are the Fourier component amplitudes of the column frequencies
- V<sub>IMD</sub> is the sum of all intermodulation components.

## PIN FUNCTIONS

PIN	NAME	DESCRIPTION
1	$V_{DD}$	Positive Power Supply
2	$\overline{\text{TONE DISABLE}}$	This input has an internal pull-up resistor to $V_{DD}$ . When connected to $V_{SS}$ no tones are generated by any key depression allowing the keyboard to be used for purposes other than DTMF signalling.
3,4,5,9	$\overline{\text{Column 1-4}}$	These CMOS inputs are held at $V_{SS}$ by an internal pull-up resistor and are activated by the application of $V_{SS}$ .
6	$V_{SS}$	Negative Power Supply (OV)
7,8	OSC In, OSC Out	On-chip inverter completes the oscillator when a 3,579545 MHz crystal is connected to these pins. OSC In is the inverter input and OSC Out is the output.
10	Any Key Down	This is an NMOS transistor output which switches to $V_{SS}$ while any key is depressed. Otherwise this output is high impedance. Switching is independent of Tone Disable and Single Tone Inhibit.
11,12,13,14	$\overline{\text{Row 1-4}}$	As $\overline{\text{Column 1-4}}$ inputs.
15	$\overline{\text{Single Tone Inhibit}}$	This input has a pull-up resistor to $V_{SS}$ . When left unconnected or tied to $V_{SS}$ , dual tones may be generated, but keyboard input combinations resulting in single tone generation are inhibited. When $V_{DD}$ is applied single or dual tones may be generated.
16	Tone Out	Emitter output of a bipolar NPN transistor whose collector is tied to $V_{DD}$ . Input to this transistor is from an op-amp which mixes the row and column tones.

## ROW AND COLUMN INPUTS

These inputs are compatible with the standard 2-of-8 keyboard or with an electronic input. Figures 4 and 5 show these input configurations and Fig.6 shows the internal chip structure of these inputs.

When operating with a keyboard, dual tones are generated when any single button is pushed.

With Single Tone Inhibit at  $V_{DD}$ , connection of  $V_{SS}$  to a single column causes the generation of that Column tone. Connection of  $V_{SS}$  to more than one Column will result in no Column tones being generated. Connection of  $V_{SS}$  to Rows only generates no tone - a Column must be connected to  $V_{SS}$ .

A single Row tone only may be generated by connecting 2 columns, and the desired row, to  $V_{SS}$ .

## OUTPUT TONE LEVEL

The output tone level of the MV5089 is proportional to the applied DC supply voltage.

A regulated supply will normally be used which may be designed to provide stability over the temperature range.

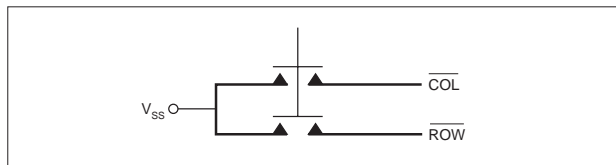

Figure 4: 2 of 8 DTMF keyboard

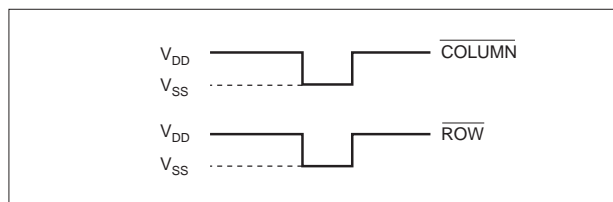

Figure 5: Electronic input

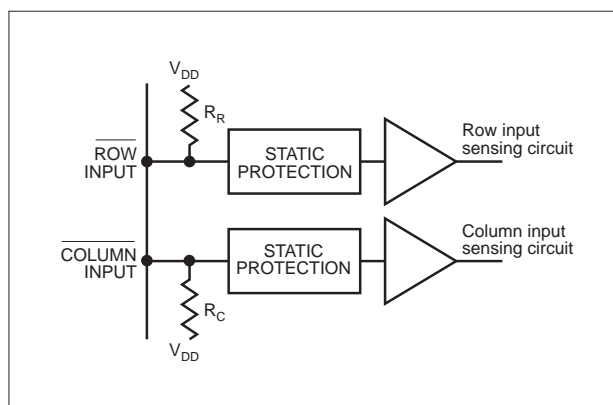

Figure 6: Row and Column inputs

# MV5089

## ABSOLUTE MAXIMUM RATINGS

	Min.	Max.		Min.	Max.
$V_{DD} - V_{SS}$ Voltage on any pin Current on any pin Operating temperature Storage temperature	-0.3V $V_{SS} - 0.3V$ -40°C -65°C	10.5V $V_{DD} + 0.3V$ 10 mA +85°C +150°C	Power dissipation Derate 16 mW/°C above 75°C (All leads soldered to PCB)		850 mW

## DC ELECTRICAL CHARACTERISTICS

Test conditions (unless otherwise stated):

$$T_{amb} = +25^{\circ}\text{C}, V_{DD} = 3V \text{ to } 10V$$

Characteristics		Symbol	Min.	Typ.	Max.	Units	
SUPPLY	Operating Supply Voltage	$V_{DD}$	2.75		10	V	Ref. to $V_{SS}$
	Standby Supply Current	$I_{DDs}$		0.2	100	uA	$V_{DD} = 3V$ No Key Depressed
				0.5	200	uA	$V_{DD} = 10V$ All outputs Unloaded
Operating Supply Current	$I_{DD}$		1.0	2.0	mA	$V_{DD} = 3V$ One Key Depressed	
			5.0	10.0	mA	$V_{DD} = 10V$ All outputs Unloaded	
INPUTS	SINGLE TONE	Input High Voltage	$V_{IH}$	$0.7V_{DD}$		$V_{DD}$	V
	INHIBIT	Input Low Voltage	$V_{IL}$	0		$0.3V_{DD}$	V
	TONE DISABLE	Input Resistance	$R_{IN}$		60		K $\Omega$
	ROW 1-4	Input High Voltage	$V_{IH}$	$0.7V_{DD}$		$V_{DD}$	V
COLUMN 1-4	Input Low Voltage	$V_{IL}$	0		$0.3V_{DD}$	V	
OUTPUTS	ANY KEY DOWN	Sink Current	$I_{OL}$	0.5			mA
		Leakage Current	$I_{OZ}$	1.0	1		uA
							$V_{DD} = 3V, V_{OL} = 0.5V$ $V_{DD} = 10V, V_{OL} = 0.5V$ $V_{DD} = 3V,$

## AC ELECTRICAL CHARACTERISTICS

Test conditions (unless otherwise stated):

$$T_{amb} = +25^{\circ}\text{C}, V_{DD} = 3V \text{ to } 10V$$

Characteristics		Symbol	Min.	Typ.	Max.	Units	
TONE OUT	OUTPUT LEVEL, ROW	$V_{OUT}$	-10	-8	-7	dBm	$V_{DD} = 3V$ . Single Tone. $R_L = 100k\Omega$
	PRE EMPHASIS, High Band		2.4	2.7	3.0	dB	
	OUTPUT DISTORTION (Dual Tone)				-20	dB	Total out-of-band power relative to sum of row and column fundamental power
	Tone Output Rise Time	$t_r$		3	5	ms	Time for waveform to reach 90% of magnitude of either frequency from initial key stroke

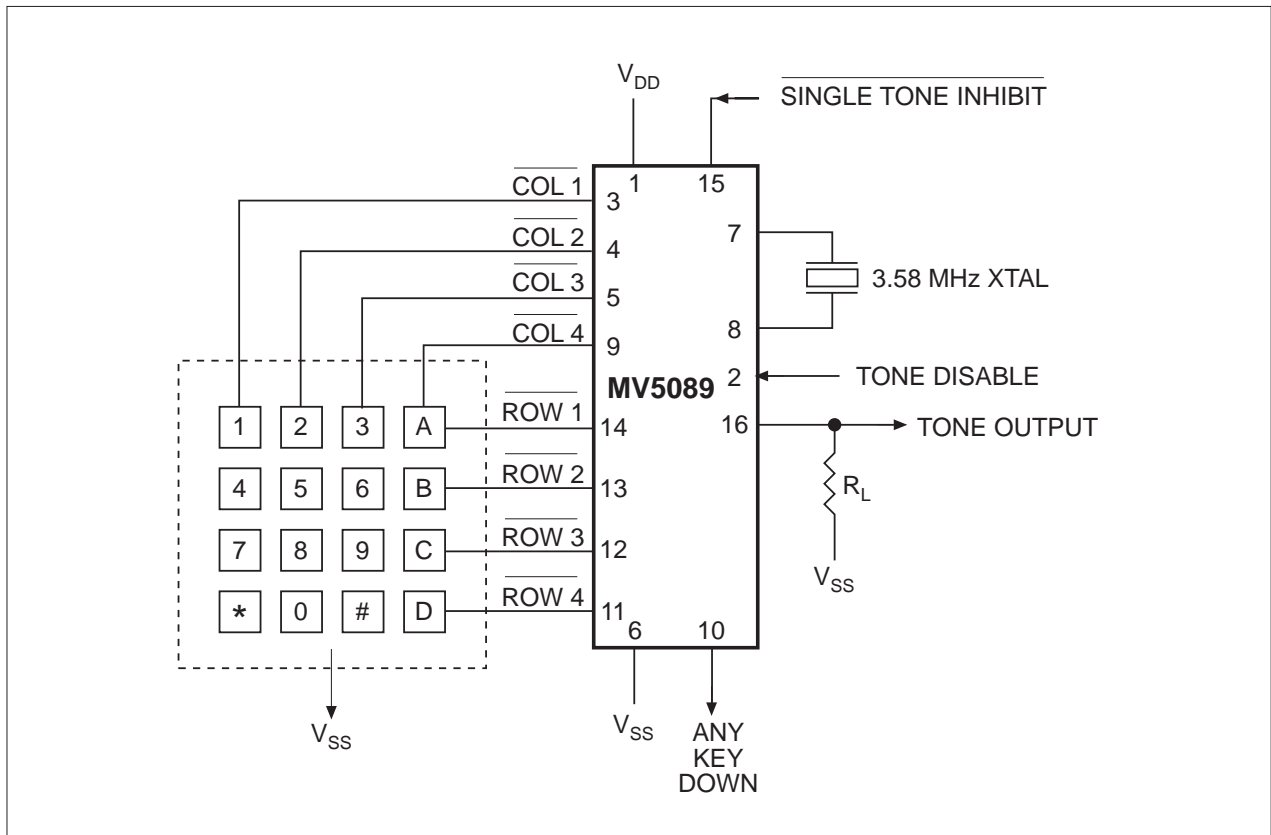

Figure 7: Connection diagram



**For more information about all Zarlink products  
visit our Web Site at  
[www.zarlink.com](http://www.zarlink.com)**

Information relating to products and services furnished herein by Zarlink Semiconductor Inc. trading as Zarlink Semiconductor or its subsidiaries (collectively "Zarlink") is believed to be reliable. However, Zarlink assumes no liability for errors that may appear in this publication, or for liability otherwise arising from the application or use of any such information, product or service or for any infringement of patents or other intellectual property rights owned by third parties which may result from such application or use. Neither the supply of such information or purchase of product or service conveys any license, either express or implied, under patents or other intellectual property rights owned by Zarlink or licensed from third parties by Zarlink, whatsoever. Purchasers of products are also hereby notified that the use of product in certain ways or in combination with Zarlink, or non-Zarlink furnished goods or services may infringe patents or other intellectual property rights owned by Zarlink.

This publication is issued to provide information only and (unless agreed by Zarlink in writing) may not be used, applied or reproduced for any purpose nor form part of any order or contract nor to be regarded as a representation relating to the products or services concerned. The products, their specifications, services and other information appearing in this publication are subject to change by Zarlink without notice. No warranty or guarantee express or implied is made regarding the capability, performance or suitability of any product or service. Information concerning possible methods of use is provided as a guide only and does not constitute any guarantee that such methods of use will be satisfactory in a specific piece of equipment. It is the user's responsibility to fully determine the performance and suitability of any equipment using such information and to ensure that any publication or data used is up to date and has not been superseded. Manufacturing does not necessarily include testing of all functions or parameters. These products are not suitable for use in any medical products whose failure to perform may result in significant injury or death to the user. All products and materials are sold and services provided subject to Zarlink's conditions of sale which are available on request.

Purchase of Zarlink's I<sup>2</sup>C components conveys a licence under the Philips I<sup>2</sup>C Patent rights to use these components in an I<sup>2</sup>C System, provided that the system conforms to the I<sup>2</sup>C Standard Specification as defined by Philips.

Zarlink and the Zarlink Semiconductor logo are trademarks of Zarlink Semiconductor Inc.

Copyright 2001, Zarlink Semiconductor Inc. All Rights Reserved.

**TECHNICAL DOCUMENTATION - NOT FOR RESALE**