



SCB TYPE SMD POWER INDUCTOR



FEATURE

- The rated current indicates the value of current when the inductance is 10% lower than its initial value at DC superposition or DC current when $\Delta t = 40^{\circ}\text{C}$, whichever is lower
- Tolerance of inductance
1.2 μH ~7.6 μH (100KHz) 10 μH ~1000 μH (1KHz)

APPLICATION

- DC/DC converter
- Power supplies for:
Portable communication equipment
- Camcorder
- LCD TV
- Notebook computer

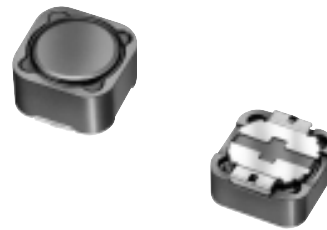

SHAPES & DIMENSION FOR SCB07XX SERIES

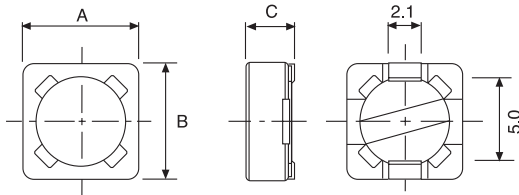

Dimension in m/m			
TYPE	A	B	C
SCB 0603	6.8±0.3	6.2±0.3	3.2 Max
SCB 0703	7.3±0.3	7.3±0.3	3.2±0.3
SCB 0704	7.3±0.3	7.3±0.3	4.6 Max

SHAPES & DIMENSION FOR SCB12XX SERIES

Dimension in m/m			
TYPE	A	B	C
SCB 1204	12±0.5	12±0.5	5.0 Max
SCB 1205	12±0.5	12±0.5	6.0 Max
SCB 1207	12±0.5	12±0.5	8.0 Max

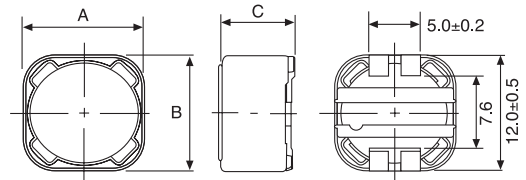

RECOMMENDED LAND PATTERNS FOR SMD

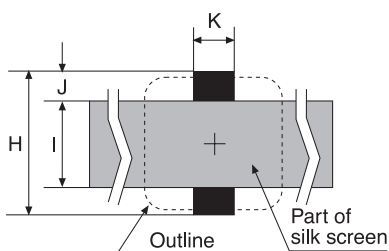

Dimension in m/m				
TYPE	H	I	J	K
SCB 0603	8.0	4.8	2.0	1.5
SCB 0703	8.0	4.8	2.0	2.8
SCB 0704	8.0	4.8	2.0	2.8
SCB 1204	12.8	7.0	2.9	5.4
SCB 1205	12.8	7.0	2.9	5.4
SCB 1207	12.8	7.0	2.9	5.4

SCB TYPE

SMD POWER INDUCTOR

STANDARD SPECIFICATION

Part No.	Inductance L (μH)	RDC (Ω) Max.						Rated C. Current (A) Max.					
		SCB 0603	SCB 0703	SCB 0704	SCB 1204	SCB 1205	SCB 1207	SCB 0603	SCB 0703	SCB 0704	SCB 1204	SCB 1205	SCB 1207
1R0	1.0	0.03						3					
1R2	1.2						0.007						9.80
1R5	1.5	0.032						2.2					
2R4	2.4			0.042			0.0115			3.5			8.00
2R9	2.9	0.068						1.94					
3R5	3.5						0.0135						7.50
4R0	4.0	0.080						1.63					
4R7	4.7		0.065	0.047	0.018	0.018	0.0158		2.27	2.47	5.2		6.80
5R5	5.5	0.096						1.40					
6R1	6.1						0.0176						6.60
7R6	7.6						0.0020						5.90
100	10	0.15	0.076	0.056	0.028	0.025	0.0216	1.10	1.68	1.84	4.50	4.00	5.40
120	12	0.20	0.098	0.06	0.038	0.027	0.0243	1.00	1.52	1.71	4.00	3.50	4.90
150	15	0.23	0.15	0.085	0.050	0.030	0.0270	0.90	1.33	1.47	3.20	3.30	4.50
180	18	0.27	0.17	0.10	0.057	0.030	0.0392	0.80	1.20	1.31	3.10	3.00	3.90
220	22	0.34	0.19	0.11	0.066	0.036	0.0432	0.74	1.07	1.23	2.90	2.80	3.60
270	27	0.38	0.23	0.18	0.080	0.051	0.0459	0.66	0.96	1.12	2.80	2.30	3.40
330	33	0.45	0.28	0.25	0.097	0.057	0.0648	0.59	0.91	0.96	2.70	2.10	3.00
390	39	0.49	0.34	0.26	0.132	0.068	0.0729	0.54	0.77	0.91	2.10	2.00	2.75
470	47	0.69	0.36	0.28	0.150	0.075	0.1	0.50	0.76	0.88	1.90	1.80	2.50
560	56	0.78	0.47	0.38	0.190	0.11	0.12	0.46	0.68	0.75	1.80	1.70	2.30
680	68	1.07	0.52	0.40	0.220	0.12	0.13	0.42	0.61	0.69	1.50	1.50	2.10
820	82	1.21	0.69	0.43	0.260	0.14	0.20	0.38	0.57	0.61	1.30	1.40	1.90
101	100	1.39	0.79	0.61	0.308	0.16	0.22	0.34	0.50	0.60	1.20	1.30	1.70
121	120	1.90	0.89	0.66	0.380	0.17	0.25	0.31	0.49	0.52	1.10	1.10	1.45
151	150	2.18	1.27	0.88	0.530	0.23	0.30	0.28	0.43	0.46	0.95	1.00	1.37
181	180	2.77	1.45	0.98	0.620	0.29	0.35	0.26	0.39	0.42	0.85	0.90	1.30
221	220	3.20	1.65	1.17	0.700	0.40	0.40	0.23	0.35	0.36	0.80	0.80	1.20
271	270	4.38	2.31	1.64	0.870	0.46		0.22	0.32	0.34	0.60	0.75	
331	330	4.94	2.62	1.86	0.990	0.51	0.55	0.19	0.28	0.32	0.50	0.68	1.00
391	390		2.94	2.85		0.69	0.58		0.26	0.29		0.65	0.80
471	470	5.00	4.18	3.01		0.77		0.16	0.24	0.26		0.58	
561	560	5.23	4.67	3.62		0.86		0.15	0.22	0.23		0.54	
681	680		5.73	4.63		1.20			0.19	0.22		0.48	
821	820		6.54	5.20		1.34			0.18	0.20		0.43	
102	1000		9.44	6.00		1.53			0.16	0.18		0.40	

1. Test Freq. (L)

1.2~7.6μH (100KHz / IV) 10~1000μH (1KHz / IV)

2. Tolerance of Inductance

SCB 0603	1.0~7.6μH +40/-20%(N)	10~560μH ± 20%(M)
SCB 0703	1.0~7.6μH +40/-20%(N)	10~1000μH ± 20%(M)
SCB 0704	1.0~7.6μH +40/-20%(N)	10~1000μH ± 20%(M)
SCB 1204	1.0~7.6μH +40/-20%(N)	10~330μH ± 20%(M)
SCB 1205	1.0~7.6μH +40/-20%(N)	10~1000μH ± 20%(M)
SCB 1207	1.0~7.6μH +40/-20%(N)	10~1000μH ± 20%(M)

SCB0603, SCB1204, SCB1205, SCB1207

* This indicates the value of current when the inductances is 10% lower than its initial value at D.C. superposition or D.C. current when at Δt=40°C whichever is lower. (Ta=25°C)

SCB0703, SCB0704

* This indicates the value of current when the inductances is 75% more than its nominal value and temperature rising Δt=40°C lower at D.C. superposition.

TYPICAL ELECTRICAL CHARACTERISTICS CURVE
SCB0603, 0703, 0704, 1024, 1205, 1207
TEST INSTRUMENT: HP 4263B Zentech 301A
INDUCTANCE-CURRENT (REFERENCE)

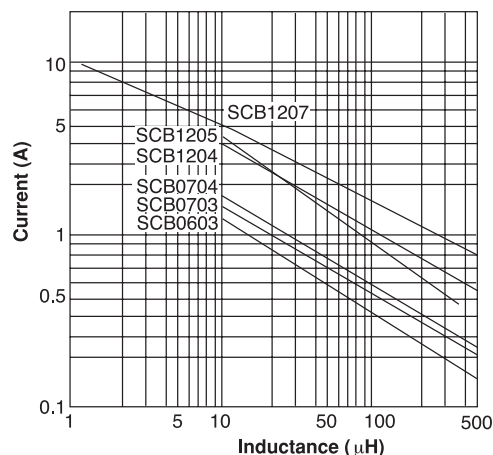

SCB TYPE SMD POWER INDUCTOR

PACKAGING FOR SMC

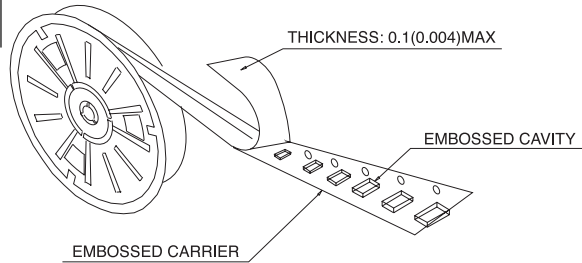

CARRIER TAPE REELS

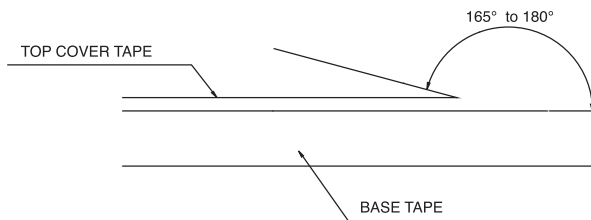
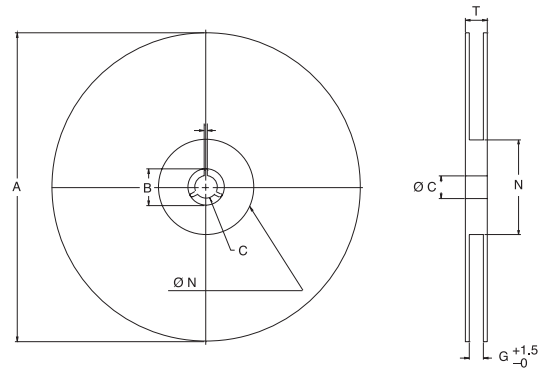

The force for tearing off cover tape is 10 to 60 grams in the arrow direction.

MATERIAL: PAPER/PLASTIC

Dimension in mm

TYPE	A	B	C	G	N	T	MATERIAL
8mm	178	21.0±0.8	13.0±0.2	8.4	55	12.4	PAPER
12mm	178	21.0±0.8	13.0±0.2	12.4	55	16.4	PAPER
16mm	178	21.0±0.8	13.0±0.2	16.4	55	20.4	PAPER
24mm	178	21.0±0.8	13.0±0.2	24.4	100	28.4	PAPER
12mm	330	21.0±0.8	13.0±0.2	12.4	100	16.4	PLASTIC
16mm	330	21.0±0.8	13.0±0.2	16.4	100	20.4	PLASTIC
24mm	330	21.0±0.8	13.0±0.2	24.4	100	28.4	PLASTIC
24mm	330	21.0±0.8	13.0±0.2	24.4	75	28.4	PAPER
32mm	330	21.0±0.8	13.0±0.2	32.4	75	36.4	PAPER

TAPE DIMENSION/PACKAGING

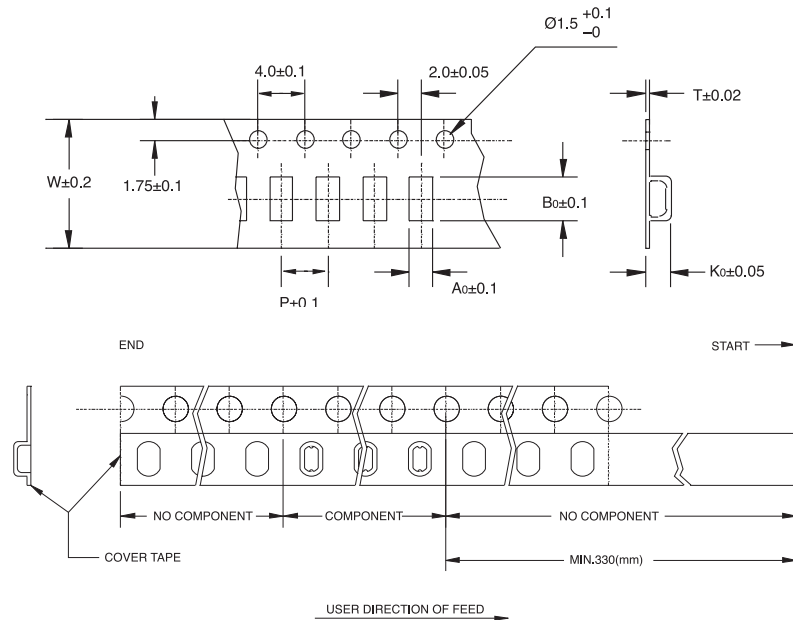

TYPE	A0	B0	K0	W	P	T	CHIPS/REEL	Dimension in mm
SCB 0603	6.20	6.80	3.80	16.0	12.0	0.40	1000	
SCB 0703	7.60	7.60	3.70	16.0	12.0	0.30	500	
SCB 0704	7.60	7.60	5.40	16.0	12.0	0.40	500	
SCB 1204	12.60	12.60	5.20	24.0	16.0	0.40	500	
SCB 1205	12.60	12.60	5.80	24.0	16.0	0.40	500	
SCB 1207	12.60	12.60	8.00	24.0	16.0	0.40	500	
SFB 1205	12.60	12.60	5.80	24.0	16.0	0.40	500	
SFB 1207	12.60	12.60	8.00	24.0	16.0	0.40	500	