

## Plasma Panel Display Module

256 x 64 Graphics Display with Drive Electronics,  
+ 5V CMOS Level Video Interface and Integrated DC Converter



The APD-256G064A has been designed to offer high brightness and superior viewing aesthetics in a package that is very affordable. This display is ideal for low to medium level information content messages and would be ideal for applications such as arcade games, process control, POS terminals, medical equipment, message centers and ATM machines.

The APD-256G064A DC Plasma display offers viewing qualities designers seek such as high contrast, viewing angle of 150° minimum, and long distance readability. It is bright (40 foot lamberts minimum) with characters and graphics figures presented in a pleasing neon orange color against a black background. Plasma is much more readable and eye-pleasing than liquid crystal or vacuum fluorescent displays and is filterable to red, amber, or neutral density.

These plasma display panels are driven in a standard row - column refresh method much like a CRT display. The designer need only supply + 5V CMOS level signals for SERIAL DATA, DOT CLOCK, COLUMN LATCH, ROW DATA, ROW CLOCK and DISPLAY ENABLE. The SERIAL DATA is entered with the DOT CLOCK up to frequencies as high as 8mHz. After a row of 256 pixels is clocked in, the COLUMN LATCH signal is toggled and the data is latched. At the time the data is latched, the display is briefly disabled using the DISPLAY ENABLE signal, then the row pointer is advanced with the ROW CLOCK signal. Once each frame the ROW DATA must be asserted to synchronize the column serial data with the beginning row. The recommended scanning frequency is approximately 70Hz but may be as high as 200Hz. The high clock rate on the data clock allows for rapid refresh and maximum access time to the refresh ram.

### FEATURES

- + 5V CMOS level video interface (with 4.7k pull-up resistors)
- On board DC converter
- Slim Profile
- Large, bright characters and graphics
- Highly visible for long distance viewing

### ELECTRICAL SPECIFICATIONS

**Voltages Required:** VDC: + 12 to + 24VDC  
V<sub>cc</sub>: + 5VDC

**Power Required:** Typical = 20 watts, Maximum = 65 watts

### OPTICAL SPECIFICATIONS

**Viewing Area:** 15.85" W x 5.00" H

**Pixel Pitch:** 0.062"

**Pixel Size:** 0.038" diameter

**Color:** Neon orange

**Text with typical 5x7 character matrix using 1 column between characters and 1 row between lines.**

**Maximum Number of Characters per Line:** 42

**Maximum Number of Lines:** 16

**Luminance:** 40 foot lamberts minimum

### ENVIRONMENTAL SPECIFICATIONS

**Operating Temperature:** 0°C to + 70°C

**Storage Temperature:** - 20°C to + 85°C

**Relative Operating Humidity:** To 95% non-condensing

**Mechanical Shock:** 30G

**Vibration:** 3G

**Operating Altitude:** 10,000 feet

STANDARD ELECTRICAL SPECIFICATIONS*					
DESCRIPTION	SYMBOL	MIN.	TYP.	MAX.	UNITS
Logic supply	V <sub>cc</sub>	+ 4.5	+ 5.0	+ 5.5	VDC
Logic current	I <sub>cc</sub>	—	+ 50.0	+ 200	mADC
DC converter input	VDC	+ 10	+ 24.0	+ 28.0	VDC
DC converter power @ + 12V	IDC	Screen Clear 0.13	50% Lit 2.7	100% Lit 5.5	ADC
Logic 1 Input	V <sub>ih</sub>	2/3V <sub>cc</sub>	—	—	VDC
Logic 0 Input	V <sub>il</sub>	—	—	1/3V <sub>cc</sub>	VDC

\*Recommended operating voltages. All maximums are absolute maximum.

## DIMENSIONS in inches [millimeters]

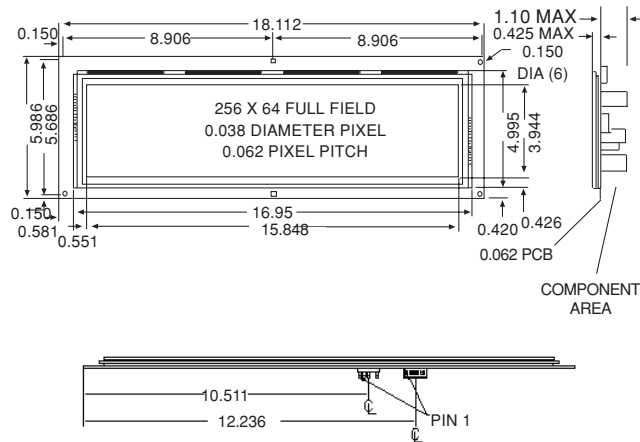

### PIN DESCRIPTION

#### P3, POWER CONNECTOR

AMP #640445-5 or equivalent. (Mates with AMP 640428-5, MOLEX 09-05-3051 or equivalent.)

PIN	SIGNAL	DESCRIPTION
1	GND	GROUND
2	VDC	DC Converter Supply
3	V <sub>CC</sub>	Logic Supply
4	KEY	Used to key connector
5	GND	GROUND

#### P2, DATA CONNECTOR

AMP #103309-2 or equivalent. (Mates with AMP 746195-2, MOLEX 39-27-1146 or equivalent.)

PIN	DESCRIPTION	PIN	DESCRIPTION
1	DISPLAY ENABLE	2	GROUND
3	ROW DATA	4	GROUND
5	ROW CLOCK	6	GROUND
7	COLUMN LATCH	8	GROUND
9	DOT CLOCK	10	GROUND
11	SERIAL DATA	12	GROUND
13	No connect	14	GROUND

**DESCRIPTION OF INPUT SIGNALS**

**DOT CLOCK** - This signal enters the SERIAL DATA on each low to high transition. A total of 256 DOT CLOCK transitions must be present for each line of column/anode data.

**SERIAL DATA** - This signal presents the pixel data in positive logic format. A logic one represents a lit pixel and a logic zero represents an extinguished pixel. Data is entered from right to left. The first pixel data entered will represent the leftmost pixel in the row.

**COLUMN LATCH** - This signal latches the pixel data into the driver outputs. When the COLUMN LATCH signal goes to logic one the data entered previously will fall through to the driver outputs. When the signal returns to a logic zero, the data is latched and the shift register is now ready to accept the next row of data. Must be held low while entering new SERIAL DATA.

**DISPLAY ENABLE** - This signal enables the output drivers. Using a duty cycle control, this signal may also be used for intensity control. The DISPLAY ENABLE must be at logic zero before the COLUMN LATCH signal transitions. To avoid display blurring, the ROW CLOCK signal should also transition while DISPLAY ENABLE is a logic zero. It is recommended that this signal remain low for 10 $\mu$ S min.

**ROW DATA** - This signal is the first line marker for the scan. This input should be held high to correspond to the first row of pixel data.

**ROW CLOCK** - This signal clocks ROW DATA on the falling edge. The ROW CLOCK signal is repetitive and must be present for proper scanning of the display module.

The APD-256G064A has a unique input protection circuit that assures the column drivers stay blanked on power up. The protection circuit unblanks the column drivers when the ROW CLOCK signal begins (i.e. the display begins scanning).

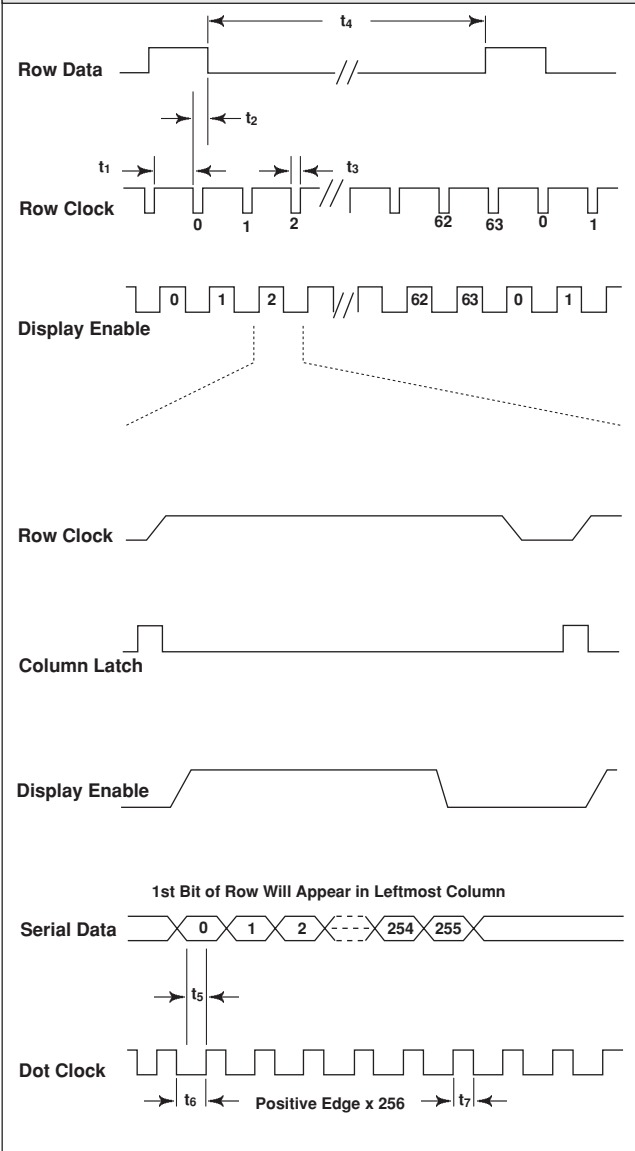
**LOGIC AND DATA TIMING**

PARAMETER	MINIMUM	TYPICAL	MAXIMUM	UNITS
$t_1$	100	—	—	nS
$t_2$	5	—	—	$\mu$ S
$t_3$	1	—	—	$\mu$ S
$t_4$	—	70	200	Hz
$t_5$	25	—	—	nS
$t_6$	75	—	—	nS
$t_7$	75	—	—	nS

**ORDERING INFORMATION**

Plasma Display Module with Drivers, CMOS Video Interface, and DC/DC Converter.....	APD-256G064A
Data Connector Kit.....	280105-05
Power Connector Kit.....	280108-13
Video Controller (+5V) Parallel and Serial Interface.....	PDS-500
Video Controller (+12V) Parallel and Serial Interface.....	PDS-500-1



## Notice

Specifications of the products displayed herein are subject to change without notice. Vishay Intertechnology, Inc., or anyone on its behalf, assumes no responsibility or liability for any errors or inaccuracies.

Information contained herein is intended to provide a product description only. No license, express or implied, by estoppel or otherwise, to any intellectual property rights is granted by this document. Except as provided in Vishay's terms and conditions of sale for such products, Vishay assumes no liability whatsoever, and disclaims any express or implied warranty, relating to sale and/or use of Vishay products including liability or warranties relating to fitness for a particular purpose, merchantability, or infringement of any patent, copyright, or other intellectual property right.

The products shown herein are not designed for use in medical, life-saving, or life-sustaining applications. Customers using or selling these products for use in such applications do so at their own risk and agree to fully indemnify Vishay for any damages resulting from such improper use or sale.