

Plasma Panel Display Modules

192 x 96 Graphics Display with Drive Electronics Controller and Serial Interface

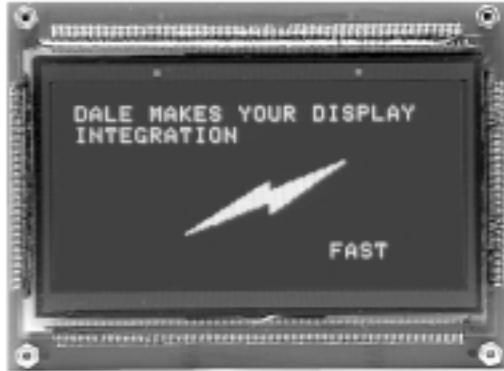

FEATURES

- 192 x 96 full field dot matrix
- Text or graphics modes
(8 rows of 32 characters in text mode)
- Only + 5 VDC required
- Very compact size
- Wide Viewing angle (150°)
- Flicker free refresh
- Editing functions
- High brightness

The APD-192G096 consists of a graphics DC plasma display panel, controller and DC/DC converter.

The controller maintains all the refresh memory, character generation and control logic to enable the module to serve as a direct readout device for many applications including POS terminals, industrial controls and microprocessor instruments. Single byte, two and three byte commands allow simplified code generation, yet accomplish complex display tasking such as scrolling or inserting lines and characters. An EPROM based character generator is easily configured for any character set, but comes standard with three variations of international fonts (Standard International, International plus Kata-kana and International plus Russian) and 128 block graphics characters. Alternate character sets can be factory or user programmed. The pixel pattern in text mode is 5 x 7 pixels in an 6 x 12 block. Two means of using graphics are supported. The first is character graphics, in which the user sends the proper ASCII code to select the desired graphics character. The character graphics mode allows easy mixing of text and graphics images. The second is the bit plot mode (using set and reset commands) which allows any graphic pattern to be drawn a bit at a time. Character entry in bit mode allows for 5 x 7 ASCII characters to be placed at any given pixel location within the pixel map. A FIFO buffer is used to capture incoming data in the event the display's microprocessor is busy with a length command. Handshaking is suggested when operating in the graphics mode. The data format is 1 start bit, 8 data bits and 1 stop bit.

OPTICAL SPECIFICATIONS

Viewing Area: 4.966" [126.14mm] W x 2.470" [62.74mm] H.

Pixel Size: 0.017" [0.43mm] square.

Pixel Pitch: 0.026" [0.66mm].

Luminance: 70 foot lamberts.

STANDARD ELECTRICAL SPECIFICATIONS				
	MIN.	TYP.	MAX.	UNITS
Supply Voltage	4.75	5.0	5.25	V
Supply Current	—	1.0	2.5	A

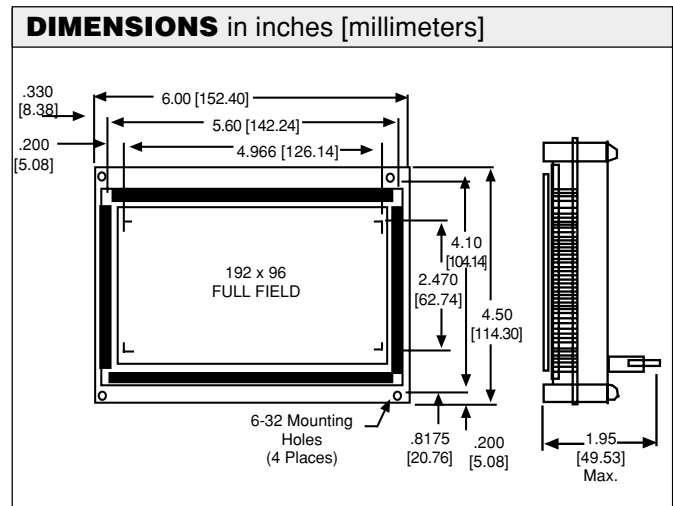

ORDERING INFORMATION

DESCRIPTION	PART NUMBER
Display, Drive Electronics and Controller	APD-192G096
Mating Connector	280105-02
Non-Glare Filter (amber circular polarized) - other filters available, contact factory	280109-16



Notice

Specifications of the products displayed herein are subject to change without notice. Vishay Intertechnology, Inc., or anyone on its behalf, assumes no responsibility or liability for any errors or inaccuracies.

Information contained herein is intended to provide a product description only. No license, express or implied, by estoppel or otherwise, to any intellectual property rights is granted by this document. Except as provided in Vishay's terms and conditions of sale for such products, Vishay assumes no liability whatsoever, and disclaims any express or implied warranty, relating to sale and/or use of Vishay products including liability or warranties relating to fitness for a particular purpose, merchantability, or infringement of any patent, copyright, or other intellectual property right.

The products shown herein are not designed for use in medical, life-saving, or life-sustaining applications. Customers using or selling these products for use in such applications do so at their own risk and agree to fully indemnify Vishay for any damages resulting from such improper use or sale.