

PART NUMBER: VSUP-1K5 series

DESCRIPTION: switching power supply

features

- current sharing capability at parallel operation
- 0.98 typical power factor
- programmable output voltage
- universal AC input
- short circuit, overload, over voltage, over temperature protected
- forced air cooling by built-in DC fan
- power failure signal
- built-in remote sense
- built-in remote inhibit
- 2 year warranty



model	output ¹	output current		max.power	ripple & noise ²		efficiency
		minimum	maximum		regulation	(Vpp)	
VSUP-1K5-12	12 V	0 A	125 A	1500 W	<1%	1%	84%
VSUP-1K5-15	15 V	0 A	100 A	1500 W	<1%	1%	85%
VSUP-1K5-18	18 V	0 A	83.3 A	1500 W	<1%	1%	85%
VSUP-1K5-24	24 V	0 A	62.5 A	1500 W	<1%	1%	88%
VSUP-1K5-30	30 V	0 A	50 A	1500 W	<1%	1%	88%
VSUP-1K5-36	36 V	0 A	41.6 A	1500 W	<1%	1%	88%
VSUP-1K5-48	48 V	0 A	31.2 A	1500 W	<1%	1%	89%
VSUP-1K5-60	60 V	0 A	25 A	1500 W	<1%	1%	90%

notes:

1 output voltage is measured at output power connector.

2 ripple and noise is measured from 10 KHz to 20 MHz at output terminals with 0.1 μ F ceramic capacitor and a 22 μ F electrolytic capacitor in parallel.

INPUT

parameter	conditions/description	min	nom	max	units
input frequency		47		63	Hz
input voltage	12, 15, 18V	180		264	VAC
	24, 30, 36, 48, 60V	110		264	VAC
inrush current	peak measured at 230 VAC at full load, cold start			120	A

PART NUMBER: VSUP-1K5 series

DESCRIPTION: switching power supply

OUTPUT

parameter	conditions/description	min	nom	max	units
hold-up time	full load at 230 VAC			12	mS
programming	output voltage programmable through external 0~5V control voltage on VCI.	20		100	%
voltage adjustability	typical adjustment by potentiometer 20%-100% adjustment by 1-5Vdc external control	-5		+5	%
temp. coefficient			±0.04		%/°C

PROTECTION CIRCUIT

parameter	conditions/description	min	nom	max	units
overload	shutdown				
overvoltage		110		135	%

GENERAL AND SAFETY

parameter	conditions/description	min	nom	max	units
operating temp.		0		50	°C
operating humid.		20%		90%	RH
storage temp.		-20		85	°C
storage humid.		10		95%	RH
vibration	period of 60 min. for each axis	10		200	Hz
EMC	EN55022, EN61000-4-2,3,4,5,6,8,11, EN61000-3-2-3 ENV50204				
safety regulation	approved to UL/cUL 1950, TUV EN60950				
leakage current	at 240 VAC			<7.0	mA
cooling	Power rating and temperature controlled fan				

MECHANICAL

parameter	conditions/description	min	nom	max	units
weight			3.8		Kg
enclosure	279(L) x 203(W) x 63.5(H)				mm

LOGIC CONNECTOR

parameter	conditions/description
pin assignments: connector 1	suggested mating connector: JST XHP-6 or equivalent 1. VCI - command input voltage for output programming 2. REF - 5V reference output. can be used to derive VCI 3. PG - power good signal 4. GND - return / output ground 5. INH - remote on-off / remote Inhibit 6. PAR - current sharing / parallel function

REMOTE SENSE

parameter	conditions/description
pin assignments: connector 2	suggested mating connector: JST XHP2 or equivalent 1. VS(-) - remote sense (-) 2. VS(+) - remote sense (+)

PART NUMBER: VSUP-1K5 series

DESCRIPTION: switching power supply

LOGIC CONNECTIONS

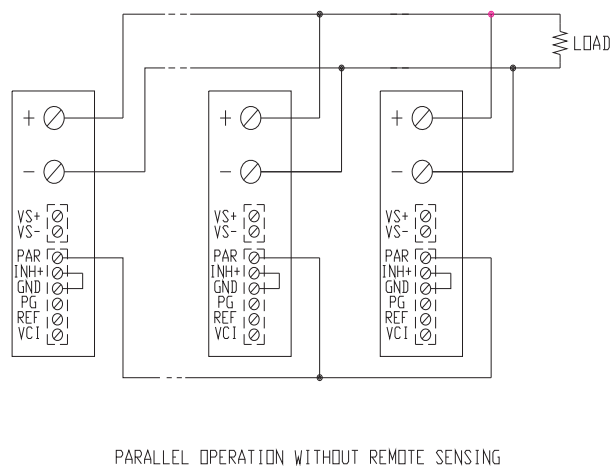
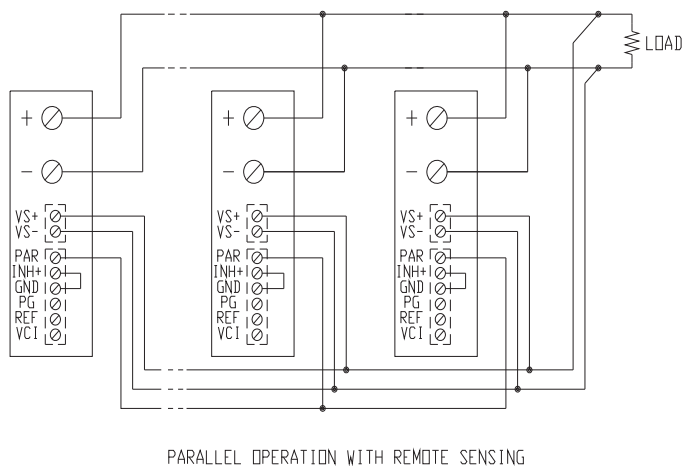
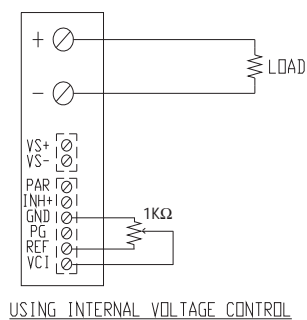
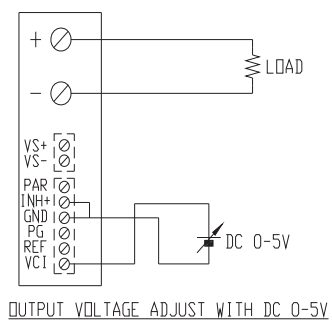
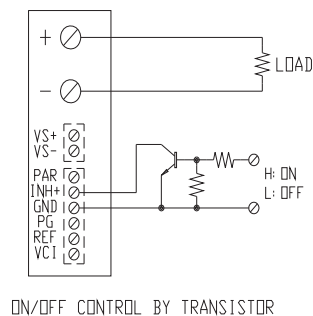
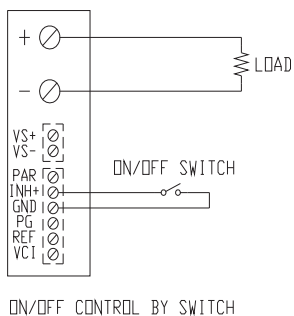
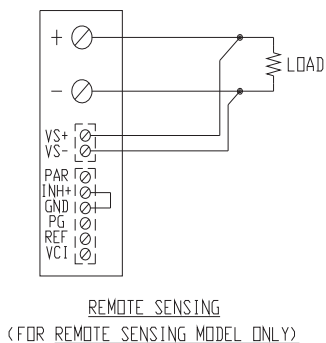

PART NUMBER: VSUP-1K5 series

DESCRIPTION: switching power supply

MECHANICAL DRAWING

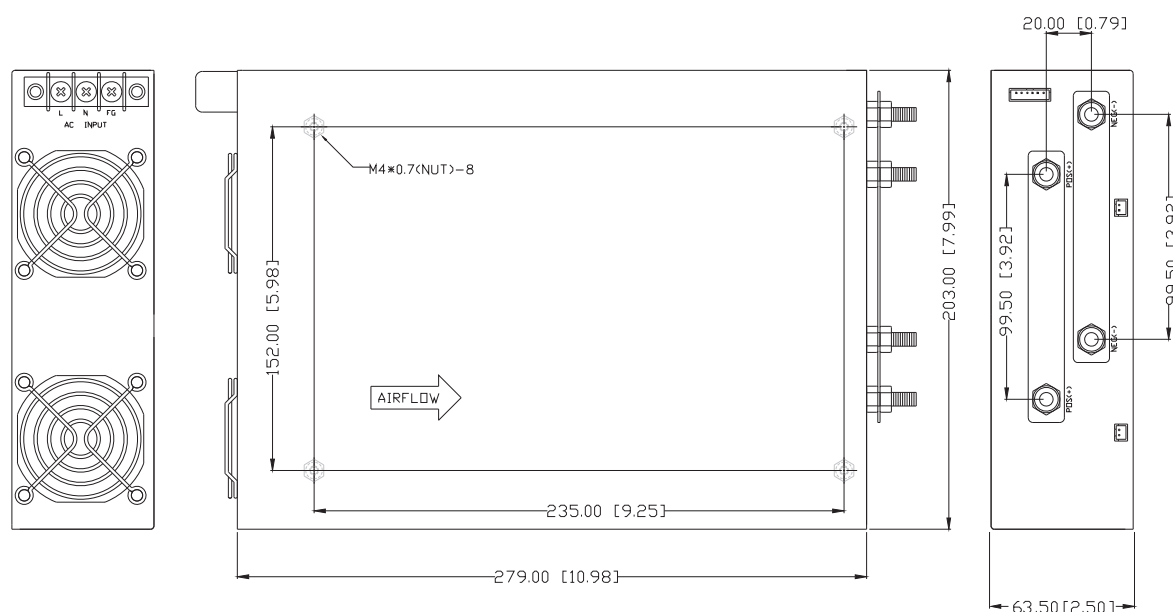

DERATING CURVES

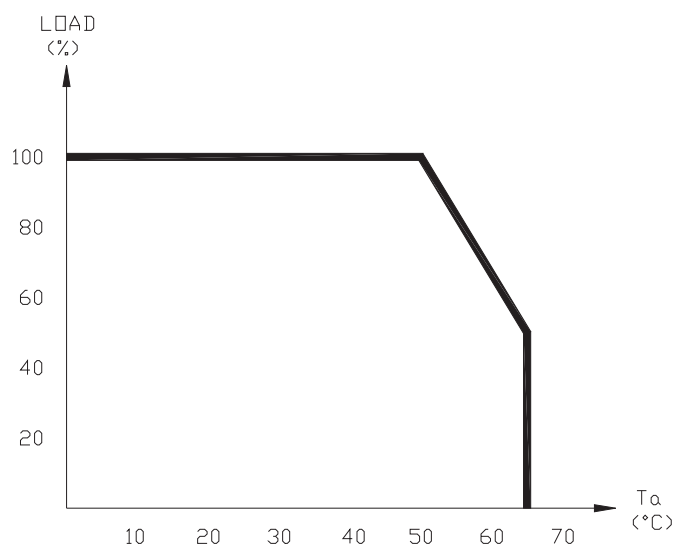

load derating curve

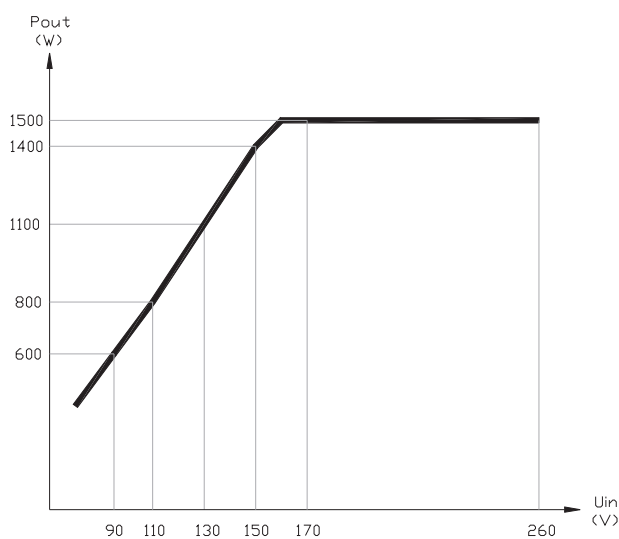

output power vs. input voltage derating curve