

CRYSTAL CONTROLLED OSCILLATORS

SURFACE MOUNT 3.3V HCMOS VCXO



VSLD52C1

ABSOLUTE MAXIMUM RATINGS

TABLE 1.0

PARAMETER	UNITS	MINIMUM	NOMINAL	MAXIMUM	UNITS	NOTE
Storage Temperature		-40	-	85	°C	
Supply Voltage	(Vcc)	-0.5	-	7.0	Vdc	
Control Voltage	(Vc)	-0.5	-	7.0	Vdc	

OPERATING SPECIFICATIONS

TABLE 2.0

PARAMETER		MINIMUM	NOMINAL	MAXIMUM	UNITS	NOTE
Center Frequency	(Fo)	2	-	156.25	MHz	
Frequency Stability (Vc=1.65V)		-45	-	45	ppm	
Aging (15 years)		-5	-	5		
Total Frequency Tolerance		-50	-	50	ppm	1
Operating Temperature Range		0	-	70	°C	
Supply Voltage	(Vcc)	3.135	3.300	3.465	Vdc	
Supply Current	(Icc)	-	-	50	mA	
Jitter (BW=10Hz to 20MHz)		-	-	5	pS rms	
Jitter (BW=12kHz to 20MHz)		-	-	1	pS rms	
SSB Phase Noise at 10Hz offset		-	-65	-	dBc/Hz	
SSB Phase Noise at 100Hz offset		-	-95	-	dBc/Hz	
SSB Phase Noise at 1KHz offset		-	-130	-	dBc/Hz	
SSB Phase Noise at 10KHz offset		-	-135	-	dBc/Hz	
SSB Phase Noise at 100KHz offset		-	-140	-	dBc/Hz	

INPUT CHARACTERISTICS

TABLE 3.0

PARAMETER		MINIMUM	NOMINAL	MAXIMUM	UNITS	NOTE
Control Voltage Range	(Vc)	0.3	1.65	3.0	Vdc	
Frequency Pullability		±100	-	-	ppm	2
Absolute Pull Range		±50	-	-	ppm	3
Monotonic Linearity		-10	-	10	%	
Input Impedance		-	50K	-	Ohm	
Modulation Bandwidth (3dB)		15	-	-	KHz	

HCMOS OUTPUT CHARACTERISTICS

TABLE 4.0

PARAMETER		MINIMUM	NOMINAL	MAXIMUM	UNITS	NOTE
LOAD		-	-	15	pF	
Voltage (High)	(Voh)	2.4	-	-	Vdc	
(Low)	(Vol)	-	-	0.4	Vdc	
Current (High)	(Ioh)	-8	-	-	mA	
(Low)	(Iol)	-	-	8	mA	
Duty Cycle measured at 1.5 Vdc		40	50	60	%	
Rise / Fall Time 10% to 90%		-	-	5	nS	

PACKAGE CHARACTERISTICS

TABLE 5.0

Package	Non-hermetic package consisting of an FR4 subtrate with grounded metal cover.
---------	---

PROCESS RECOMMENDATIONS

TABLE 6.0

Solder Reflow	The component solder used internal to this device has a melting point of 221°C. The peak temperature inside the device should be less than or equal to 220°C for a maximum of 10 seconds
Wash	Ultrasonic cleaning is not recommended.

Notes

- Inclusive of calibration, frequency vs. temperature stability, supply voltage change, load change, shock and vibration and aging over 15 years, Vc=1.65 Vdc.
- Referenced to Fo @ 25°C. Positive Slope.
- Absolute pull range (APR) is the minimum guaranteed pull range of the VCXO under all conditions over lifetime operation. The APR is referenced to Fo.

DESCRIPTION

The Connor-Winfield VSLD52C1 is a surface mount 3.3V Voltage Controlled Crystal Oscillator (VCXO) with an HCMOS output. Based on a fundamental crystal design the VSLD52C1 is designed for phased lock loop applications requiring low jitter and tight stability.

FEATURES

3.3V OPERATION

TOTAL FREQUENCY TOLERANCE:
±50ppm

INDUSTRIAL TEMPERATURE RANGE:
0 to 70°C

LOW JITTER <1pS RMS

SURFACE MOUNT PACKAGE

TAPE AND REEL PACKAGING

ORDERING INFORMATION

VSLD52C1 - 125.00MHz

VCXO
SERIES

CENTER
FREQUENCY

Specifications subject to change without notice.

CRYSTAL CONTROLLED OSCILLATORS

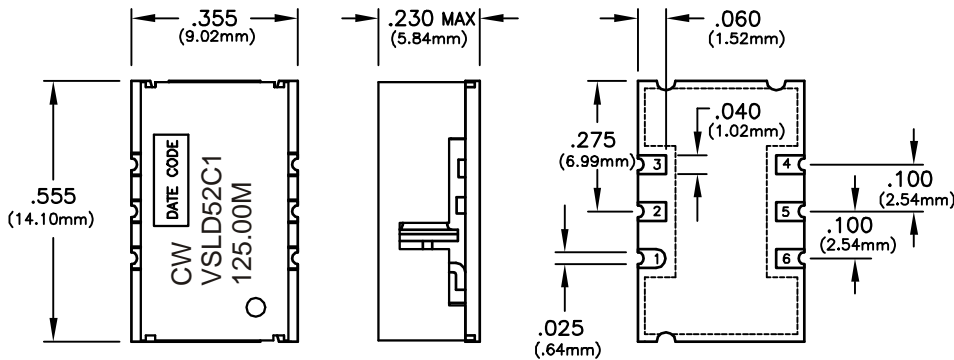

Pad	Connection
1	Control Voltage
2	N/C
3	Ground
4	Output
5	N/C
6	Vcc

Dimensional Tolerance:
±.005" (.127mm)

OUTPUT WAVEFORM

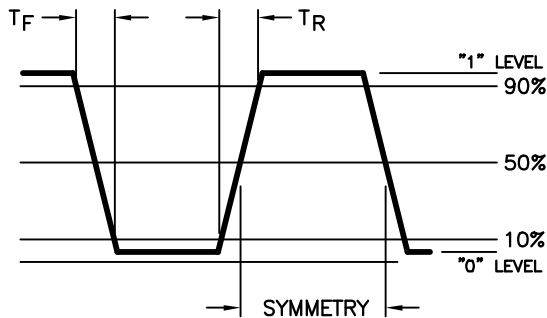

SUGGESTED PAD LAYOUT

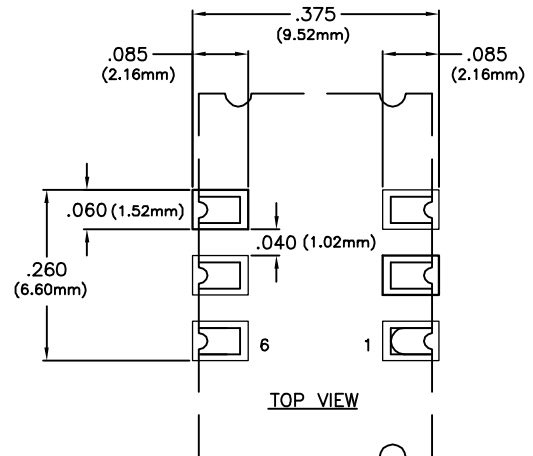

TEST CIRCUIT

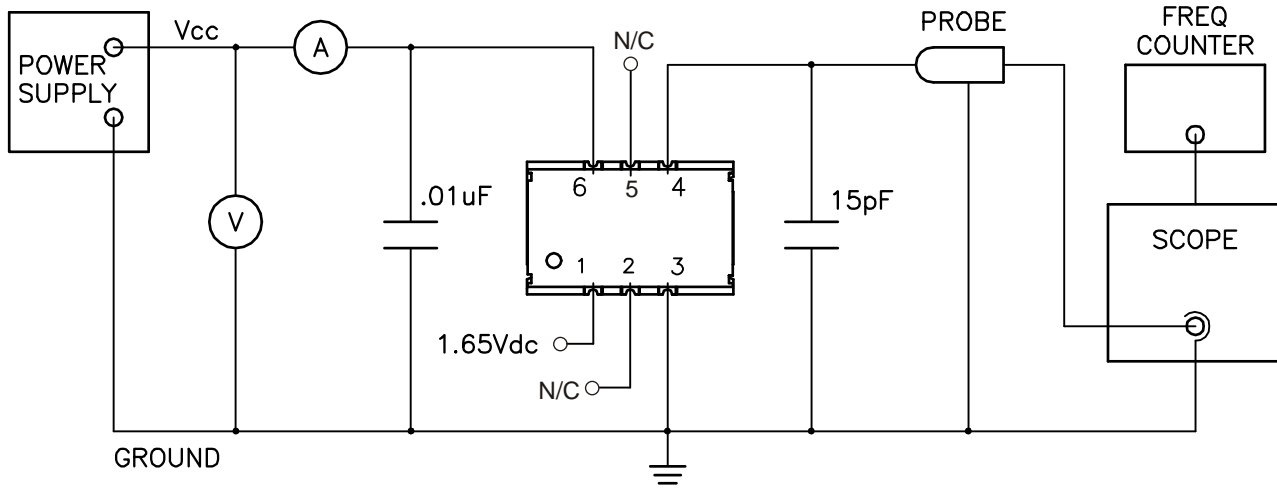

Specifications subject to change without notice.