

SMD Inductors(Coils) For Power Line(Wound, Magnetic Shielded)

Conformity to RoHS Directive

VLCF Series VLCF5020-1

FEATURES

- Miniature size
Mount area: 5×5mm
Height: 2.0mm max.
- Generic use for portable DC to DC converter line
- High magnetic shield construction should actualize high resolution for EMC protection.
- Available for automatic mounting in tape and reel package.
- The products do not contain lead and support lead-free soldering.

APPLICATIONS

DC to DC converters for DVC, DSC, PDA, MD, LCD displays, HDDs, etc.

SHAPES AND DIMENSIONS

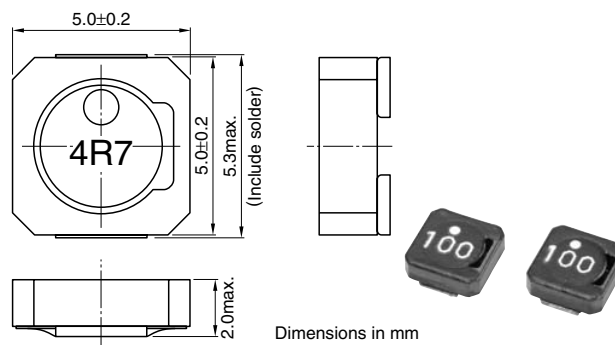

RECOMMENDED PC BOARD PATTERN

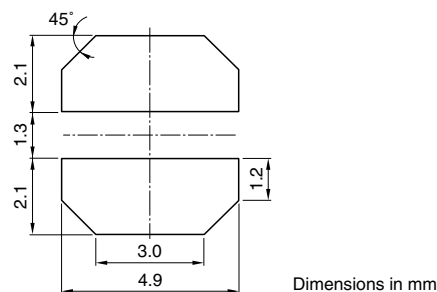

ELECTRICAL CHARACTERISTICS

Part No.	Inductance (μH)	Inductance tolerance	Test frequency (kHz)	DC resistance(Ω)		Rated current(A)*	
				max.	typ.	Based on inductance change max.	Based on temperature rise typ.
VLCF5020T-2R2N2R6-1	2.2	±30%	100	0.071	0.058	2.62	2.76
VLCF5020T-2R7N2R2-1	2.7	±30%	100	0.083	0.069	2.28	2.55
VLCF5020T-3R3N2R0-1	3.3	±30%	100	0.096	0.079	2.02	2.37
VLCF5020T-4R7N1R7-1	4.7	±30%	100	0.122	0.102	1.7	2.09
VLCF5020T-6R8N1R3-1	6.8	±30%	100	0.165	0.138	1.39	1.8
VLCF5020T-100M1R1-1	10	±20%	100	0.237	0.198	1.13	1.5
VLCF5020T-150MR90-1	15	±20%	100	0.35	0.292	0.90	1.2
VLCF5020T-220MR75-1	22	±20%	100	0.496	0.413	0.75	1.0
VLCF5020T-330MR62-1	33	±20%	100	0.717	0.597	0.62	0.86
VLCF5020T-470MR51-1	47	±20%	100	1.05	0.875	0.51	0.71

* Rated current: Value obtained when current flows and the temperature has risen to 40°C or when DC current flows and the nominal value of inductance has fallen by 30%, whichever is smaller.

- Operating temperature range: -40 to +105°C (Including self-temperature rise)

- Conformity to RoHS Directive: This means that, in conformity with EU Directive 2002/95/EC, lead, cadmium, mercury, hexavalent chromium, and specific bromine-based flame retardants, PBB and PBDE, have not been used, except for exempted applications.

- All specifications are subject to change without notice.